

Operating Instructions (ENG)

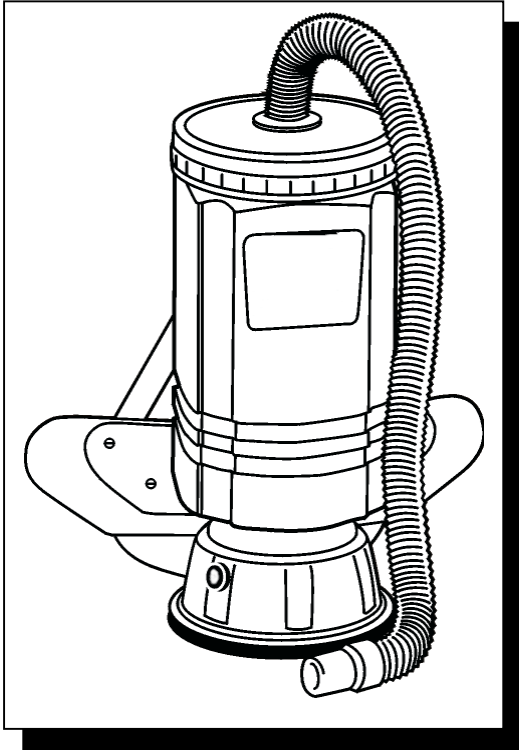

MODELS: VP6, UVP6
VP10, UVP10
VPB10



Read instructions before operating the machine.

MACHINE DATA LOG/OVERVIEW

MODEL _____

DATE OF PURCHASE _____

SERIAL NUMBER _____

YOUR DEALER

Name: _____

Address: _____

Phone Number: _____

TABLE OF CONTENTS

<i>Machine Data Log/Overview</i>	2
<i>Table of Contents</i>	3

HOW TO USE THIS MANUAL

<i>How to use this Manual</i>	1-1
-------------------------------------	-----

SAFETY

<i>Important Safety Instructions</i>	2-1
<i>Hazard Intensity Level</i>	2-2
<i>Grounding instructions</i>	2-3

OPERATIONS

<i>Technical Specifications</i>	3-1
<i>Equipment Set-Up</i>	3-2
<i>Machine Operation</i>	3-2

MAINTENANCE

<i>Daily Maintenance</i>	4-1
<i>Wiring Diagram</i>	4-1
<i>Machine Troubleshooting</i>	4-2
<i>Service Schedule</i>	4-2

PARTS LIST

<i>Assembly Group</i>	5-1
<i>Accessory Tools and Kits</i>	5-3
<i>Suggested Spare Parts</i>	5-4

HOW TO USE THIS MANUAL

This manual contains the following sections:

- HOW TO USE THIS MANUAL
- SAFETY
- OPERATIONS
- MAINTENANCE
- PARTS LIST

The HOW TO USE THIS MANUAL section will tell you how to find important information for ordering correct repair parts.

Parts may be ordered from authorized dealers. When placing an order for parts, the machine model and machine serial number are important. Refer to the MACHINE DATA box which is filled out during the installation of your machine. The MACHINE DATA box is located on the inside of the front cover of this manual.

MODEL _____
DATE OF PURCHASE _____
SERIAL NUMBER _____

The model and serial number of your machine is on the bottom back-end of the machine.

The SAFETY section contains important information regarding hazard or unsafe practices of the machine. Levels of hazards is identified that could result in product or personal injury, or severe injury resulting in death.

The OPERATIONS section is to familiarize the operator with the operation and function of the machine.

The MAINTENANCE section contains preventive maintenance to keep the machine and its components in good working condition.

The PARTS LIST section contains assembled parts illustrations and corresponding parts list. The parts lists include a number of columns of information:

- **REF** – column refers to the reference number on the parts illustration.
- **PART NO.** – column lists the part number for the part.
- **QTY** – column lists the quantity of the part used in that area of the machine.
- **DESCRIPTION** – column is a brief description of the part.
- **SERIAL NO. FROM** – column indicates the first machine the part number is applicable to. When the machine design has changed, this column will indicate serial number of applicable machine. The main illustration shows the most current design of the machine. The boxed illustrations show older designs.
- **NOTES** – column for information not noted by the other columns.

IMPORTANT SAFETY INSTRUCTIONS

When using an electrical appliance, basic precaution must always be followed, including the following:

READ ALL INSTRUCTIONS BEFORE USING THIS MACHINE.



To reduce the risk of fire, electric shock, or injury:

Do not leave the appliance when plugged in. Unplug from outlet when not in use and before servicing.

Do not use outdoors or on wet surfaces.

Do not allow to be used as a toy. Close attention is necessary when used by or near children.

Use only as described in this manual. Use only manufacturer's recommended attachments.

Do not use with damaged cord or plug. If appliance is not working as it should, had been dropped, damaged, left outdoors, or dropped into water, return to an authorized service center.

Do not pull or carry by cord, use cord for handle, close a door on cord, or pull cord around sharp edges or corners. Keep cord away from heated surfaces.

Do not unplug by pulling on cord. To unplug, grasp the plug, not the cord.

Do not put any object into openings. Do not use with any opening blocked; keep free of dust, lint, hair, and anything that may reduce airflow.

Do not operate without dust bag and filter in place.

Keep hair, loose clothing, fingers, and all parts of body away from openings and moving parts.

Turn off all controls before unplugging.

Use extra care when cleaning on stairs.

Do not use to pick up flammable or combustible liquids, such as gasoline, or use in areas where they may be present.

Do not pick up anything that is burning or smoking, such as cigarettes, matches, or hot ashes.

This machine is not suitable for picking up hazardous dust.

Maintenance and repairs must be done by qualified personnel.

Connect to a properly grounded outlet. See grounding instructions.

SAVE THESE INSTRUCTIONS

HAZARD INTENSITY LEVEL

The following symbols are used throughout this guide as indicated in their descriptions:

HAZARD INTENSITY LEVEL

There are three levels of hazard intensity identified by signal words -**WARNING** and **CAUTION** and **FOR SAFETY**. The level of hazard intensity is determined by the following definitions:

! WARNING

WARNING - Hazards or unsafe practices which COULD result in severe personal injury or death.

! CAUTION

CAUTION - Hazards or unsafe practices which could result in minor personal injury or product or property damage.

FOR SAFETY: To Identify actions which must be followed for safe operation of equipment.

Report machine damage or faulty operation immediately. Do not use the machine if it is not in proper operating condition. Following is information that signals some potentially dangerous conditions to the operator or the equipment. Read this information carefully. Know when these conditions can exist. Locate all safety devices on the machine. Please take the necessary steps to train the machine operating personnel.

FOR SAFETY:

DO NOT OPERATE MACHINE:

Unless Trained and Authorized.

Unless Operation Guide is Read and understood.

In Flammable or Explosive areas.

In areas with possible falling objects.

WHEN SERVICING MACHINE:

Avoid moving parts. Do not wear loose clothing; jackets, shirts, or sleeves when working on the machine. Use manufacturer approved replacement parts.

GROUNDING INSTRUCTIONS

THIS PRODUCT IS FOR COMMERCIAL USE ONLY.

ELECTRICAL:

In the USA this machine operates on a standard 15 amp 115V, 60 hz, A.C. power circuit. The amp, hertz, and voltage are listed on the data label found on each machine. Using voltages above or below those indicated on the data label will cause serious damage to the motors.

EXTENSION CORDS:

A suitable extension cord is provided with this appliance. The safe operation of the appliance is dependent on the use of a suitable extension cord. If a cord other than the one provided is used, it must be type SJT, at least 16 gauge, and limited to no more than 50 feet in length.

GROUNDING INSTRUCTIONS:

This appliance must be grounded. If it should malfunction or break down, grounding provides a path of least resistance for electric current to reduce the risk of electric shock. This appliance is equipped with a cord having an equipment-grounding conductor and grounding plug. The plug must be inserted into an appropriate outlet that is properly installed and grounded in accordance with all local codes and ordinances.

This appliance is for use on a nominal 120-volt circuit, and has a grounded plug that looks like the plug in "Fig. A". A temporary adaptor that looks like the adaptor in "Fig. C" may be used to connect this plug to a 2-pole receptacle as shown in "Fig. B", if a properly grounded outlet is not available. The temporary adaptor should be used only until a properly grounded outlet (Fig. A) can be installed by a qualified electrician. The green colored rigid ear, lug, or the like extending from the adaptor must be connected to a permanent ground such as a properly grounded outlet box cover. Whenever the adaptor is used, it must be held in place by a metal screw.

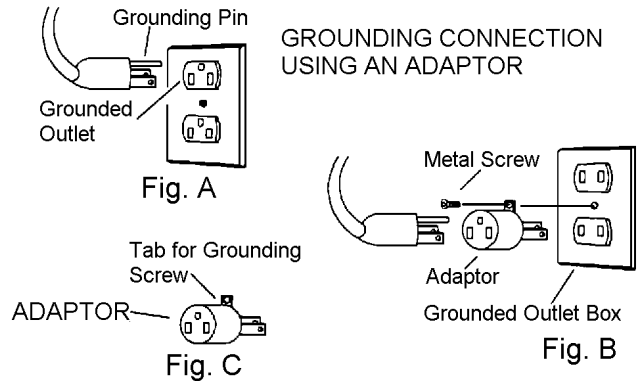

Note: Adaptors are not allowed in Canada.

! WARNING

Improper connection of the equipment-grounding conductor can result in a risk of electric shock. Check with a qualified electrician or service person if you are in doubt as to whether the outlet is properly grounded. Do not modify the plug provided with the appliance - if it will not fit the outlet, have a proper outlet installed by a qualified electrician.

TECHNICAL SPECIFICATIONS

ITEM	DIMENSION/CAPACITY
POWER TYPE:	
ELECTRICAL:	115V, 8A, 60 Hz
ELECTRIC VACUUM MOTOR:	SINGLE STAGE, 1.6 HP, 80 CFM, (2.2 CUBIC METERS/MIN.)
WATERLIFT:	95 INCHES OF WATER
FILTER BAG:	VP6/UVP6-6 QUART VP10/UVP10/VPB10-10 QUART
GENERAL DIMENSIONS/WEIGHT	
VACUUM HOSE:	5' (1.5M) X 1.5" (3.8CM) DIAMETER
WEIGHT:	VP6/UVP6 10.1 LB. (4.6 KG) VP10/UVP10/VPB10 11.0 LB. (5.0 KG)
DEPTH:	10.5" 267MM
HEIGHT:	VP6/UVP6-19.8" 503MM VP10/UVP10/VPB10-23.7" 602MM
WIDTH:	8.8" 224MM
POWER CABLE:	50' (15.2M) (16 GAUGE)

MACHINE OPERATION

EQUIPMENT SET-UP

1. Insert hose (swivel cuff end) into top of unit. Attach desired cleaning tool.
2. Adjust straps to a loose fit. Place the unit on back and tighten straps until comfortable.

The straps are easily adjusted while the unit is being worn.

To loosen lift up on tab.

To tighten pull on strap.

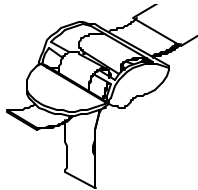

3. Plug power cord from machine into properly grounded wall outlet (see grounding instructions).

OPERATION

The unit is a commercial vacuum designed for dry pick-up only.

1. Place a paper bag inside the cloth bag in the vacuum chamber. Be sure the foam filter is in place at the bottom of the chamber.
2. Attach the accessories to be used.
3. Put unit on back and adjust straps.
4. Plug unit into properly grounded wall outlet (see grounding instructions).
5. Turn machine on or off using switch on left side of machine.
6. To empty, remove the cover and dump paper bag into trash receptacle. Shake cloth bag vigorously each time paper bag is emptied to prevent soil build-up, which would clog filter.

MAINTENANCE & WIRING DIAGRAM

DAILY MAINTENANCE

(At the end of each working day)

1. Turn cloth filter bag inside out and brush clean. Do not use a wire brush. Cloth bags can be vacuumed with another machine or washed occasionally in warm water using a mild, water-based soap without harming filtering capacity. Allow to dry completely before using.
2. Wipe down exterior of machine.
3. Check round foam filter at bottom of vac chamber and clean if necessary.
4. Inspect hose for wear. Frayed or cracked hoses should be replaced to avoid vacuum loss.
5. Inspect power cord for wear. To prevent electric shock, immediately replace cords with frayed or cracked insulation.

WIRING DIAGRAM

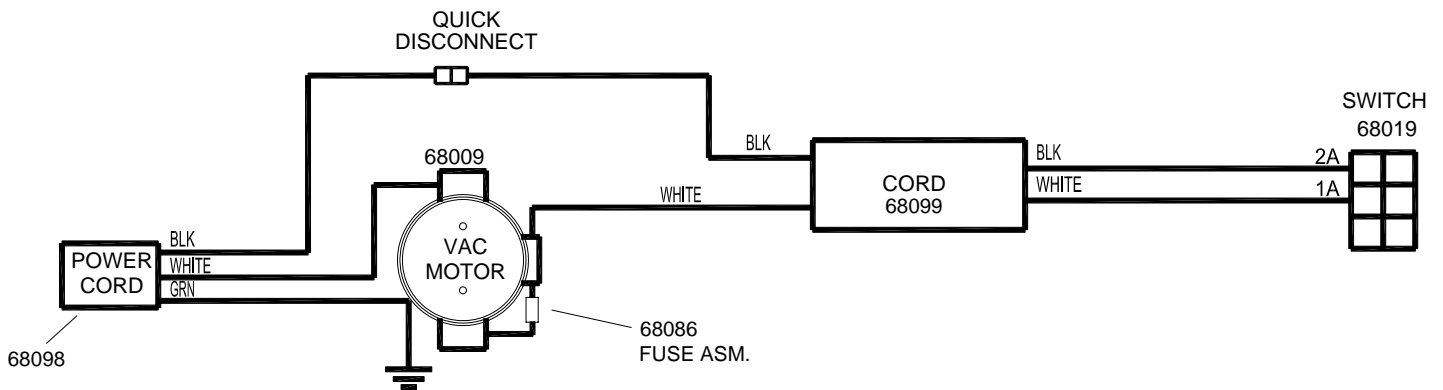

TROUBLESHOOTING

PROBLEM.	CAUSE	SOLUTION
No power, vacuum motor will not run	Is the cord plugged in?	Plug in cord.
	Circuit breaker tripped in building.	Reset breaker.
	Thermal protector tripped	Motor will restart after cooling down. To prevent repeated tripping, clear all restrictions out of hose and tools, replace paper filter bag. Clean cloth filter bag and internal foam filter, clear all restrictions to the exhaust air flow.
	Faulty switch.	Call for service.
Poor vacuum performance	Faulty power cord.	Call for service.
	Debris plugging hose, wand or accessory tool.	Remove debris.
	Paper bag full.	Replace bag.
	Cloth bag plugged.	Remove from machine, turn inside out and shake or brush clean.
	Hosecuffs loose or hose cracked.	Tighten cuffs or replace hose.
	Cap loose on top of machine.	Tighten cap.

SERVICE SCHEDULE

MAINTENANCE	DAILY	WEEKLY	MONTHLY	QUARTERLY
Check bag and replace if necessary	*			
Check hoses for wear, blockages, or damage	*			
Check major gaskets for leakage	*			
Check brush-should be clean with no lint or strings attached	*			
Wind cord and store in upright position	*			
Check hoses for cracks or holes		*		
Check all cords and handles for damage or cracks; replace as necessary		*		
Inspect and replace all filters including exhaust, intake, and microfilters			*	
Check all gaskets for wear and leakage			*	
Check vac motor carbon brushes				*
Check for arcing and pitting on any electrical contacts; replace if found				*
Inspect and clean vac shoe; check for dents and damage which would detrimentally effect vacuum and brush movement				*
Check overall performance of machine				*

VACPAC ASSEMBLY GROUP PARTS

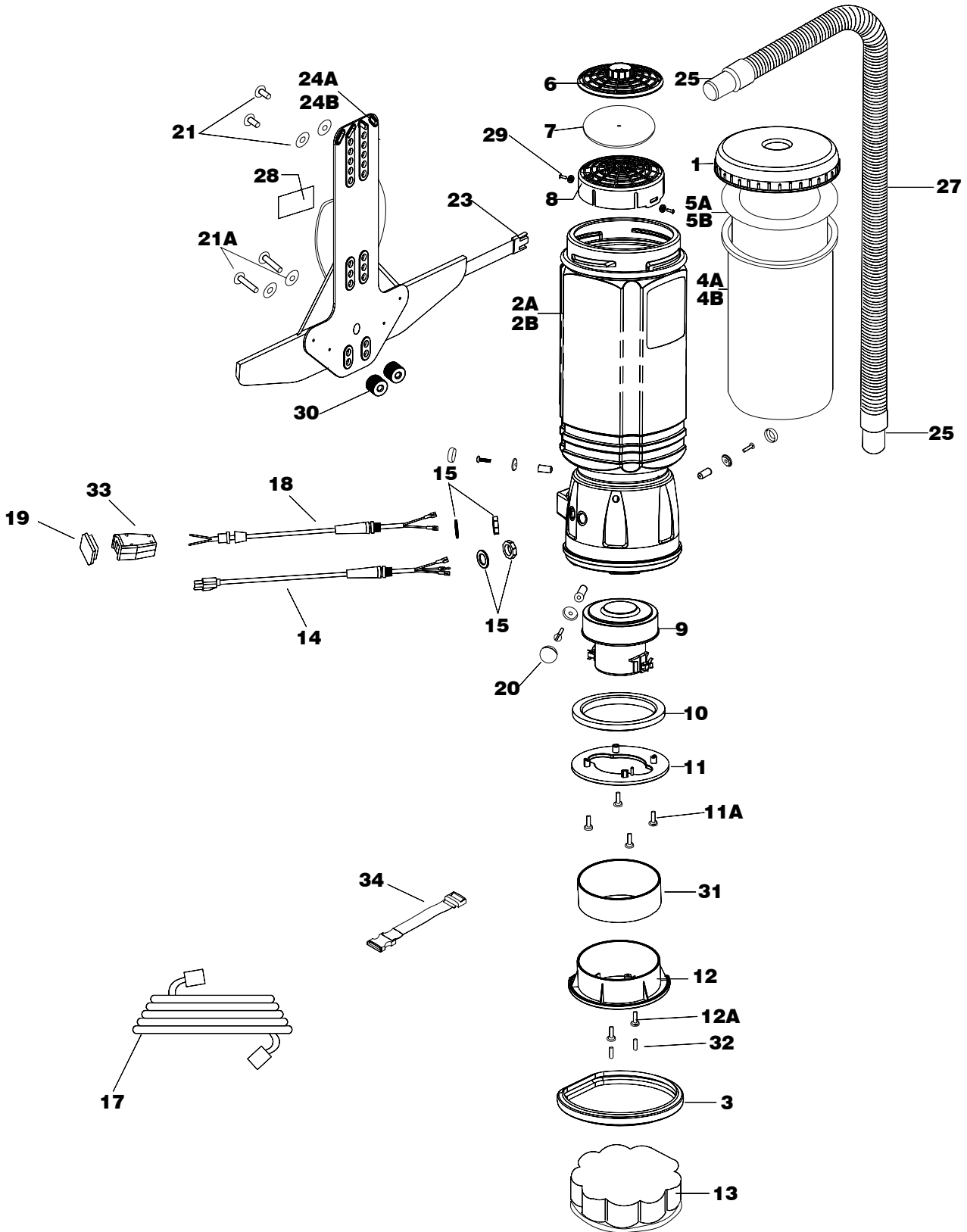

VACPAC ASSEMBLY PARTS LIST

REF	PART NO.	QTY	DESCRIPTION	SERIAL NO. FROM	NOTES:
1	68000BLK	1	CAP, BLACK		
2A	68001	1	TANK, SMALL		
2B	68002	1	TANK, LARGE		
3	68003	1	BUMPER		
4A	68004	1	FILTER BAG, MICRO-TEX (CLOTH) LG		
4B	68074	1	FILTER BAG, MICRO-TEX (CLOTH) SM		
5A	68005	1	FILTER BAG, MICRO (PAPER) LG 10/PKG		
5B	68075	1	FILTER BAG, MICRO (PAPER) SM 10/PKG		
6	68006	1	COVER, FILTER HOUSING		
7	68007	1	FILTER, DOME		
8	68008	1	HOUSING, FILTER		
9	68009	1	MOTOR, VACUUM 115V		
10	68010	1	SEAL, MOTOR		
11	68011	1	RING, MTR COMP W/ SCRS		
11A	68076	1	SCR, MTR COMP RING (4/PKG)		
12	68012	1	DIFFUSER, AIR W/ SCREWS		
12A	68077	1	SCR, AIR DIFFUSER (2/PKG)		
13	68013	1	FILTER, AIR/SOUND DIFFUSER		
14	68098	1	CORD ASM, W/ STRAIN RELIEF	10017669	*
15	68015	2	NUT, STRAIN RELIEF W/ WASHER		
16	OPEN	-	-		
17	68017	1	CORD ASM, 50' EXTENSION		
18	68099	1	CORD ASM, SWITCH W/MOLDED SR	10017669	*
19	68019	1	SWITCH		
20	68020	3	FASTENER SET, MOTOR MOUNT		
21	68030	1	FASTENER SET, BACK PLATE (TOP)		
21A	68081	1	FASTENER SET, BACK PLATE (BTM)		
22	OPEN	-	-		
22A	OPEN	-	-		
23	68054	1	LATCH, WAIST BELT		
24A	68057	1	STRAP ASM, COMPLETE (LG)		
24B	68058	1	STRAP ASM, COMPLETE (SM)		
25	68064	2	CUFF, HOSE SWIVEL		
26	OPEN	-	-		
27	68066	1	HOSE ASSEMBLY		
28	68070	1	LABEL, WARNING		
29	68082	2	FASTENER SET, FILTER HOUSING		
30	68083	2	SPACER, BACK PLATE		
31	68092	1	FOAM, DIFFUSER		
32	68093	2	PLUG, DIFFUSER		
33	72177	1	SWITCH BOX W/ SCREWS		
34	68096	1	STRAP, WAIST EXTENSION VP		

* PRIOR TO SERIAL #10017669, ORDER #47391

ACCESSORY TOOLS AND KITS

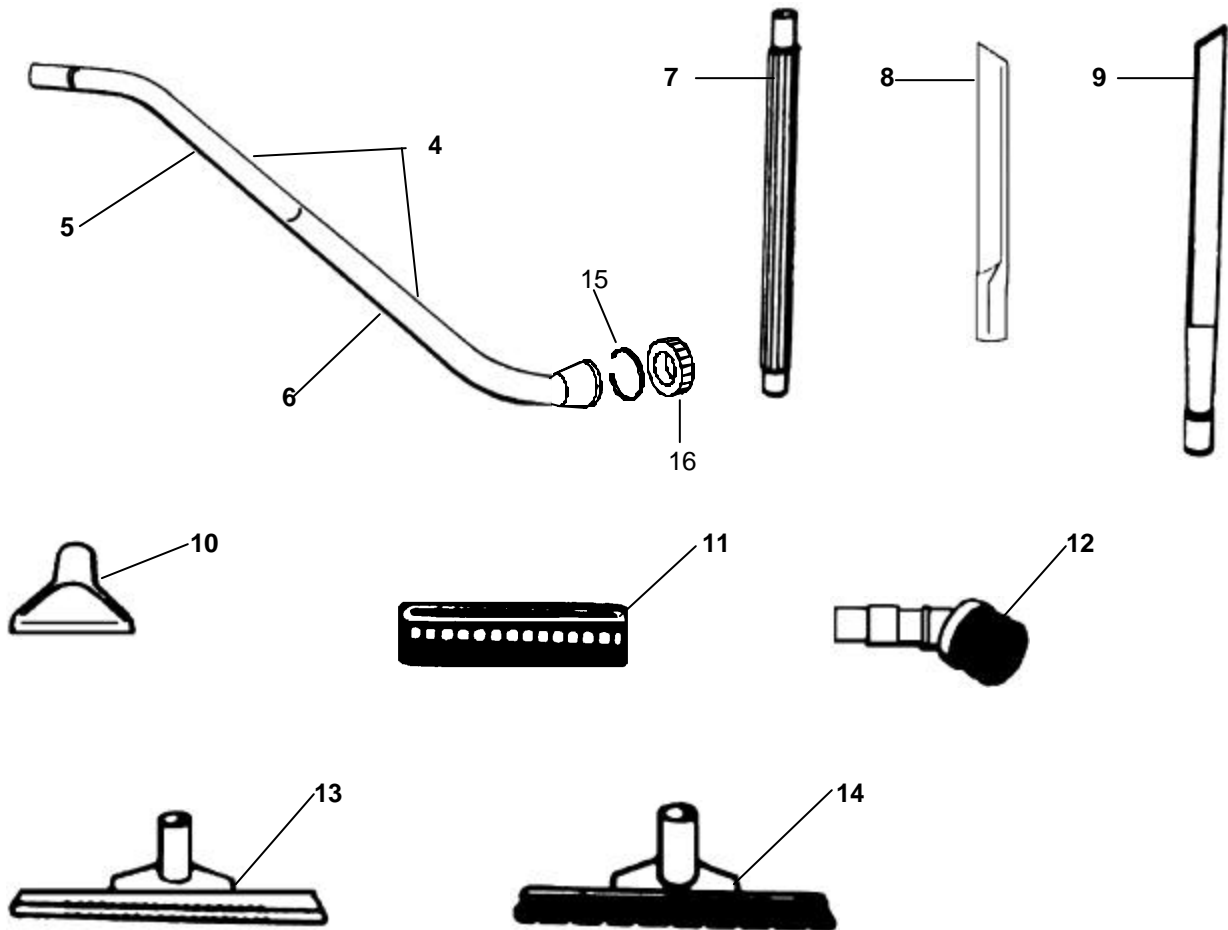
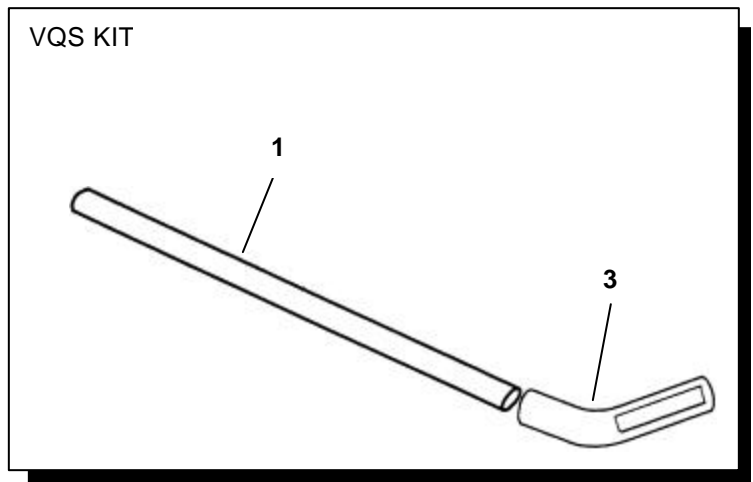
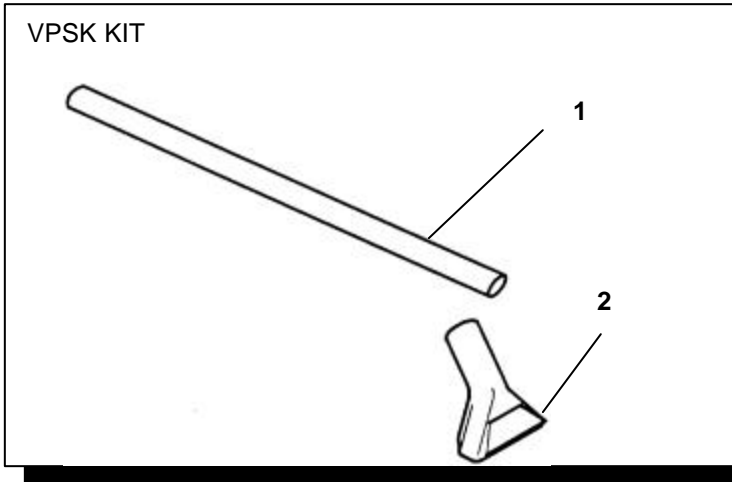

ACCESSORY TOOLS PARTS LIST

REF	PART NO.	QTY	DESCRIPTION	SERIAL NO. FROM	NOTES:
1	89079	1	WAND, SPOTTER		VPSK, VQS
2	78263	1	TOOL, SPOT LITE		VPSK
3	78277	1	TOOL, QUICK SWEEP		VQS
4	02443	1	WAND, DOUBLE CURVE 2 PC. ALUM.		INCL 5, 6, 15 & 16
5	68062	1	WAND, UPPER		
6	68078	1	WAND, LOWER		INCL 15 & 16
7	02086	1	TUBE, 20" EXTENSION		
8	68068	1	TOOL, 16" CREVICE		
9	02293	1	TOOL, 28" PLASTIC CREVICE		
10	02084	1	TOOL, 5" UPHOLSTERY		
11	02085	1	BRUSH, UPHOLSTERY		
12	02083	1	BRUSH, 3" DUST		
13	02004	1	TOOL, CARPET		
14	02003	1	TOOL, BRISTLE SHOD DRY PICK-UP		
15	68094	1	RING, BOTTOM WAND		
16	68090	1	NUT, BOTTOM WAND		

SUGGESTED SPARE PARTS

PART NO.	DESCRIPTION	NOTES:
68004	FILTER BAG, MICRO-TEX (CLOTH) LG	
68074	FILTER BAG, MICRO-TEX (CLOTH) SM	
68005	FILTER BAG, MICRO (PAPER) LG 10/PKG	
68075	FILTER BAG, MICRO (PAPER) SM 10/PKG	
68007	FILTER, DOME	
68013	FILTER, AIR/SOUND DIFFUSER	
68086	FUSE ASM	
68097	BRUSH SET (PKG 2)	