

Clarke®

Operator's Manual

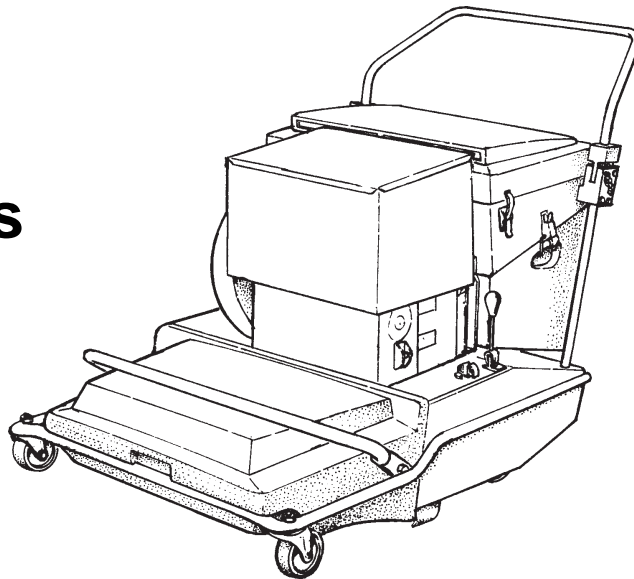

Model SPS-28

READ THIS BOOK

This book has important information for the use and safe operation of this machine. Failure to read this book prior to operating or attempting any service or maintenance procedure to your Clarke machine could result in injury to you or to other personnel; damage to the machine or to other property could occur as well. You must have training in the operation of this machine before using it. If your operator(s) cannot read this manual, have it explained fully before attempting to operate this machine.

Si Ud. o sus operadores no pueden leer el Inglés, se hagan explicar este manual completamente antes de tratar el manejo o servicio de esta máquina.

All directions given in this book are as seen from the operator's position at the rear of the machine.

For new books write to: Clarke®, 2100 Highway 265, Springdale, Arkansas 72764.

Table of Contents

Operator Safety Instructions	3
Operator Safety Instructions Battery Powered Machine	4
Introduction & Machine Specifications	5
How to Prepare the Machine for Operation 28G	6
How to Check the Oil	6
How to Fill the Gasoline Tank	6
How to Prepare the Machine for Operation 28B	7
How to Charge the Batteries	7
How to Operate the Machine	8
How to Operate the Sweeper	8
How to Operate the Side Broom	9
Sweeping	9
How to Empty the Debris Hopper	10
How to Clean Filters	10
Parts and Service Manual - Section II	
Maintenance Procedures	12
How to Check the Engine	12
How to Clean the engine Air Filter	12
How to Lubricate	12
How to Adjust the Main Broom	13
How to Adjust the Side Broom Belt	13
How to Adjust the Friction Drive Wheel	13
How to Adjust the Engine Speed (28G)	13
How to Stall a New Main Brush	13
Service Hints	14
Capacitor Tests	15
Diode Test	15
Assembly drawing for Main Frame, Brush and Drive system	16
Parts List	17
Assembly drawing for Engine, Dust Control and Handle	18
Parts List	19
Assembly drawing for Hopper and Optional Sidebroom Assembly	20
Parts List	21
Assembly drawing for Battery Powered Model SPS-28B	22
Parts List	22
Wiring Diagram	24
Parts List	25
Schematic Diagram	26

OPERATOR SAFETY INSTRUCTIONS



WARNING



AVERTISSEMENT



ADVERTENCIA

DANGER means:	Severe bodily injury or death can occur to you or other personnel if the DANGER statements found on your machine or in your Owner's Manual are ignored or are not adhered to. Read and observe all DANGER statements found in your Owner's Manual and on your machine.
WARNING means:	Injury can occur to you and to other personnel if the WARNING statements found on your machine or in your Owner's Manual are ignored or are not adhered to. Read and observe all WARNING statements found in your Owner's Manual and on your machine.
CAUTION means:	Damage can occur to the machine or to other property if the CAUTION statements found on your machine or in your Owner's Manual are ignored or are not adhered to. Read and observe all CAUTION statements found in your Owner's Manual and on your machine.



DANGER:

Failure to read the Operator's Manual prior to using this machine could result in injury to you or to other personnel; damage to the machine or to other property could occur as well. You must have training in the operation of this machine before using it. If you or your operator(s) cannot read English, have this manual explained fully before attempting to operate this machine



DANGER:

Machines can cause an explosion when operated near flammable materials and vapors. Do not use this machine with or near fuels, grain dust, solvents, thinners, or other flammable materials.



DANGER:

Operating a machine that is not completely or fully assembled could result in injury or property damage. Do not operate this machine until it is completely assembled.



DANGER:

Filling a machine with fuel in an explosive or poorly-ventilated area can cause an explosion. Only fill the fuel tank in an open area. Do not fill the tank near open flames or while the machine is running. Do not smoke while filling the tank. Do not over-fill the tank. Wipe up any spills. Tighten the cap on the tank when finished.



DANGER:

Always leave the machine on a level surface. The machine could roll and cause injury to the operator or property damage. **When you stop the machine, always put the throttle lever to stop position until the engine stops.**



WARNING:

Failure to read and observe all safety statements found on your machine or in this Operator's Manual can result in serious injury or damage. Read and observe all safety statements. Make sure that all labels, decals, warnings, cautions, and instructions are fastened to the machine. Get new labels from your authorized Clarke distributor.



WARNING:

To avoid inhaling exhaust fumes, operate machine in a well ventilated area only. Engine exhaust fumes are dangerous to your health.



CAUTION:







Maintenance and repairs performed by unauthorized personnel could result in damage or injury. Maintenance and repairs performed by unauthorized personnel will void your warranty. Servicing of this unit must always be referred to an authorized Clarke distributor.



CAUTION:

Use of this machine to move other objects or to climb on could result in injury or damage. Do not use this machine as a step or furniture. Do not ride on this machine.

Operator Safety Instructions for Battery Powered Machine

-  **CAUTION:** Connect or disconnect the battery plug only when the charger supply cord is disconnected or arcing and burning may result.
-  **CAUTION:** Do not expose to rain. Replace defective cords immediately. If the charger is dropped or otherwise damaged, inspect it thoroughly.
-  **CAUTION:** Provide adequate ventilation while charging. Improper ventilation could cause fumes or gases to injure the operator or others.
-  **CAUTION:** Never work on the charger with cords connected to the AC supply or to the batteries.
-  **WARNING:** Leave the machine only on a level surface to avoid injury. When you stop the machine, always put the switch in the "OFF" position.
-  **WARNING:** Batteries must be installed and serviced by authorized personnel only. Always wear eye protection and protective clothing when working near batteries. **NO SMOKING!**
-  **WARNING:** Lead acid batteries generate gases which can cause an explosion! Keep sparks and flames away from batteries. Do not put tools or other metal objects across the battery terminals or the top of the batteries.
- NOTE:** For best results, charge the batteries after each use.

INTRODUCTION

The Model SPS-28 will effectively and efficiently sweep your floors at minimum cost, provided you operate this machine with reasonable care and maintain it in accordance with the instructions contained in this operator's manual.

SPECIFICATIONS

Gasoline Engine (Model 28G):	5 HP (2.98 kw) Briggs and Stratton (2,150 R.P.M. factory set)
Electric Motor: (Model 28B): Batteries:	¾ HP (56 kw) D.C. permanent magnet Two 12-volt in 24 volt system (95 amp hours -SAE 6 hr. rate)
Charger:	24-volt
Forward Speed:	Variable up to 250 ft./min. (76.2 m/min.) (35,000 sq. ft. (3252 m ²)m per hour
Front Hopper:	1.5 cu. ft. (.4m ³) capacity
Rear Hopper:	1.8 cu. ft. (.5m ³) capacity
Wheel:	One 8 inch (20.3 cm) diameter swivel, sealed bearings
Casters:	Two 4 inch (10.2 cm) diameter swivel, sealed bearings
Main Broom:	10 inch (25.4 cm) diameter x 28 inch (71.1 cm) long Polypropylene bristles. Brush height adjustable. Optional brush for sweeping carpets - Union mix bristles
Broom Speed:	300 RPM
Sweeping Swath:	28 inch (71.1 cm.), 36 inch (91.4 cm.) with optional side broom
Filter:	Standard (dry paper) panel type with 34.34 sq. ft. (5.98 cm ²) filtering area. Optional accordion type filter with 55.23 sq. ft. (5.13 cm ²) filter area
Dimensions:	56 L x 33 H x 37½ W over handle 142.2 cm x 83.8 cm x 95.3 cm
Weight - Gasoline Battery	209 lbs. (94.8 kg) 339 lbs. (153.8 kg)

How to Prepare The Machine for Operation

Model 28G (Gasoline Powered)

NOTE: Do not attempt to operate the CLARKE Model SPS-28 before reading the instructions in this manual.

 **WARNING:** To prevent injury , always wear protective clothing. Do not wear loose clothing.

Before starting the MODEL SPS -28G follow these instructions:

HOW TO CHECK THE OIL

 **WARNING:** Do not check the engine oil level when the engine is running. Failure to check the oil level before you use the machine can destroy the engine. Always make sure the machine has the correct amount of oil.

Follow this procedure to check the oil:

1. Make sure the machine is on level ground.
2. Turn the cap marked "Engine Oil" counterclockwise.
3. Lift the dipstick out of the tube.
4. If the mark is below "OK", add oil.
5. When adding oil, make sure the oil does not pass the mark "FULL" on the dipstick.

See the engine manual for the correct type of oil.

HOW TO FILL THE GASOLINE TANK

 **WARNING:** Fill the gasoline tank in an open area. Do not fill the tank near open flames. Do not fill the gasoline tank while the engine is running. Gasoline is very flammable and creates vapors. Serious injury to the operator or others could occur.

 **WARNING:** Gasoline is very flammable. When filling the gasoline tank, make sure the gasoline only reaches the bottom of the filter neck of the fuel tank.. Make sure you do not spill any gasoline. Use a cloth to remove spilled gas.

 **WARNING:** Do not mix oil with the gasoline. Damage to the engine could occur.

Fill the gasoline tank only with regular unleaded gasoline. Use a clean container. Prevent dirt and debris from falling into the tank. Always tighten the cap on the tank.

How to Prepare The Machine for Operation

Model SPS-28B - Battery Powered

1. Before starting the SPS-28B lift the battery box cover and make sure the battery cables are connected.
2. Place all controls in "NEUTRAL".
3. Turn OFF/ON switch to "ON" position. (Switch is located on left side, below hourmeter.

NOTE: The OFF/ON switch is also a circuit breaker which senses overload on the drive motor and breaks the circuit. Should this occur, determine the cause of the overload (e.g., remove the debris jamming the main broom) and turn the circuit breaker back to the "ON" position.

HOW TO CHARGE THE BATTERIES

Put the charger on a flat surface. Make sure the vents on the sides of the charger are at least two inches away from the walls and other objects. Make sure there are no objects near the bottom vents of the charger.

To charge the batteries, follow this procedure:

1. Turn the machine OFF.
2. Connect the DC connector on the charger to the connecting plug on the batteries. See Fig. 1
3. Connect the AC plug on the charger to a receptacle that has the correct voltage and frequency for your charger. Make sure the receptacle is connected to the electrical ground.
4. The electronic timer stops the charger when the batteries are fully charged.

See the instruction book for the charger, and for more instructions on how to use the charger and charge the batteries.

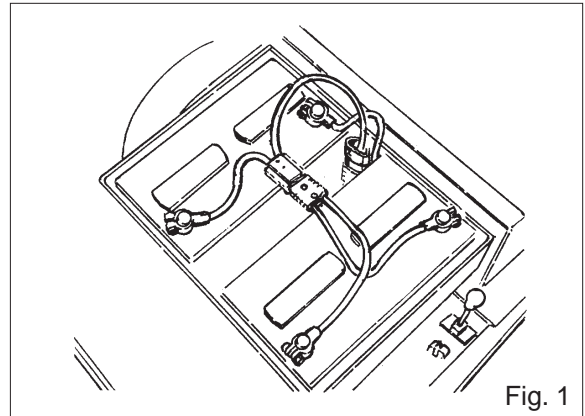

HOW TO OPERATE THE MACHINE

NOTE: Do not attempt to operate the CLARKE Model SPS-28 before reading the instructions in this manual.

⚠ WARNING: To prevent injury , always wear protective clothing. Do not wear loose clothing.

⚠ WARNING: Do not check the engine oil level when the engine is running. Failure to check the oil level before you use the machine can destroy the engine. Always make sure the machine has the correct amount of oil.

Follow the procedures below when operating the machine:

1. Turn the timer-switch to the "OFF" position.
2. Insert the DC charger plug into the unkeyed battery bank plug.
3. Plug the AC cord into a single phase grounded outlet with voltage and frequency corresponding to the charger nameplate. Assure that the circuit has adequate capacity to handle the nameplate current.
4. Turn the timer-switch clockwise directly to the "ON" position. The AC pilot light and the DC ammeter show that the charger is on and charging. The charger will run for a total period of sixteen (16) hours; the timer-switch knob will rotate clockwise and automatically turn the charger off when the pointer reaches the "OFF" position.
5. The charger may remain connected to the batteries for extended periods without harming the charger or discharging the batteries.

How to Operate the Sweeper

1. Adjust the main broom to correct sweeping* by rotating broom adjusting lever - clockwise to raise, counterclockwise to lower. (See Fig. 2)
2. Lower the main broom to "SWEEP" setting by placing the adjusting lever in the horizontal latched position.

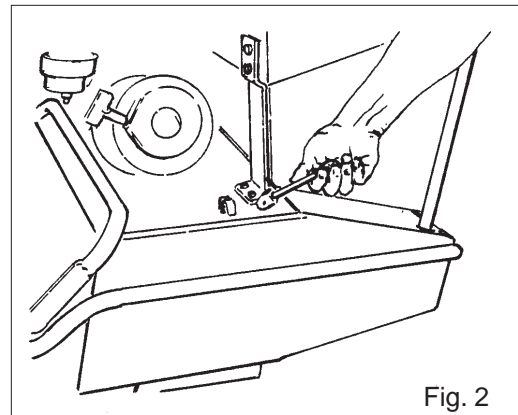

Fig. 2

HOW TO OPERATE THE MACHINE (cont)

How to Operate the Side Broom (Optional):

1. Engage the side broom in "SWEEP" position by grasping the head assembly, pulling forward and rotating downward until the pin in the arm assembly is against the stop on the locating collar. Turn off engine or motor when adjusting side broom.
2. When adjusting the side broom, the most effective setting for the side broom is generally having about one-third of the bristles engaged with the floor in "SWEEP" position.
3. To change the angle of the broom, to the floor, loosen the knob and rotate the head assembly until the desired angle is obtained.

To change the height of the side broom, i.e., (1) lower or more bristle contact; (2) higher or less bristle contact, follow these instructions:

1. Lower the broom assembly to its engaged position and be certain the locking pin is in its slot on the collar.
2. Loosen the two socket head screws which lock the split collar to the tubular bumper.
3. Swivel the collar until the correct height is obtained. Hold in this position, maintaining tension on the side broom belt, and tighten the two screws to lock the collar.

Sweeping

Stand behind the machine and push the control handle down to activate the clutch, which supplies forward motion.

Turning the sweeper will be easier if down pressure is released on the control handle just before starting to make a turn.

To stop the machine, release the down pressure on the control handle.

To stop the engine (Model 28G) turn stop switch OFF.

To stop motor (Model 28B), turn OFF/ON switch to "OFF" position.

HOW TO OPERATE THE MACHINE (cont)

How to Empty Debris Hopper:

⚠ WARNING: To prevent injury, always stop the engine or motor before you empty the hoppers or clean the filter.

1. Grasp the hopper by the handle provided and lift out until clear of frame.
2. Dump debris in appropriate location and replace hopper in machine. (See Fig. #3)
3. Release the two (2) retaining latches on either side of the hopper.
4. Slide the hopper out (toward the rear) from under the filter compartment.
5. Dump dust and debris in appropriate location and replace hopper in machine.
6. Snap retaining latches to hold hopper. (See Fig. 4)

Cartridge (Panel) Filter

To insure continued maximum efficiency of the dust control system on your sweeper, the cartridge filter should be removed and cleaned often. The frequency of this cleaning is related to the sweeping application; i.e., the dustier the area is, the more frequently the filter should be cleaned.

Cleaning Panel Filter

Remove from machine and tap gently on flat surface, dirty side down. (See Fig. 5)

OR

Use compressed air (100 psi maximum), directing it through the panel **opposite** the direction of the arrows.

OR

Soak for fifteen minutes in water and a low-foaming, mild detergent. Rinse with water until clean (maximum 40 psi).

Air Dry - Do not use compressed air.

Accordion Type Cloth Filter (Optional)

To insure continued maximum efficiency of the dust control system on your sweeper, the cloth type filter should be frequently shaken (See Fig. 6) using the handles provided. The dustier an area is, the more often the shakedown should be done. The dust hopper should then be emptied.

How to Clean the Cloth Filter

Remove filter assembly from the machine. Direct compressed air through material **opposite** the normal air flow direction. (See Fig. 7)

OR

Wash with a mild low-foaming detergent and water. Let dry thoroughly before putting back into service.

NOTE: This filter is treated with a flame retardant chemical. The washing method of cleaning neutralizes and/or eliminates this resistance to burning.

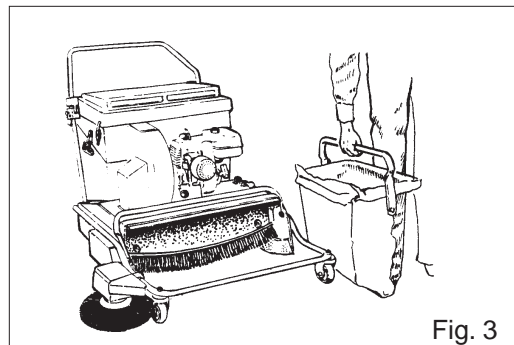

Fig. 3

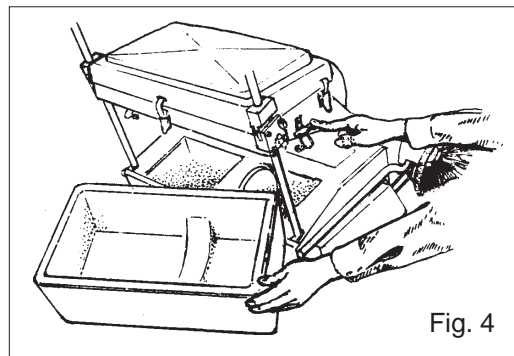

Fig. 4

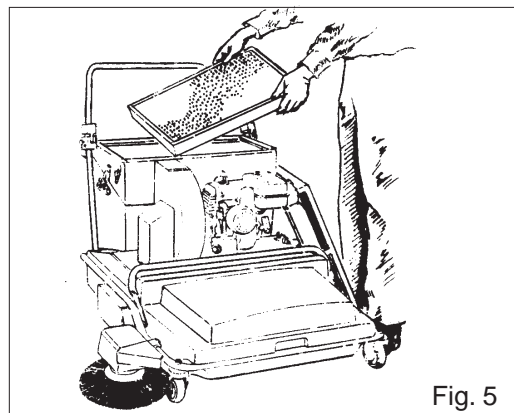

Fig. 5

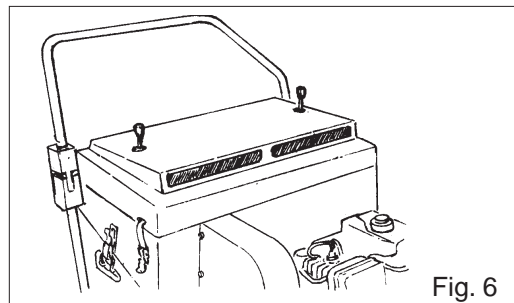

Fig. 6

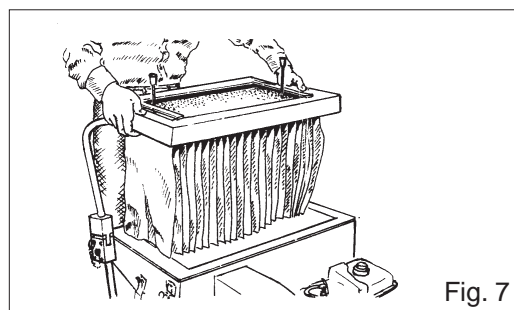

Fig. 7

Clarke[®]
SPS-28
Space Sweeper
(INCLUDES 28G & 28B)
Section II
Parts and Service Manual

(70466A)

SERVICE AND MAINTENANCE

⚠ WARNING: Maintenance and repairs must be done by authorized personnel only. Keep Adjustments according to specifications.

⚠ WARNING: To prevent injury always stop the engine or motor before doing any maintenance or repairs to this machine. Separate the connectors between the machine and batteries. Disconnect the wire from the spark plug.

How To Check the Engine

1. Check oil level regularly. Change oil after using first two tanks of gasoline. change oil regularly after each twenty-five (25) operating hours, or more often in extremely dirty conditions.
2. Keep the engine clean and remove dirt and oil from coiling fins, screen and flywheel for best engine performance and to prevent damage from overheating.

Do not allow dirt to enter the engine when checking oil or adding fuel.

Wire brush carbon deposits from spark plug electrodes and regap at .030 in.

How to Clean the Engine Air Filter

Clean and re-oil every ten (10) hours - more often under extremely dusty conditions.

1. Remove filter element. Separate pre-filter from pleated filter.
2. Clean pre-filter only in detergent and warm water.
3. Squeeze dry.
4. Apply liberal amount of clean engine oil and distribute evenly. Squeeze out excess oil.
5. Install element.

Lubrication

The Model SPS-28 has one grease fitting on the main drive wheel. Apply two strokes of lubricant (PN 883853) from a grease gun each month. (See Fig. 8)

⚠ WARNING: To prevent injury and damage, remove the batteries or gasoline before tipping the machine.

To get access to the grease fitting, remove the batteries and hoppers and tip the machine on its side.

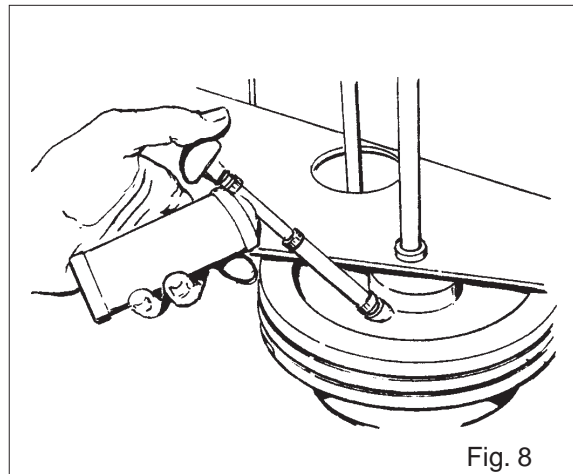

Fig. 8

Drive Belts

⚠ WARNING: To prevent injury always stop the engine or motor before doing any maintenance or repairs to this machine.

The drive belts are automatically tensioned by a spring-loaded idler wheel. (See Fig. 9)

1. Remove the idler pulley tension spring.
2. Slip the belt off the pulley.
3. Install a new belt.
4. Assemble idler tension spring.
5. Align pulleys and belts if necessary.

Main Broom Adjustment

The main broom should be periodically readjusted as needed to compensate for wear. Use the broom-adjusting lever to accomplish this. rotate counterclockwise to lower and clockwise to raise. (See Fig. 2, page 6)

Side Broom Belt Adjustment

To increase tension on the side broom belt, loosen the two (2) socket set screws. Push the split clamp forward on the tubular frame until belt is sufficiently tight to drive broom without slipping. Tighten clamp screws.

Friction Drive Wheel

The friction drive wheel should be adjusted so it touches the mating drive wheel. The machine should **NOT creep** or move when the operator handle is in neutral "UP" position. (See Fig. 10)

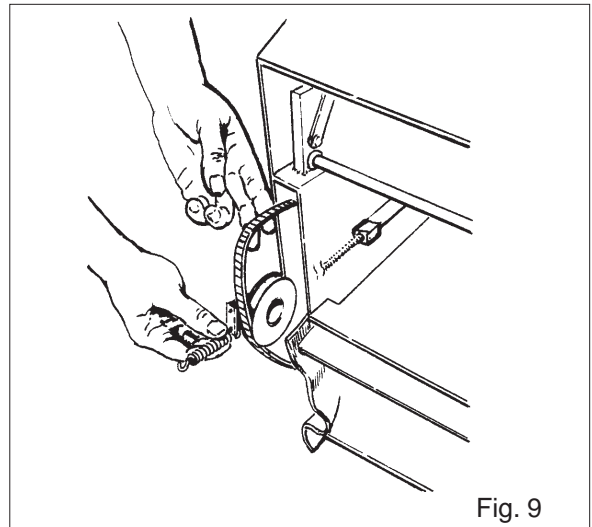

Fig. 9

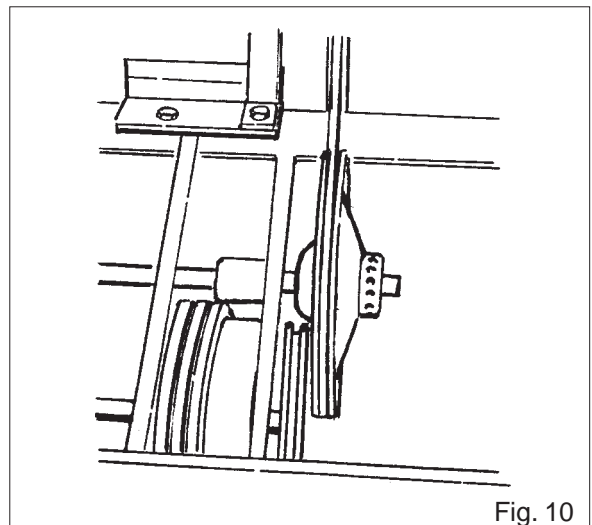

Fig. 10

ENGINE SPEED ADJUSTMENT (Model 28G)

The engine speed (rpm) is governor-controlled and preset at the factory at 2150 rpm (no load). Should it be necessary to check or readjust this setting, use a good strobe tachometer and adjust the governor rod threaded end to maintain 2150 rpm (no load). Be certain all brooms are raised for this adjustment.

Installation of new Main Brush

The main brush is made up of five (5) bristle strips, installed and retained on the core by three (3) screws and washers for each strip. Do not change (1) new bristle strip with (4) worn strips.

Remove the three screws and washers and the bristle strip retained by them. Install the new strip and assemble the retaining screws and washers. Be sure to install the "V" of each strip in the same relation to the core as its companion strips. (See Fig. 11)

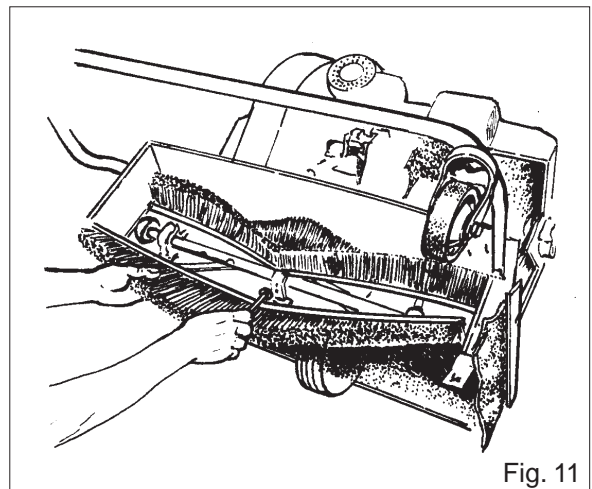

Fig. 11

Installation of New Main Brush (cont)

Remove the three screws and washers and the bristle strip retained by them. Install the new strip and assemble the retaining screws and washers. Be sure to install the "V" of each strip in the same relation to the core as its companion strips. (See Fig. 11, page 11)

CAUTION: The strips must be carefully centered on the core before they are firmly locked into position. Rotate the broom by hand through a full revolution to check for possible interference with the shaft carriers at each end. Failure to check this area could result in damage to the drive mechanism.

Continue to replace one strip at a time, checking end clearance on each end, until all strips have been replaced with new fillers.

Readjust the broom to allow for the new bristle strips.

The main brush is preadjusted at the factory to insure even engagement with the floor across its full width. However, should the brush show signs of uneven wear, end to end, compensating adjustments may be made. Raise or lower either end as required by changing the length of the adjusting rod. (See fig. 12)

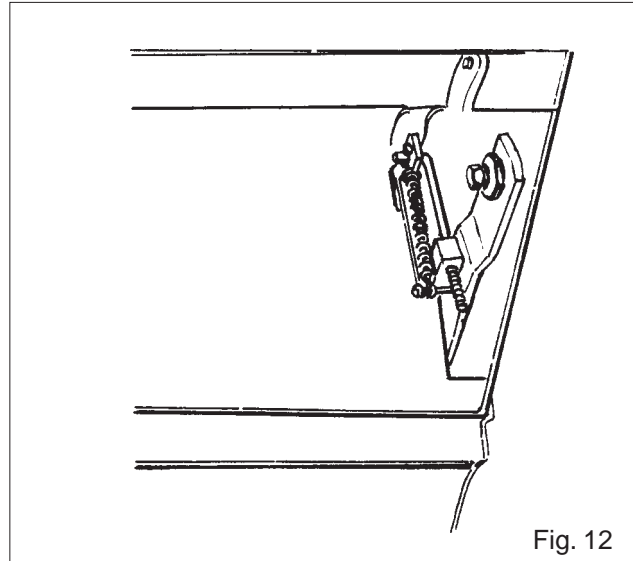

SHOPEVALUATION OF CHARGERS

(Qualified Service Personnel Only)

Service Hints

1. Check the AC power supply (plug, cords, building fuses and switched, etc.)
2. Check for physical damage.
3. If there is no DC output, check for blown internal fuse(s); blown fuses may be caused by reversed DC connections or by a defective diode.
4. Check parts - ammeter, timer-switch, diodes, transformer and fuses for tight connections and for discoloration due to electrical failure.

WARNING: Always wear eye and face shield, and protective clothing when working with batteries to avoid injury.

5. Check the condition of the batteries.
 - a. Specific gravity (1.280 is ideal for fully charged batteries).
 - b. The battery bank voltage should come up to about 30.7 volts at the end of the cycle.
 - c. The DC charging current should start in the "normal" range and end in the "finish" range.

If the charger is still inoperative after the above checks have been made, call your nearest authorized service center.

Capacitor Test

If a commercial capacitor checker is not available, the following test may be made:

1. Briefly short the capacitor terminals together with a screwdriver.
2. Disconnect a wire from either capacitor terminal.
3. Adjust an ohmmeter to a high value such as RX10K or RX1 Meg.
4. Connect the ohmmeter leads to the capacitor terminals.
5. A good capacitor will cause the indicator to move quickly to zero ohms, then slowly return to infinite ohms. An open capacitor will not cause any indicator movement; a shorted capacitor will give a continuous zero ohms reading.
6. If the test is to be repeated, the capacitor terminals must again be shorted together briefly.

Diode Test

1. You must have a #308 ct. Everready continuity tester or equivalent/
2. Desolder both wires from the diode lead connections. (Clamp heatsink pliers on the diode leads to avoid damaging the diodes.)
3. Attach one of the test unit leads to either diode lead.
4. Attach the other test unit lead to the diode heatsink.
5. Turn the test unit on and note if the test unit bulb lights.



DANGER: Reversing charge or polarity of wiring could cause batteries to **EXPLODE** causing serious bodily harm to yourself or others.

- 6.. Reverse the test unit leads in Steps 3 and 4.
7. Turn the test unit on and note if the test unit bulb lights.
8. **Good diode** - test light bulb should light up in one of Steps 5 and 7 and not in the other.

Defective diode - test bulb will light up in both Steps 5 and 7.

Defective Diode - Test bulb will not light up in either Steps 5 or 7.

Clarke®
Model SPS-28
Main Frame, Brush Assembly and Drive System Drawing 1/99

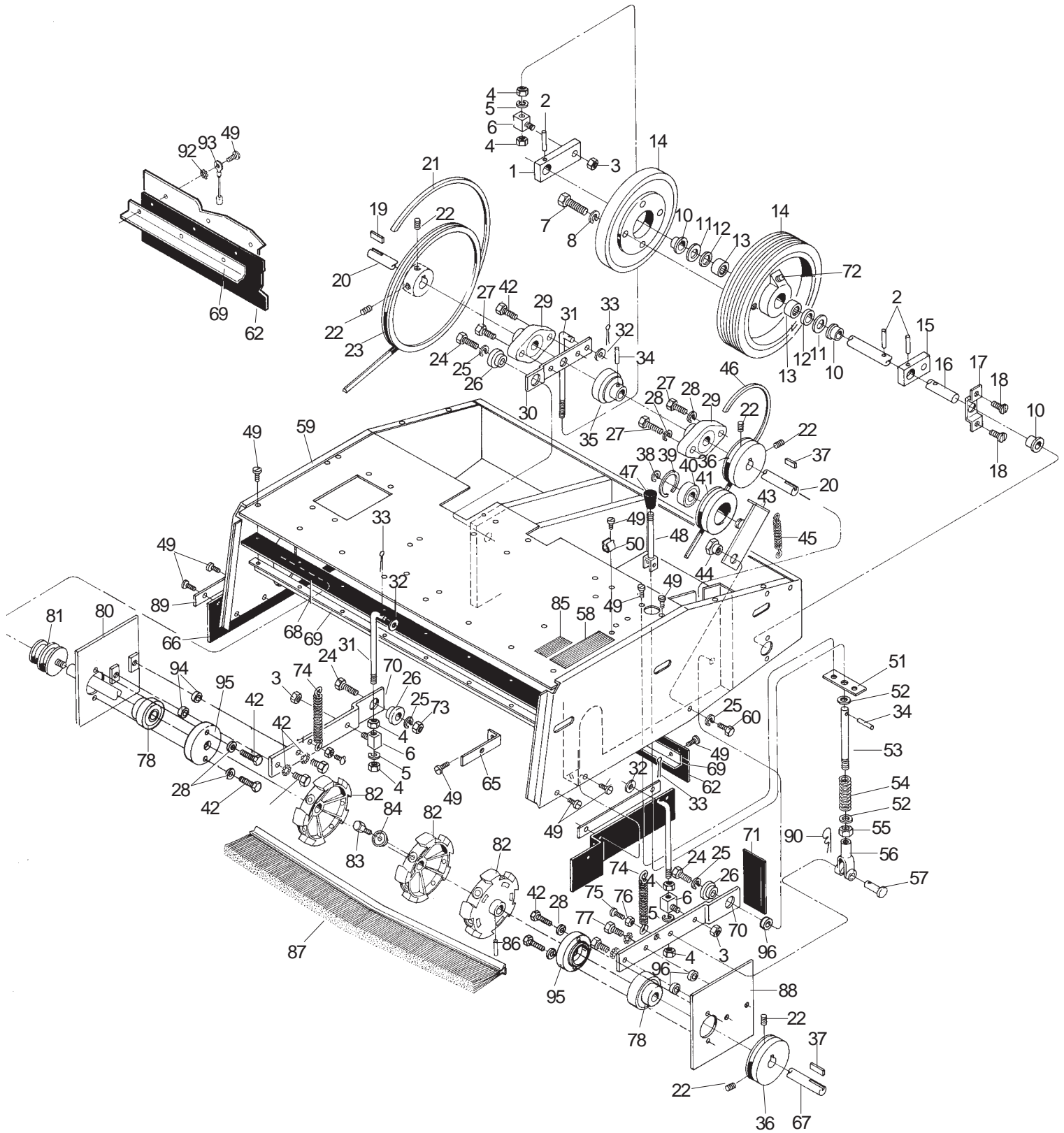

Clarke®
Model SPS-28
Main Frame, Brush Assembly and Drive System Parts Lists 1/99

Ref #	Part No.	Description	Qty	Ref #	Part No.	Description	Qty
1	790322	Arm, Lower Clutch, R.H.	1	50	302101	Clamp	1
2	925543	Pin, 1/8 x 1 1/4 Roll	3	51	796623	Plate, Brush Lift	1
3	920349	Nut, 1/4-20	3	52	791121	Bushing, Spring	2
4	920160	Nut 5/16 - 18 Hx Jam	6	53	797423	Rod, Brush Lift	1
5	980652	Washer 5/16 Lock	3	54	858302	Spring	1
6	791323	Block, Pedal Pivot	3	55	920329	Nut, 5/16 -24 Hex	1
7	85813A	Screw 5/16 -18 x 1" Hx	4	56	809904	Yoke	1
8	980652	Washer 5/16 Lock	8	57	806705	Pin	1
9	799728	Wheel	1	58	795121	Label, Instruction	1
10	902710	Bearing, Wheel Shaft	3	59	60072A	Frame Assembly, Main	1
11	980023	Washer, Thrust	2	60	962302	Screw, 3/8 x 16 x 5/8 Hex	1
12	877661	Seal, Oil	2	61			
13	902682	Bearing, Wheel	2	62	798526	Skirt, Brush Rear	1
14	799729	Wheel	1	63	798528	Skirt, Brush L.H.	1
15	790326	Arm, Lower clutch, L.H.	1	64	797225	Retainer, L.H. Skirt	1
16	797721	Shaft, Wheel	1	65	797224	Retainer, L.H. Skirt	1
17	798530	Support, Wheel Bearing	1	66	798527	Skirt, Brush R.H.	1
18	962385	Screw, 10-24 x 1/2	2	67	797722	Shaft, Brush	1
19	915044	Key, 3/16 x 3/16 x 1	1	68	798525	Skirt, Hopper Top	1
20	797727	Shaft, Brush Drive	1	69	797221	Retainer	2
21	903540	Belt, Drive	1	70	790337	Arm, Brush	2
22	962103	Screw, 5/16 -18 x 3/8	6	71	797620	Seal, Brush Arm	2
23	796920	Pulley, Driven	1	72	883351	Grease Fitting	1
24	962686	Screw, 5/16 -18 x 1 1/2 Hx	2	73	920260	Nut, 3/8 -16 x 5/16 Hex	2
25	980638	Washer, 3/8 "Lock	4	74	53038A	Spring	2
26	808256	Spacer, Parallel Arm Rear	3	75	962139	Screw, 1/4-20 x 5/8 Hex	2
27	962219	Screw, 1/4-20 x 7/8 Hex	2	76	920208	Nut, 1/4-20	2
28	980657	Washer, 1/4 Lock	2	77	962709	Screw, 1/4-20 x 1/2 Hex	4
29	902713	Bearing	2	78	902746	Bearing, Brush Shaft	2
30	790324	Arm, Clutch	1	79			
31	797422	Rod, Brush Lift	3	80	797829	Shield Assembly, Broom Dust	1
32	980651	Washer, 5/16 Plain	3	81	796922	Pulley, Side Broom Drive	1
33	925036	Pin, 3/32 x 3/4 Cotter	3	82	792703	Driver, Brush	3
34	925550	Pin, 1/8 x x 1" Roll	1	83	962893	Screw 1/4-20 x 7/8 Hex	15
35	799727	Wheel, Friction Drive	1	84	797205	Retainer	15
36	796921	Pulley, Brush Drive	2	85	920364	Nut, 1/4-20 speed	15
37	915076	Key, 3/16 x 3/16 x 9/16 Ling Sq.	2	86	925070	Pin, 1/4 x 1 1/2 Roll	3
38	167308	Retaining Ring	1	87	790923	Brush Segment Carpet	10
39	857301	Retaining Ring	1		790920	Brush Segment 28"	5
40	902659	Bearing	1	88	797828	Shield Assembly, Broom Dust L.H.	1
41	796926	Pulley, Brush Drive Idler	1	89	797223	Retainer, R.H. Skirt	1
42	962455	Screw, 1/4-20 x 1" Hex	6	90	856702	Pin, Hair, cotter	1
43	790320	Arm Assembly, Idler Pulley	1	91	797235	Retainer, Brush Strp. (Std Mach. Only)	15
44	798220	Spacer, clutch Arm	1	92	980675	Washer, #10 Shakeproof	1
45	858345	Spring, Bracket Adjusting Screw	1	93	798541	Strap, Static Discharge	1
46	903539	Belt, Brush Drive	1	94	798232	Spacer	2
47	815051	Knob, Handle	1	95	797236	Retainer	2
48	793923	Handle Assembly, Brush Lift	1	96	858207	Spacer	2
49	962546	Screw, 10 x 1/2 Rd. Hd. Type 23	26				

Clarke®
Model SPS-28
Engine, Dust Control & Handle Assembly Drawing 11/02

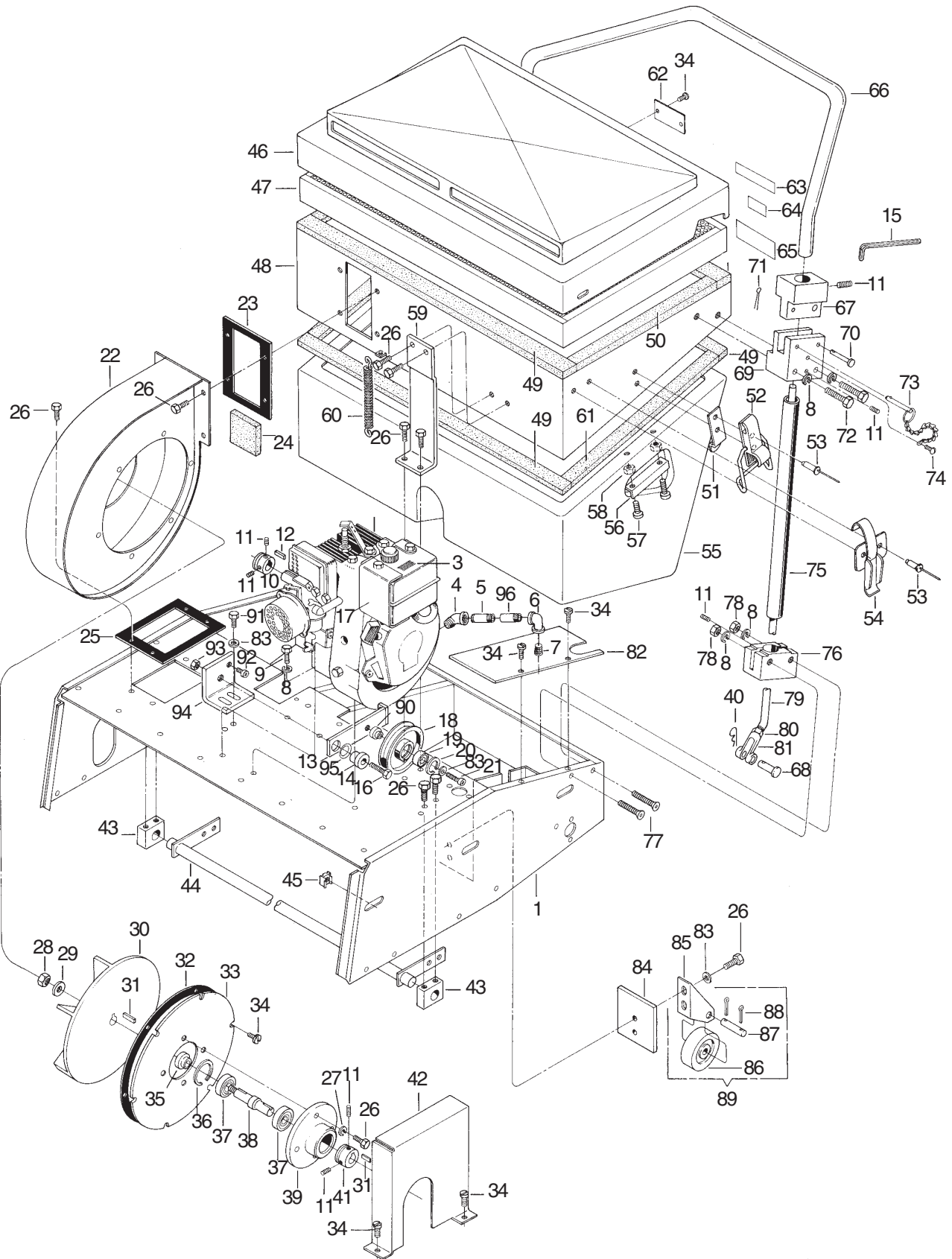

Clarke®
Model SPS-28
Engine, Dust Control & Handle Assembly 11/02

Ref #	Part No.	Description	Qty	Ref #	Part No.	Description	Qty
1	60072A	Frame, Main	1	51	793820	Guide, Dust Hopper	2
2	792920	Engine, 5 H.P. Briggs and Stratton	1	52	682006	Clamp Assembly, Lid	2
3	285161	Label, Gasoline	1	53	930086	Rivet, ³ / ₁₆ x .450 Long	10
4	722824	Elbow, ¹ / ₄ x 45° Street Brass	1	54	285102	Latch, Inspection Door	3
5	755721	Nipple, ¹ / ₄ x 2 ¹ / ₂ " Brass	1	55	30315R	Hopper, Dust	1
6	822806	Elbow, ¹ / ₄ x 90° Brass	1	56	797226	Retainer, Dust Hopper	2
7		Drain Plug - Part of Engine		57	962385	Screw 10- 24 x ¹ / ₂ Bdg. Hd.	4
8	822806	Washer ⁵ / ₁₆ Lock	8	58	920200	Nut, 10 - 24 Hex	4
9	196157	Screw, ⁵ / ₁₆ -18 x 1 ¹ / ₄ Hex	4	59	790832	Bracket, Dust Housing Support	1
10	796924	Pulley, Engine	1	60	53038A	Spring	1
11	962103	Screw, ⁵ / ₁₆ -18 x ³ / ₈ Set	8	61	793425	Gasket, Dust chamber Bottom	2
12	915044	Key ³ / ₁₆ x ³ / ₁₆ x 1" Square	1	62		Serial No. Plate - Gasoline (Blank)	1
13	790335	Arm, Assembly	1			Serial No. Plate - Battery (Blank)	1
14	798231	Spacer, Parallel Arm Rear	1	63	215104	Label, Warning	1
15	987013	Wrench, Allen ⁵ / ₃₂ "	1	64	755129	Label, Patent Pending	1
16	962216	Screw, ³ / ₈ x 16 x 1" Hex	1	65	795120	Label, Instruction	1
17	793624	Guard, Gas Tank	1	66	793920	Handle, Upper	1
18	796925	Pulley, Idler	1	67	790825	Bracket, Handle Pivot	2
19	902659	Bearing	1	68	806705	Pin	1
20	857301	Retaining Ring	1	69	790824	Bracket, Handle	2
21	962454	Screw, ¹ / ₄ -20 x 1"	1	70	796721	Pin, Handle Pivot	2
22	60073A	Housing Assembly, Blower	1	71	925004	Pin, ¹ / ₁₆ x ¹ / ₂ Cotter	2
23	793424	Gasket, Duct to Filter	1	72	85818A	Screw, ⁵ / ₁₆ - 18 x 2 ¹ / ₂ Hex	4
24	791221	Bumper, Dust Hopper	1	73	796720	Pin Assembly, Handle Release	2
25	793423	Gasket, Duct to Frame	1	74	85392A	Screw 6-32 x ³ / ₈ Pan Hd	2
26	962709	Screw ¹ / ₂ Sems	20	75	793922	Handle, Lower	2
27	980657	Washer ¹ / ₄ Lock	4	76	798524	Support, Handle	2
28	920110	Nut, ⁵ / ₁₆ -18 Elastic Stop	1	77	962894	Screw, ⁵ / ₁₆ - 18 x 2 ¹ / ₂	4
29	980210	Washer, Impeller	1	78	920160	Nut, ⁵ / ₁₆ - 18 Jam	4
30	614820	Impeller	1	79	797420	Rod, Traverse	1
31	915044	Key, ³ / ₁₆ x ³ / ₁₆ x 1" Square	1	80	920329	Nut, ⁵ / ₁₆ -24 Hex	1
32	793420	Gasket, Blower Mounting Adapter	1	81	809904	Yoke	1
33	790221	Adapter Assembly, Blower Mounting	1	82	62665A	Cover, Frame	2
34	962835	Screw, 10 x 24 x ¹ / ₂ Hx St. Typ F	6	83	980646	Washer, ¹ / ₄ Plain	7
35	618220	Spacer, Impeller	1	84	796631	Plate, Stabilizer Whl. Stiffner	2
36	067304	Snap Ring	1	85	798537	Support, Rear Wheel	2
37	902550	Bearing	2	86	419702	Wheel	2
38	617704	Shaft, Impeller	1	87	796722	Pin, Wheel Support	2
39	794224	Housing, Bearing	1	88	925036	Pin, ³ / ₃₂ x ³ / ₄ Cotter	4
40	856702	Pin, Hair Cotter	2	89	799724	Wheel Assembly, Stabilizer	2
41	796923	Pulley, Blower	1	90	798230	Spacer, Idler Pulley	1
42	793620	Guard, Belt	1	91	962086	Screw, ¹ / ₄ -20 x ³ / ₄ Hx Hd.	2
43	790830	Bracket, Lift Shaft	2	92	962799	Screw, ¹ / ₄ -20 x ³ / ₈ Soc. Cap	1
44	797726	Shaft Assembly	1	93	920148	Nut, ³ / ₈ -16 Hex Jam	1
45	920993	Nut, ³ / ₁₆ -18 Panel	6	94	790846	Bracket, Idler Arm	1
46	60074A	Cover, Filter	1	95	980202	Washer Wave	1
47	793320	Filter, Dust	1	96			
48	15724A	Housing Asm., Dust Chamber	1	97	170266	Coupling	1
49	793422	Gasket, Dust Chamber	4				
50	793421	Gasket, Dust Chamber Top	2				

Clarke®
Model SPS-28
Hopper and Optional Sidebroom Assembly Drawing 11/02

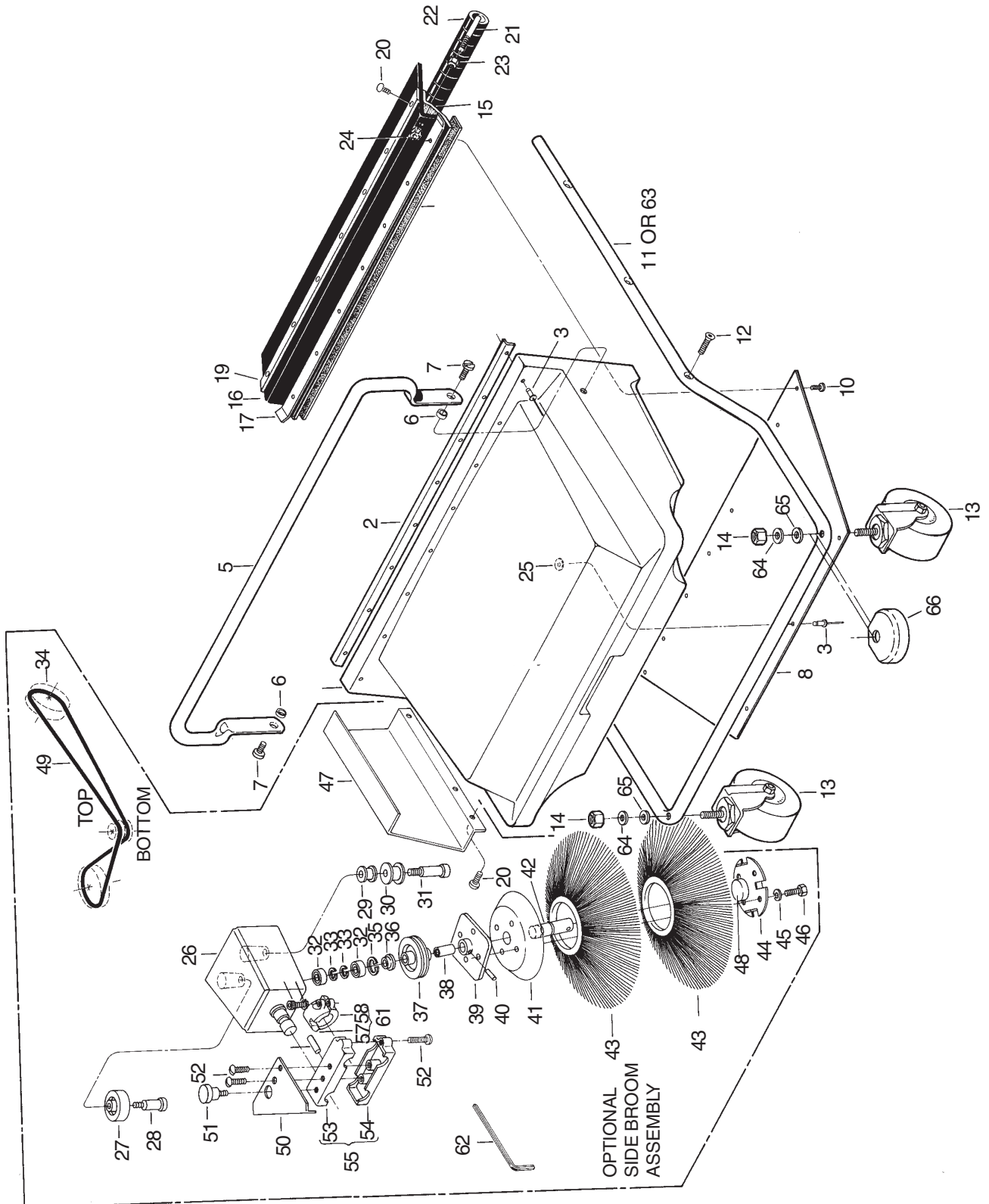

Clarke®
Model SPS-28
Hopper and Optional Sidebroom Assembly Parts List 11/02

Ref #	Part No.	Description	Qty	Ref #	Part No.	Description	Qty
1	30313A	Hopper	1	35	857301	Ring, Retaining	1
2	798529	Support, Hopper Top	1	36	798205	Spacer	1
3	930090	Rivet, ⁵ / ₃₂ Dia.	8	37	796901	Pulley, Side Brush Drive	1
5	793921	Handle, Hopper	1	38	792401	Clutch	1
6	798203	Spacer, Carrying Handle	2	39	794320	Hub, Side Brush	1
7	962568	Screw, ⁵ / ₁₆ -18 x ½ Bdg. Hd.	2	40	925062	Roll Pin	1
8	797820	Shield, Hopper	1	41	794001	Holder, Side Brush	1
9	962385	Screw, 10-24 x ½ Bdg. Hd.	3	42	797701	Shaft	1
10	962677	Screw, 10-24 x ¾ Pan Hd.	8	43	790901	Brush, Side	2
11	791220	Bumper, Front	1	44	796420	Plate, Brush Retaining	1
12	962803	Screw ⁵ / ₁₆ -18 x 1½	1	45	980657	Washer, ¼ Lock	5
13	889706	Wheel, Swivel	2	46	962481	Screw, ¼-20 x 1¼ Hx Cap	4
14	920196	Nut ½-13 ESNA	2	47	793621	Guard, Side Broom Belt	1
15	790823	Bracket, Skirt to Hopper	1	48	798228	Spacer	1
16	798523	Skirt, Hopper	1	49	903538	Belt, Side Brush Round	1
17	797220	Retainer, Lower Skirt	1	50	793622	Guard, side Brush	1
18	793426	Gasket, Hopper	1	51	725020	Knob	1
19	797222	Retainer, Hopper Skirt	1	52	962716	Screw, ¼-20 x 1½	2
20	962073	Screw, 10 - ½ Rd. Hd. Type Z	11	53	790331	Arm, Side Brush, Top	1
21	797421	Rod, Roller	1	54	790331	Arm, Side Brush, Bottom	1
22	797501	Roller	26	55	790331	Arm Assembly, side brush	1
23	920160	Nut, ⁵ / ₁₆ -18 Hex Jam	2	56	925132	Pin, ¼ x ¾	1
24	920110	Nut, ⁵ / ₁₆ -18 Elastic Stop	2	57	792023	Clamp, Top	1
25	920200	Nut, 10-24 Hex Optional Sidebroom Assembly		58	792023	Clamp, Bottom	1
26	794201	Housing, side Brush	1	59	962454	Screw, ¼-20 x 1"	2
27	419702	Wheel	1	60	980657	Washer, ¼ Lock	2
28	960953	Screw, Wheel	1	61	792023	Clamp Asm., Side Brush	1
29	796902	Pulley	1	62	987516	Wrench, ³ / ₁₆	1
30	796903	Pulley	1	63	61300A	Bumper (Carpet Only)	1
31	960970	Shoulder Bolt, Pulley	1	64	980626	Washer, ½ Lock	2
32	902659	Bearing	1	65	980662	Washer (Carpet Only)	2
33	167308	Ring, Retaining	2	66	63900A	Guard, Caster (Carpet Only)	2
34	796922	Pulley, Side Broom Drive	1				

Clarke®
Model SPS-28
Battery Powered Model Drawing 1/99

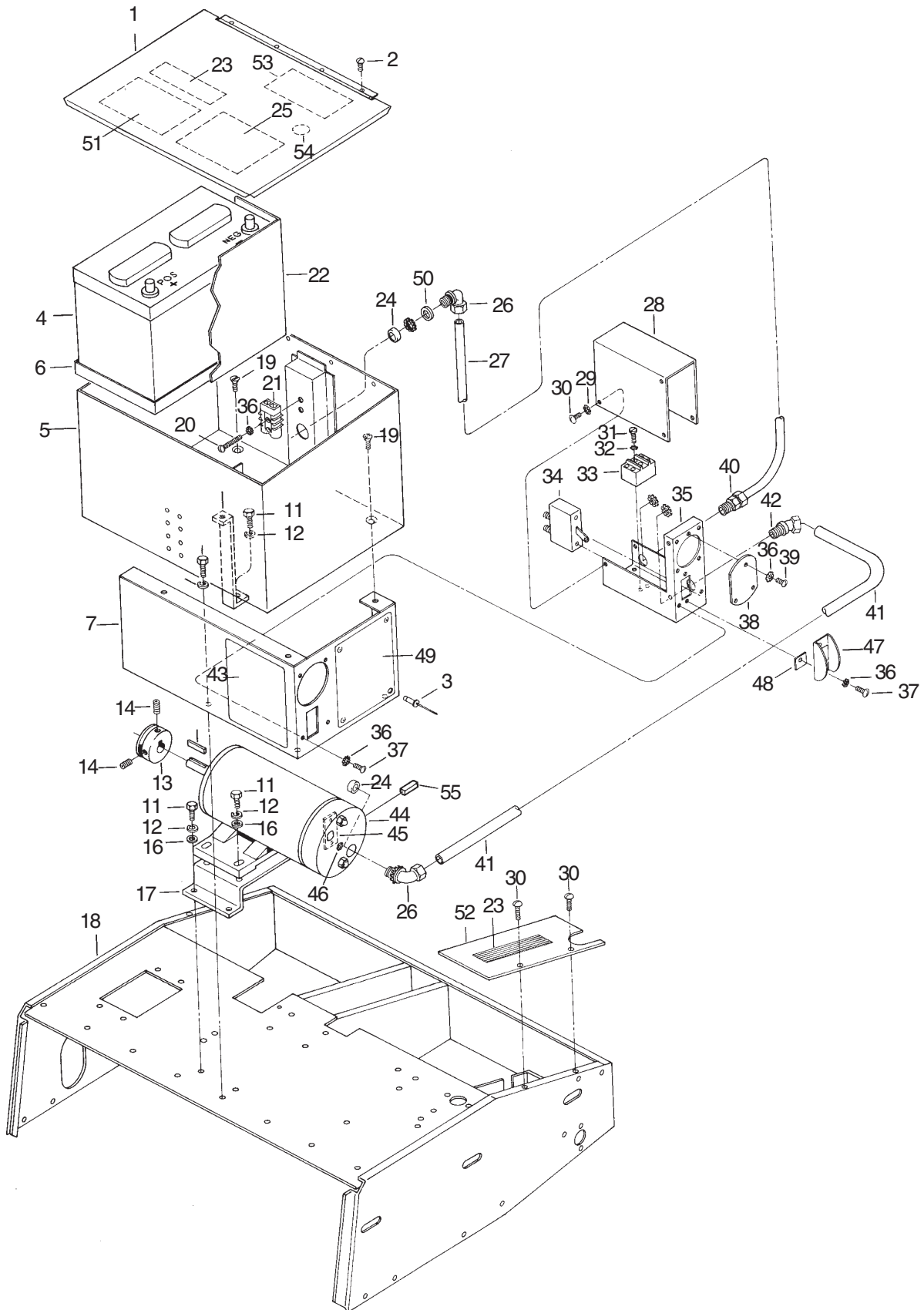

Clarke®
Model SPS-28
Battery Powered Model Drawing 1/99

Ref #	Part No.	Description	Qty
1	60071A	Cover Assembly, Battery Access	1
2	962003	Screw, $\frac{5}{32} \times \frac{3}{8}$ Rd. Hd.	4
3	930093	Rivet, $\frac{1}{8} \times \frac{1}{4} - \frac{5}{16}$ Pop	4
4	871376	Battery, 95 Amp Hr. (Wet)	2
	871377	Battery, 95 Amp Hr. (Dry)	2
5	15726A	Housing Assembly, Battery	1
6	799224	Tray, Battery	2
7	15725A	Housing Assembly, Motor	1
8	962709	Screw, $\frac{1}{4}-20 \times \frac{1}{2}$ Hx St. Sems	3
9	980657	Washer, $\frac{1}{4}$ Lock	6
10	790826	Bracket, Battery Support	1
11	85811A	Screw, $\frac{5}{16} - 18 \times \frac{3}{4}$ Hex Hd.	8
12	980652	Washer $\frac{5}{16}$ Lock	12
13	796927	Pulley, Motor	1
14	962103	Screw, $\frac{5}{16} \times 18 \times \frac{3}{8}$	2
15	915044	Key, $\frac{3}{16} \times \frac{3}{16} \times 1"$ Long Square	1
16	980651	Washer, $\frac{5}{16}$ -Plain	4
17	790827	Bracket Asm., Motor Mounting	1
18	60072A	Main Frame Assembly	1
19	962800	Screw, $\frac{1}{4}-20 \times \frac{1}{2}$ Flat Hd.	4
20	962212	Screw 6-32 x $\frac{7}{8}$ Rd. Hd.	2
21	911470	Wire Assembly, Battery Plug	1
22	797827	Shield, Battery	2
23	795136	Label, Warning	2
24	791120	Bushing, Conduit Insulating	2
25	895196	Label, Warning	1
26	792437	Connector 90° Conduit	2
27	799024	Tubing, Battery Enclosure to Circuit Breaker	1
28	792322	Cover Assembly, Enclosure	1
29	980603	Washer, #1110 Shakeproof	6
30	962546	Screw, 10 x $\frac{1}{2}$ Rd. Hd. Type 23	10
31	962399	Screw, 8-32 x $1\frac{1}{4}$	2
32	980612	Washer #8 Lock	1
33	911438	Block, Terminal	1
34	911440	Switch, Toggle	1
35	792921	Enclosure, Circuit Breaker	1
36	980607	Washer, #1106 Shakeproof	5
37	962045	Screw, 6-32 x $\frac{1}{4}$ Rd. Hd.	2
38	792325	Cover, enclosure	1
39	962330	Screw, 6-32 x $\frac{3}{8}$ Rd. Hd.	3
40	792438	Connector, Straight Conduit	1
41	799021	Tubing, Circuit Breaker to Motor	1
42	792436	Connector, 45° Conduit	1
43	795145	Label, Wiring Diagram	1
44	795220	Motor, Drive 24 Volt DC	1
45	794720	Insulation, Paper (Motor)	1
46	980614	Washer, #1114 Shakeproof	2
47	793623	Guard, Switch	1
48	792337	Cover, Switch Guard	1
49	796327	Plate, Safety Label (Eng. Sp.)	1
50	980303	Washer	1
51	895178	Label, Battery Care Instruction	1
52	62665A	Cover, Frame	2
53	795151	Label, Battery Size	1
54	795143	Label, UL Decal	1
55	790926	Brush, Motor	1

Clarke®
Model SPS-28
Wiring Diagram & Electrical Schematic 1/99

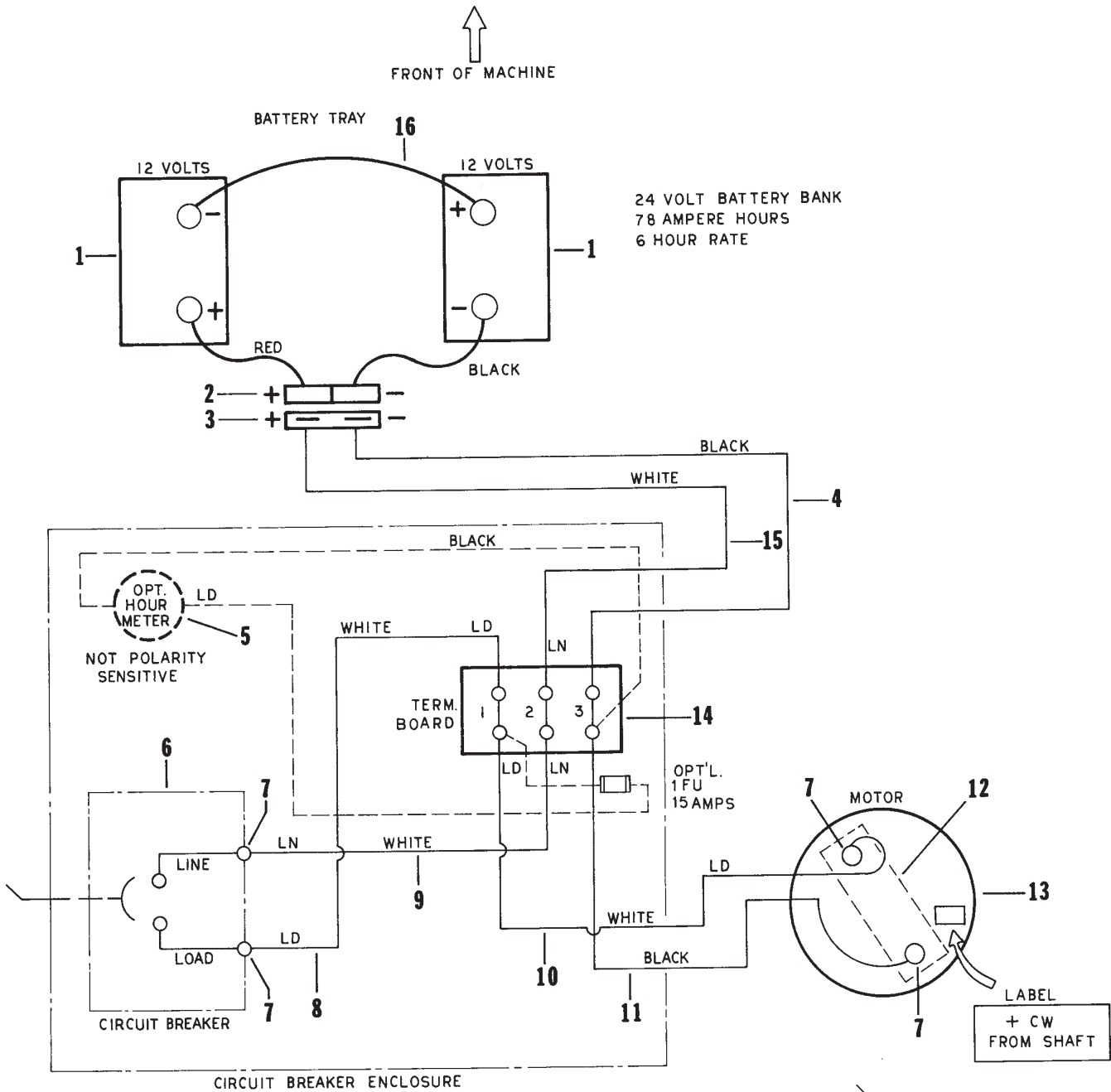

↑
CONNECTION DIAGRAM

SCHEMATIC DIAGRAM →

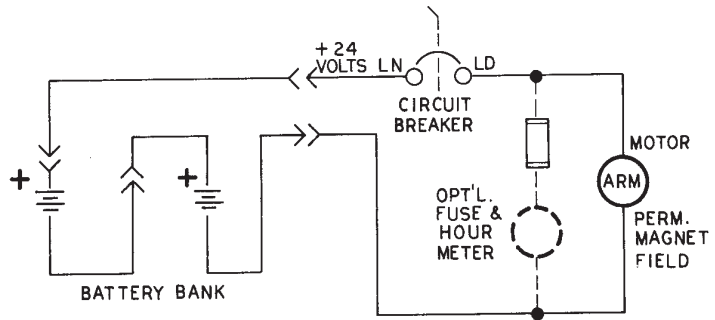

⚠ WARNING – All electrical repairs must be done by authorized personnel.

Clarke®
Model SPS-28
Wiring Diagram 1/99

Ref #	Part No.	Description	Qty
1	871376	Battery, 95 amp Hr. (Wet)	2
	871377	Battery, 95 amp Hr. (Dry)	2
2	41207A	Cable, Battery	1
3	911470	Connector	1
4	951006	Wire Assembly	1
5	855607	Hour Meter (Optional)	1
6	911440	Circuit Breaker	1
7	980614	Washer, ¼ External Tooth	4
8	950807	Wire Assembly, #10 White	1
9	950806	Wire Assembly, #10 White	1
10	950805	Wire Assembly, Terminal Board - Mtr.	1
11	951004	Wire Assembly, #10 Black	1
12	794720	Insulator Motor	1
13	795220	Motor, Drive	1
14	911438	Block, Terminal	1
15	950813	Wire Assembly	1
16	842406	Cable	1

CLARKE PRODUCT SUPPORT BRANCHES

U. S. A. Locations

PRODUCTION FACILITIES

Clarke®, Springdale, Arkansas
2100 Highway 265
Springdale, Arkansas 72764
(479) 750-1000
Customer Service - 1-800-253-0367
Technical Service - 1-800-356-7274

American Lincoln®, Bowling Green, Ohio 43402
1100 Haskins Road

SERVICE FACILITIES

Clarke®, Elk Grove, Illinois 60007
2280 Elmhurst Road
(847) 956-7900

Clarke®, Denver, Colorado 80204
1955 West 13th Ave.
(303) 623-4367

Clarke®, Houston, Texas 77040
7215 North Gessner Road
713-937-7717

SERVICE AND SALES FACILITY

American Lincoln® / Clarke, Madison Heights,
Michigan 48071-0158
29815 John R.
(810) 544-6300

American Lincoln® / Clarke, Marietta, Georgia 30066
1455 Canton Road
(770) 973-5225

Clarke®

Clarke American Sanders

A.L. Cook

Customer Service Headquarters and Factory
2100 Highway 265
Springdale, Arkansas 72764
(479) 750-1000

Technical Service
1-800-356-7274

European Locations

PRODUCTION FACILITIES

ALTO Danmark A/S, Aalborg
Blytaekervej 2
DK-9000 Aalborg
+45 72 18 21 00

ALTO Danmark A/S, Hadsund
Industrikvarteret
DK-9560 Hadsund
+45 72 18 21 00

SALES SUBSIDIARIES

ALTO US - Canada, Ontario (Canada)
4080 B Sladeview Crescent Unit 1
Mississauga, Ontario L5L 5Y5
(905) 569 0266

ALTO Overseas Inc., Sydney (Australia)
1B/8 Resolution Drive
Caringbah NSW 2229
+61 2 9524 6122

ALTO Cleaning Systems Asia Pte Ltd., Singapore
No. 17 Link Road
Singapore 619034
+65 268 1006

ALTO Deutschland GmbH, Bellenberg (Germany)
Guido-Oberdorfer-Straße 2-8
89287 Bellenberg
+49 0180 5 37 37 37

ALTO Cleaning Systems (UK) Ltd., Penrith
Gilwilly Industrial Estate
Penrith
Cumbria CA11 9BN
+44 1768 868 995

ALTO France S.A. Strasbourg
B.P. 44, 4 Place d'Ostwald
F-67036 Strasbourg
Cedex 2
+33 3 8828 8400

ALTO Nederland B.V.
Postbus 65
3370 AB Hardinxveld-Giessendam
The Netherlands
+31 184 677 200

ALTO Sverige AB, Molndal (Sweden)
Aminogatan 18
Box 4029
S-431 04 Molndal
+46 31 706 73 00

ALTO Norge A/S, Oslo (Norway)
Bjornerudveien 24
N-1266
+47 2275 1770

Clarke® LIMITED U.S. WARRANTY

This Clarke Industrial/Commercial Product is warranted to be free from defects in materials and workmanship under normal use and service for a period of one year from the date of purchase, when operated and maintained in accordance with Clarke's Maintenance and Operations instructions.

This warranty is extended only to the original purchaser for use of the product. It does not cover normal wear parts such as electrical cable, rubber parts, hoses and motor brushes.

If a difficulty develops with the product, you should:

- a) Contact the nearest authorized Clarke repair location or contact the Clarke U.S. Service Operations Department, 2100 Highway 265, Springdale Arkansas 72764, for the nearest authorized Clarke repair location. Only these locations are authorized to make repairs to the product under this warranty.
- b) Return the product to the nearest Clarke repair location. Transportation charges to and from the repair location must be prepaid by the purchaser.
- c) Clarke will repair the product and/or replace any defective parts without charge within a reasonable time after receipt of the product.

Clarke's liability under this warranty is limited to repair of the product and/or replacement of parts and is given to purchaser in lieu of all other remedies, including INCIDENTAL AND CONSEQUENTIAL DAMAGES.

THERE ARE NO EXPRESS WARRANTIES OTHER THAN THOSE SPECIFIED HEREIN. THERE ARE NO WARRANTIES WHICH EXTEND BEYOND THE DESCRIPTION OF THE FACE HEREOF. NO WARRANTIES, INCLUDING BUT NOT LIMITED TO WARRANTY OF MERCHANTABILITY, SHALL BE IMPLIED. A warranty registration card is provided with your Clarke product. Return the card to assist Clarke in providing the performance you expect from your new floor machine.

Clarke®, 2100 Highway 265, Springdale, Arkansas 72764.

Clarke reserves the right to make changes or improvements to its machine without notice.

Always use genuine Clarke Parts for repair.

Clarke®

**2100 Highway 265
Springdale, Arkansas, 72764**