

Clarke®

Operator's Manual

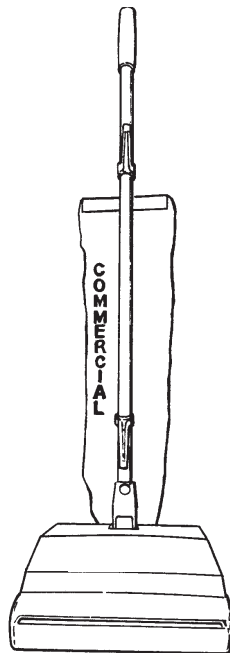

Model 560 B

READ THIS BOOK

This book has important information for the use and safe operation of this machine. Failure to read this book prior to operating or attempting any service or maintenance procedure to your Clarke machine could result in injury to you or to other personnel; damage to the machine or to other property could occur as well. You must have training in the operation of this machine before using it. If your operator(s) cannot read this manual, have it explained fully before attempting to operate this machine.

Si Ud. o sus operadores no pueden leer el Inglés, se hagan explicar este manual completamente antes de tratar el manejo o servicio de esta máquina.

All directions given in this book are as seen from the operator's position at the rear of the machine.

For new books write to: Clarke®, 2100 Highway 265, Springdale, Arkansas 72764.

Table of Contents

Operator Safety Instructions	3
How To Prepare The Machine For Operation	4
How To Assemble the Handle	4
How To Install the Dust Bag	4
How To Install the Paper Filter Bag	5
How To Start the Machine	5
How To Change the Brush Segments	5
Instructions for Connection to the Power Supply and the Electrical Ground	6
Maintenance	7
Assembly Drawing	8
Parts List	9

OPERATOR SAFETY INSTRUCTIONS



WARNING



AVERTISSEMENT



ADVERTENCIA



DANGER:

Failure to read and observe all **DANGER** statements could result in severe bodily injury or death. Read and observe all **DANGER** statements found in your Owner's Manual and on your machine.



WARNING:

Failure to read and observe all **WARNING** statements could result in injury to you or to other personnel; property damage could occur as well. Read and observe all **WARNING** statements found in your Owner's Manual and on your machine.



CAUTION:

Failure to read and observe all **CAUTION** statements could result in damage to the machine or to other property. Read and observe all **CAUTION** statements found in our Owner's Manual and on your machine.



DANGER:

Failure to read the Owner's Manual prior to operating or attempting any service or maintenance procedure to your Clarke machine could result in injury to you or to other personnel; damage to the machine or to other property could occur as well. You must have training in the operation of this machine before using it. If your operator(s) cannot read English, have this manual explained fully before attempting to operate this machine.



DANGER:

Operating a machine that is not completely or fully assembled could result in injury or property damage. Do not operate this machine until it is completely assembled. Inspect the machine carefully before operation.



DANGER:

Machines can cause a fire when operated near flammable materials and vapors. Do not use this machine with or in areas near flammable fluids, fuels, grain dust, solvents, thinners, vapors or other flammable materials. This machine is not suitable for picking up hazardous dust.



WARNING:

To prevent electrical shock, always remove the electrical plug from the electrical outlet before doing any repairs or maintenance to this machine.



WARNING:

To prevent injury, always remove the electrical plug from the electrical outlet before changing the brush or accessories and before leaving the machine.



WARNING:

Maintenance and repairs performed by unauthorized personnel could result in damage or injury. Maintenance and repairs must be performed by authorized Clarke Technology personnel only.



WARNING:

Any alterations or modifications of this machine could result in damage to the machine or injury to the operator or other bystanders. Alterations or modifications not authorized by the manufacturer voids any and all warranties and liabilities.



WARNING:

To prevent electrical shock, do not use this machine on wet surfaces. Electrical components of this machine can "short-out" if exposed to water or moisture. Keep the electrical components of the machine dry. Protect the machine from rain. For storage, keep the machine in a dry building. Always clean the machine with a clean dry cloth.



WARNING:

To prevent damage to the power cord, do not let the brush touch the power cord when the machine is running. Always lift the cord over the machine.



WARNING:

Operating a machine without observing all labels and instructional information could result in injury or damage. Read all machine labels before attempting to operate. Make sure all of the labels and instructional information are attached or fastened to the machine. Get replacement labels and decals from your distributor.



CAUTION:

Use of this machine to move other objects or to climb on could result in injury or damage. Do not use this machine as a step or furniture. Do not ride on this machine.

HOW TO PREPARE THE MACHINE FOR OPERATION

To assemble the handle do the following:

1. Connect the handle sections together with two hexagon screws (see figure 1).
2. Fasten the handle into the housing with a locking screw (see figure 2).

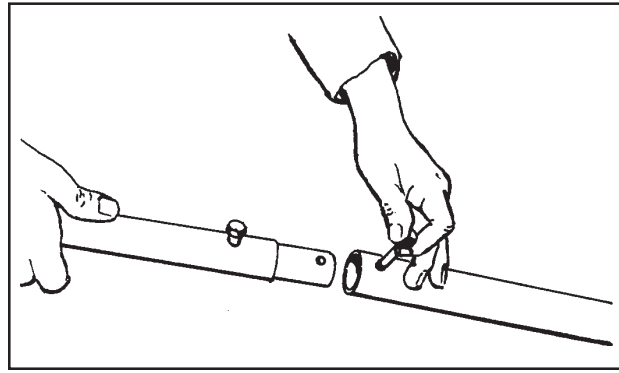

Figure 1

To install the dust bag follow this procedure:

1. Loosen the knobs (see figure 3, #1) at the rear opening of the housing.
2. Slide the bag adaptor opening (see figure 3, #2) up and around the knobs.
3. Tighten the knobs.
4. Fasten the dust bag to the clip on the handle (see figure 4.)

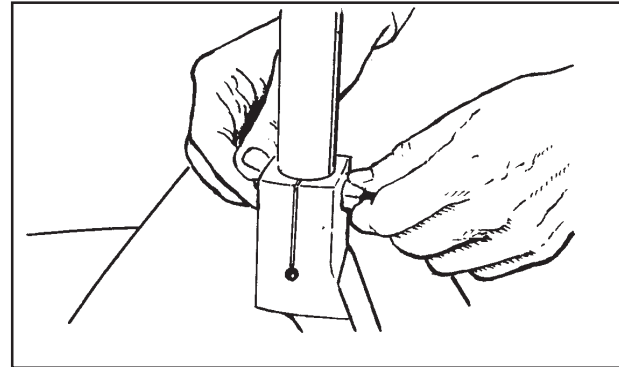

Figure 2

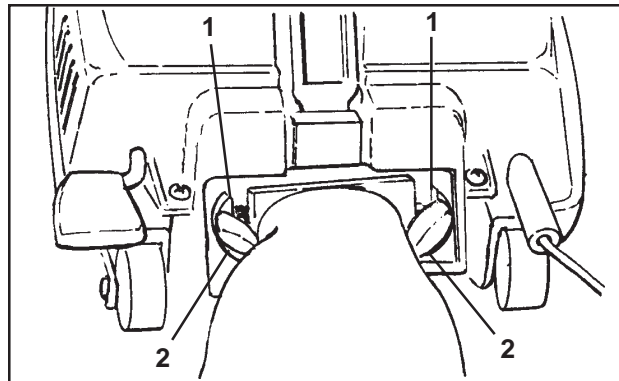

Figure 3

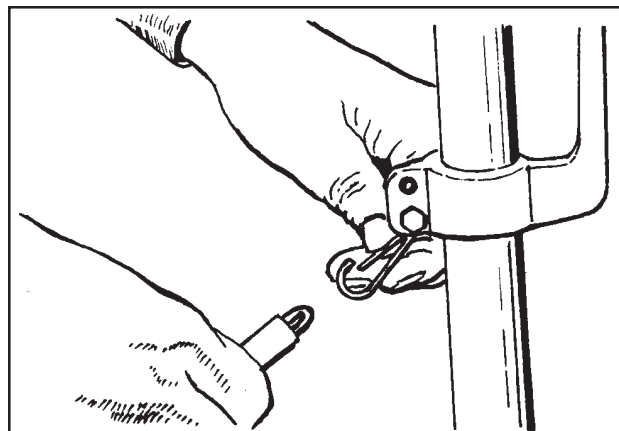

Figure 4

HOW TO PREPARE THE MACHINE FOR OPERATION

To install the paper filter bag, follow this procedure:

1. Push the rubber collar opening around the connector socket (see figure 5.)
2. Close the cloth dust bag.
3. Slide the clamp over the folded edge of the dust bag. Make sure the paper bag is included (see figure 6.)

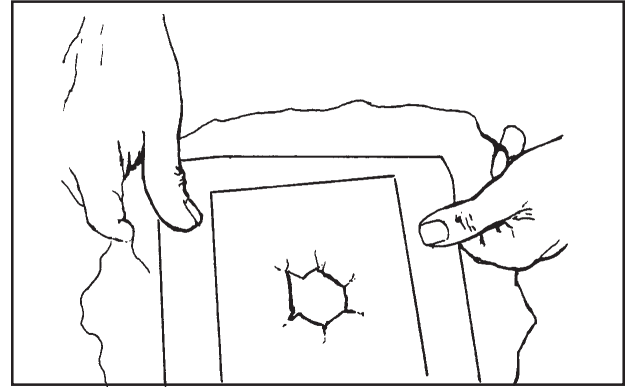

Figure 5

To start the machine, do the following:

1. Step on the release lever.
2. Lower the handle (see figure 7.)

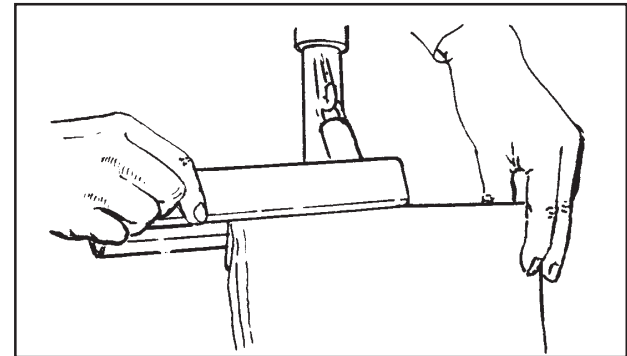

Figure 6

When the brush bristles become worn, replace the brush segments. To change the brush segments, follow this procedure:

1. Turn the levers (figure 8, #1), that hold the plate, to the left.
2. Remove the nozzle plate (figure 8, #2).
3. Remove the brush roller (figure 8, #3).
4. Remove the four screws from each half (figure 8, #4).
5. Install the new brush sections.

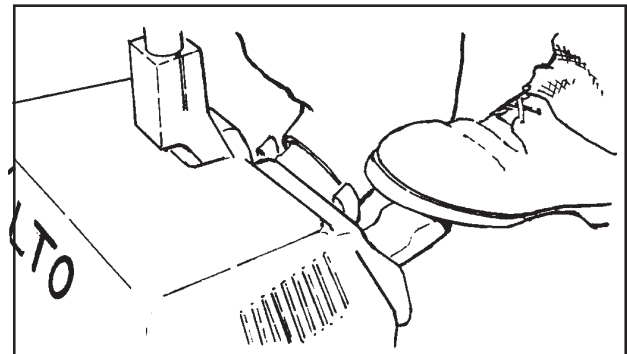

Figure 7

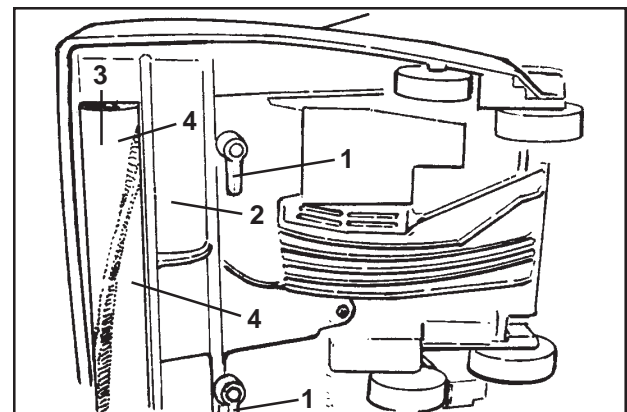

Figure 8

INSTRUCTIONS FOR CONNECTION TO THE POWER SUPPLY AND THE ELECTRICAL GROUND

This machine must be connected to the electrical ground to protect the operator from electric shock. The machine has an approved power cord with three conductors and a plug with three terminals. Connect the plug to a receptacle that has three holes and is connected to the electrical ground. The green (or green and yellow) conductor in the cord is the ground wire. Never connect this wire to any terminal other than the ground pin terminal.

This machine uses a 110 to 120 volts AC 60 cycle electrical circuit. Make sure you have the correct frequency and voltage before connecting the power cord to an outlet. The machine has a plug as shown in Figure 9(A). If a receptacle connected to the electrical ground (A) is not available, use an adapter as shown in Figure 9(C). This adapter must be connected as shown in Figure 9(B) to an electrical ground in the electrical outlet. Make sure you use a plate screw and the ground tab to fasten the adapter.

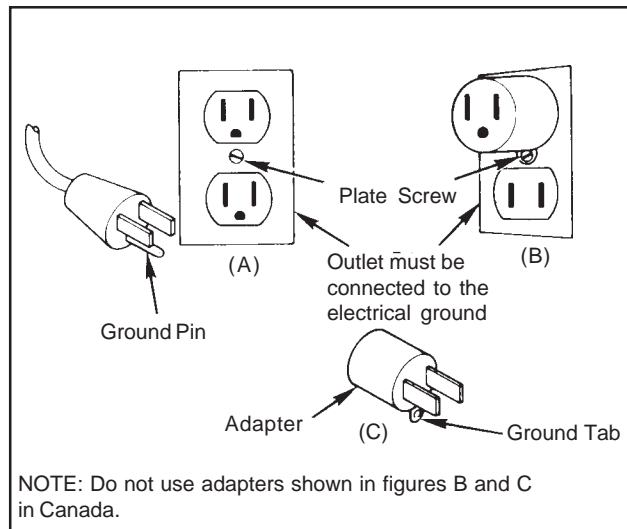

Figure 9

WARNING: Always use this machine with an AC three-conductor electrical system connected to the electrical ground. Replace any worn, cut or damaged cords. Replace any damaged plugs, receptacles or connector bodies.

WARNING: For maximum protection against electric shock, use an electrical circuit interrupter. Get this device from your electrical supplier.

WARNING: Do not cut, remove or break the ground terminal. Do not try to fit a three terminal plug into a receptacle or connector body that does not fit the plug. If the receptacle or connector body does not fit the plug, see your authorized dealer to get an authorized person to make the connection.

WARNING: Do not move the machine over an electrical cord. Always lift the cord over the machine.

EXTENSION CORDS

Use only an approved extension cord with three conductors, a plug with three terminals and a connector body with three holes. This machine has a power cord with wire size 18 AWG (AWG means American Wire Gauge).

WARNING: If you use an extension cord, use an extension cord with minimum wire size 16 AWG.

MAINTENANCE

This section describes the procedures that must be done by a person authorized to do maintenance.

Maintenance of the Motor

This machine uses a universal motor that has a commutator and carbon brushes. The commutator and carbon brushes must be checked after every 6 months or every 600 hours of operation, whichever comes first.

WARNING: Electrical inspections must be made by a person authorized to do maintenance. Electrical repairs must be made by a person authorized to make electrical repairs.

WARNING: To prevent electric shock, always remove the electrical plug from the electrical outlet before doing any repairs or maintenance to this machine.

How to Check the Commutator and the Carbon Brushes

To check the commutator and the carbon brushes, follow this procedure:

1. Remove the screws that hold the motor cover and remove the cover.
2. Remove the spring clips that hold the top of the vacuum motor and remove the top of the vacuum motor.
3. Inspect the commutator. Take the machine to an authorized repair location if you see any of the following conditions.
 - a. Small holes in the surface of the commutator. See figure 10A.
 - b. Uneven color - Look for an even dark brown color. Clean areas or very dark areas indicate a problem. See figure 10B.
 - c. High mica - The mica insulation must be lower than the commutator bars. See figure 10C.
4. Remove the carbon brush assemblies and check the carbon brushes. Replace both carbon brush assemblies if either carbon brush is shorter than 1 cm (3/8 inch). If either brush is shorter than 13 mm (1/2 inch), order replacement brushes. Be ready to replace both carbon brushes earlier than the normal inspection time.
5. Install the top of the motor, the motor cover, and the fasteners.

WARNING: The machine must be tested for electrical safety after electrical repairs are made.

NOTE: For the best operation, have the machine checked by an authorized repair person every 12 months. For safe operation and longer life of your machine, use only genuine Clarke Technology replacement parts.

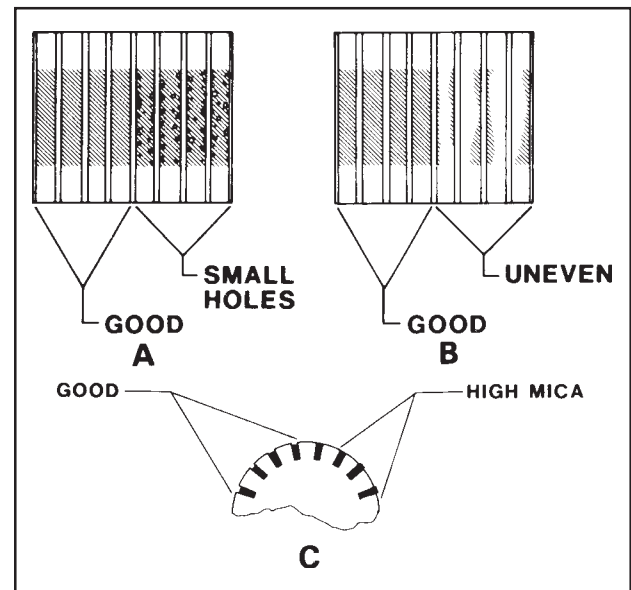
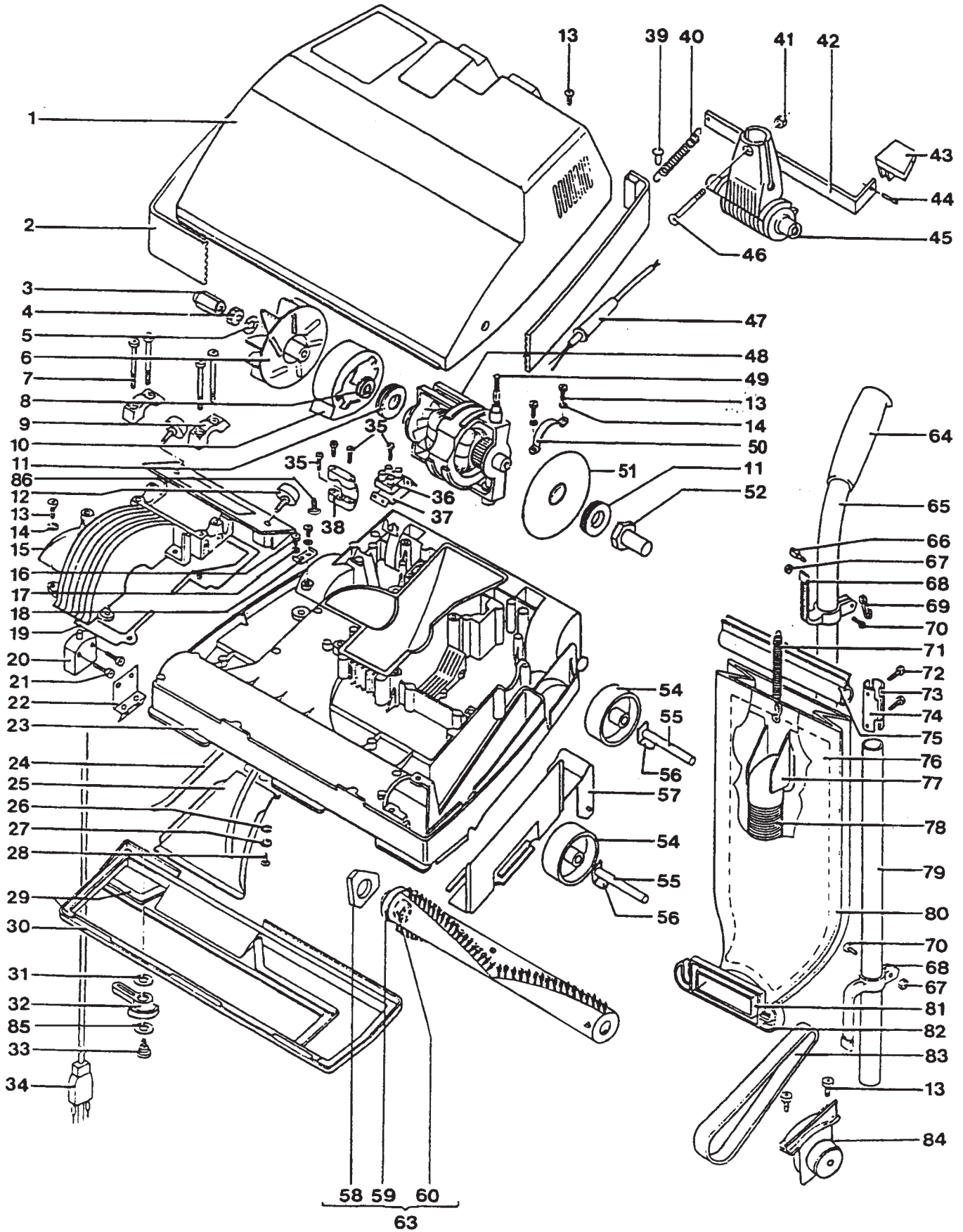

Figure 10

Clarke®
 Model 560B
 Assembly Drawing 1/07



Clarke®
Model 560B
Parts List 1/07

Ref. No.	Part No.	Description	No. Req'd.	Ref. No.	Part No.	Description	No. Req'd.
1	30037A	Cover	1	43	56807A	Foot Plate	1
2	51600A	Bumper	1	44	56810A	Roll Pin	1
3	920688	Nut, Plastic	1	45	56809B	Pivot, Handle	1
4	56205A	Nut, M7 Left	1	46	961022	Screw	1
5	87608A	Washer	1	47◆	40976A	Strain Relief	1
6	54711A	Impeller	1	48	44708B	Motor	1
7	964037	Screw	4	49	50295A	Carbon Brush	2
8◆	08351A	Washer	1	50	662005	Clamp	1
9	51910A	Clamp, Strap	2	51	53167A	Insulating Disc	1
10	52958A	Chamber, Fan	1	52	58327A	Shaft, Belt	1
11	57878A	Mount, Rubber	2	54	59905A	Wheel	4
12	961025	Screw, Wing	2	55	61697A	Axle	4
13	964007	Screw, 6 x 12	2	56	51924A	Clip, Locking	4
14	980607	Washer	8	57	52704A	Cover, Hinged	1
15	54801A	Housing, Blower	1	58	661507	Cap, Brush End	1
16	58008A	Screw, 4 x 8	2	59	663602	Thread, Guard	1
17	980603	Washer	2	60	902648	Bearing	2
18	667201	Retainer	1	63	53787A	Brush Assembly	1
19	54304A	Gasket	1	64	663703	Handle Grip	1
20	912311	Switch	1	65	663906	Handle Tube, Upp	1
21	964048	Screw, 4 x 18	2	66	664506	Cable Guide	1
22	664807	Insulation, Switch	1	67	924004	Nut M5	2
23	54802A	Plate, Bottom	1	68	664507	Cable Guide	1
24	54379A	Gasket	1	69	662104	Bag Clip	1
25	56806A	Plate, Sealing	1	70	964004	Screw, 5 x 16	2
26	53010A	Ring Retainer	1	71	668310	Spring	1
27	980933	Washer	1	72	964062	Screw, 8 x 25	2
28	961021	Screw	1	73	662411	Connector	1
29	54302A	Gasket	1	74	662412	Connector	1
30	666612	Nozzle Plate	1	75	662001	Dustbag Clip	1
31	980935	Washer Spring	2	76	660603	Paper Filter Bag	1
32	662004	Lever	2	77	662801	Elbow	1
33◆	08352A	Screw, M6 x 16 mm	2	78	664102	Hose	1
34	42217A	Power Cord	1	79	663909	Handle Tube Low	1
35	964006	Screw, 3 x 16	4	80	660609	Cloth Filter Bag	1
36	912313	Terminal Block	1	81	663409	Gasket	1
37	54701A	Insulation	1	82	660201	Adaptor	1
38	57318A	Strain Relief	1	83	903404	Belt	1
39	57303A	Rivet, Plastic	1	84	54803A	Housing Asm.	1
40	58601A	Spring	1	85◆	08353A	Spacer	2
41	924003	Nut M6	1	86◆	08354A	Screw, M3 x 13	1
42	56808A	Foot Pedal	1				

NOTE: ◆ indicates a change has been made since the last publication of this manual.



CAUTION: Repairs by qualified personnel only.
PRECAUTION: Reparations par personnel specialise seulement.
PRECAUTION: Unicamente personal calificado deberian hacer reparaciones.

CLARKE PRODUCT SUPPORT BRANCHES

U. S. A. Locations

PRODUCTION FACILITIES

Clarke®, Springdale, Arkansas
2100 Highway 265
Springdale, Arkansas 72764
(479) 750-1000
Customer Service - 1-800-253-0367
Technical Service - 1-800-356-7274

SERVICE FACILITIES

Clarke®, Elk Grove, Illinois 60007
2280 Elmhurst Road
(847) 956-7900

Clarke®, Denver, Colorado 80204
1955 West 13th Ave.
(303) 623-4367

Clarke®, Houston, Texas 77040
7215 North Gessner Road
713-937-7717

SERVICE AND SALES FACILITY

American Lincoln® / Clarke, Madison Heights,
Michigan 48071-0158
29815 John R.
(810) 544-6300

American Lincoln® / Clarke, Marietta, Georgia 30066
1455 Canton Road
(770) 973-5225

Clarke®

Clarke American Sanders

A.L. Cook

Customer Service Headquarters and Factory
2100 Highway 265
Springdale, Arkansas 72764
(479) 750-1000

Technical Service
1-800-356-7274

European Locations

PRODUCTION FACILITIES

ALTO Danmark A/S, Aalborg
Blytaekervej 2
DK-9000 Aalborg
+45 72 18 21 00

ALTO Danmark A/S, Hadsund
Industri kvarteret
DK-9560 Hadsund
+45 72 18 21 00

SALES SUBSIDIARIES

ALTO US - Canada, Ontario (Canada)
4080 B Sladeview Crescent Unit 1
Mississauga, Ontario L5L 5Y5
(905) 569 0266

ALTO Overseas Inc., Sydney (Australia)
1B/8 Resolution Drive
Caringbah NSW 2229
+61 2 9524 6122

ALTO Cleaning Systems Asia Pte Ltd., Singapore
No. 17 Link Road
Singapore 619034
+65 268 1006

ALTO Deutschland GmbH, Bellenberg (Germany)
Guido-Oberdorfer-Straße 2-8
89287 Bellenberg
+49 0180 5 37 37 37

ALTO Cleaning Systems (UK) Ltd., Penrith
Gilwilly Industrial Estate
Penrith
Cumbria CA11 9BN
+44 1768 868 995

ALTO France S.A. Strasbourg
B.P. 44, 4 Place d'Ostwald
F-67036 Strasbourg
Cedex 2
+33 3 8828 8400

ALTO Nederland B.V.
Postbus 65
3370 AB Hardinxveld-Giessendam
The Netherlands
+31 184 677 200

ALTO Sverige AB, Molndal (Sweden)
Aminogatan 18
Box 4029
S-431 04 Molndal
+46 31 706 73 00

ALTO Norge A/S, Oslo (Norway)
Bjornerudveien 24
N-1266
+47 2275 1770

Clarke® WARRANTY

This Clarke Technology Industrial/Commercial Floor Product is warranted to be free from defects in materials and workmanship under normal use and service for a period of one year from the date of purchase, when operated and maintained in accordance with Clarke Technology's Maintenance and Operations instructions.

This warranty is extended only to the original purchaser for use of the product. It does not cover normal wear parts such as electrical cable, rubber parts, hoses and motor brushes.

If difficulty develops with the product, you should:

- (a). Contact the nearest authorized Clarke Technology repair location or contact the Clarke Technology Service Operations Department, 2100 Highway 265, Springdale, Arkansas 72764, for the nearest authorized Clarke Technology repair location. Only these locations are authorized to make repairs to the product under this warranty.
- (b). Return the product to the nearest Clarke Technology repair location. Transportation charges to and from the repair location must be prepaid by the purchaser.
- (c). Clarke Technology will repair the product and or replace any defective parts without charge within a reasonable time after receipt of the product.

Clarke Technology's liability under this warranty is limited to repair of the product and/or replacement of parts and is given to purchaser in lieu of all other remedies, including INCIDENTAL AND CONSEQUENTIAL DAMAGES.

THERE ARE NO EXPRESS WARRANTIES OTHER THAN THOSE SPECIFIED HEREIN. THERE ARE NO WARRANTIES WHICH EXTEND BEYOND THE DESCRIPTION OF THE FACE HEREOF. NO WARRANTIES, INCLUDING BUT NOT LIMITED TO WARRANTY OF MERCHANTABILITY, SHALL BE IMPLIED. A warranty registration card is provided with your Clarke Technology product. Return the card to assist Clarke Technology in providing the performance you expect from your new floor machine.

Clarke, 2100 Highway 265, Springdale, Arkansas 72764.

Clarke reserves the right to make changes or improvements to its machine without notice.

Always use genuine Clarke parts for repair.

Clarke®

**CLARKE TECHNOLOGY
2100 Highway 265
Springdale, Arkansas, 72764**