

Eagle Power™ Products Group

450B AUTOMATIC SCRUBBER



ENTER 

PARTS MANUAL



Click on icon to return to this page.

← Back 1 page

450B Automatic Scrubber Code:PF02216US ac SN from 01A000

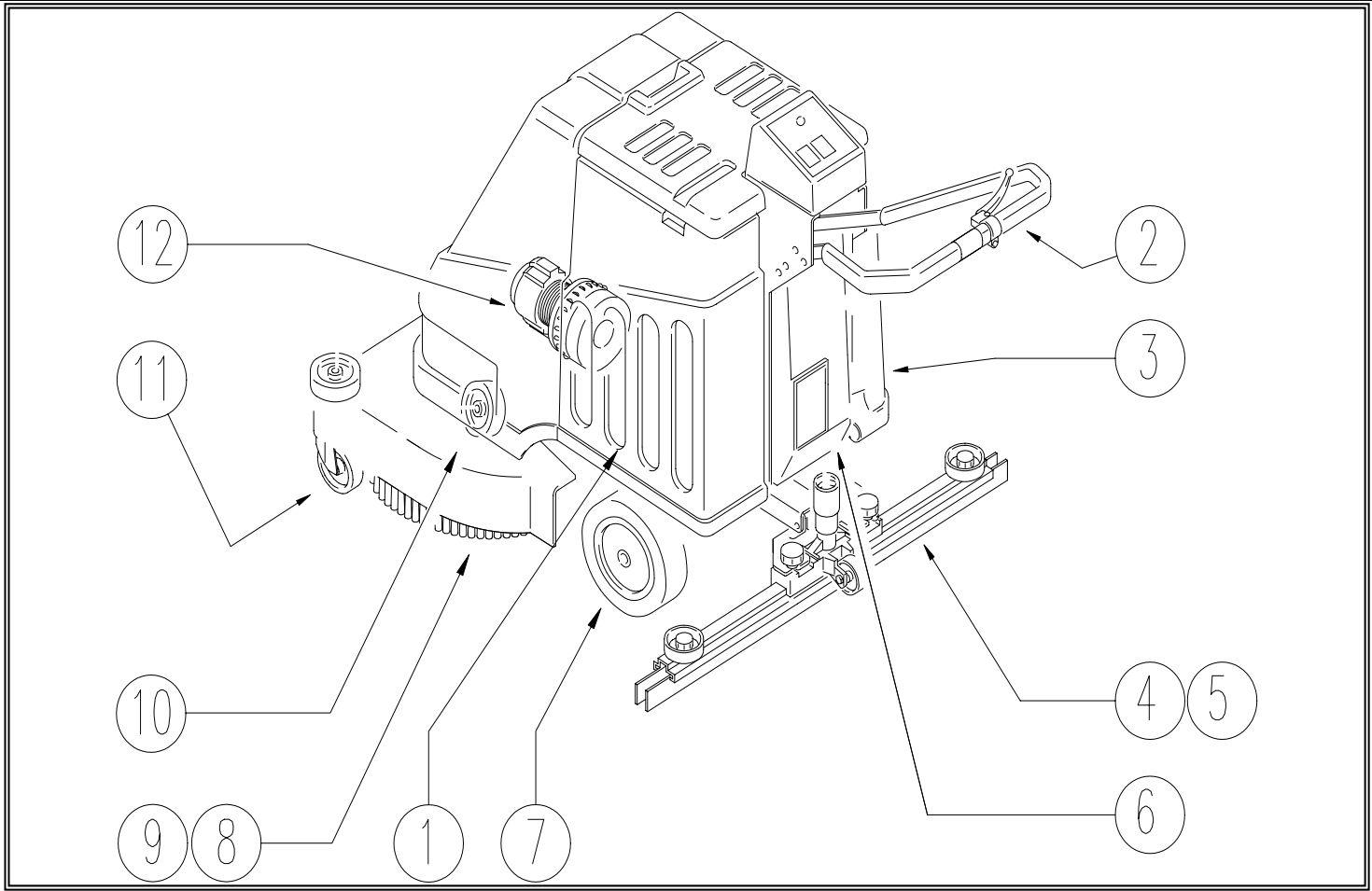

REF.	CODE	DESCRIPTION
1	PL1195	LEFT TANK
2	PL1197	HANDGRIP
3	PL1199	RIGHT TANK
4	PL1214	SQUEEGEE
5	PL1114	SQUEEGEE SUPPORT
6	PL1201	ELECTRIC UNIT
7	PL1202D	CHASSIS
8	PL1156	PULLEY AXLE
9	PL1161	ELECTRIC MOTOR
10	PL1163	PRESSURE WHEEL
11	PL1204BC	TRANSPORTING SMALL WHEEL
12	PL1154	SUCTION UNIT
/	PL1206	EXTERNAL PARTS
	WD27020	WIRING DIAGRAM
	EPF02216	LABELS - DOCUMENTS
	IPF02216	PACKING



← Back 1 page

450B Automatic Scrubber CODE: pl1195 ad SN from 01A000

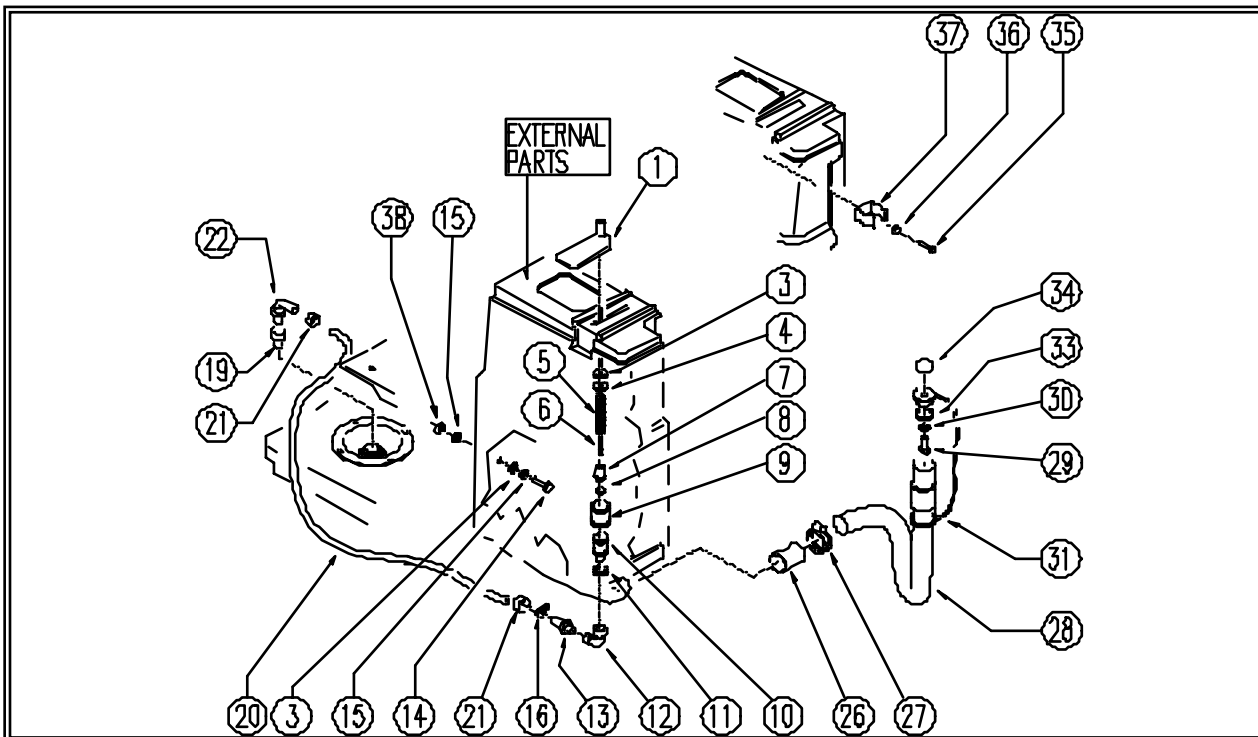

450B Automatic Scrubber CODE: pl1195 ad SN from 01A000

REF	CODE	DESCRIPTION	QTY
1	SL17140-1K	LEVER / CURSOR	1
3	SL03122	WASHER	2
4	SL06071	WASHER	1
5	SL13032	SPRING	1
6	SL09381	TIE ROD	1
7	SL07250	SHUTTER	1
8	SL03149	GASKET	1
9	SL18137	FILTER	1
10	SL07249	TAP	1
11	SL03058	GASKET	1
12	SL18130	UNION / CONNECTOR	1
13	SL18150	UNION / CONNECTOR	1
14	SL04145	SCREW	1
15	SL06025	WASHER	2
16	SL1415C	CLAMP	1
19	SL1825E	UNION / CONNECTOR	1
20	SL1924C	HOSE	1
21	SL14109	CLAMP	2
22	SL18232	UNION / CONNECTOR	1

Next page →



← Back 1 page

450B Automatic Scrubber CODE: pl1195 ad SN from 01A000			
REF	CODE	DESCRIPTION	QTY
26	SL0351€	SHEATH	1
27	SL14063	CLAMP	1
28	SL19113-	HOSE	1
29	SL04002	SCREW	1
30	SL06022	WASHER	1
31	SL14237	CAP	1
33	SL03315	GASKET	1
34	SL20015	KNOB (ø HANDWHEEL)	1
35	SL0417€	SCREW	2
36	SL0605€	WASHER	2
37	SL13014	DUCT LOCK	1
38	SL05039	NUT	1



450B Automatic Scrubber CODE: pl1197 ac SN from 01A000

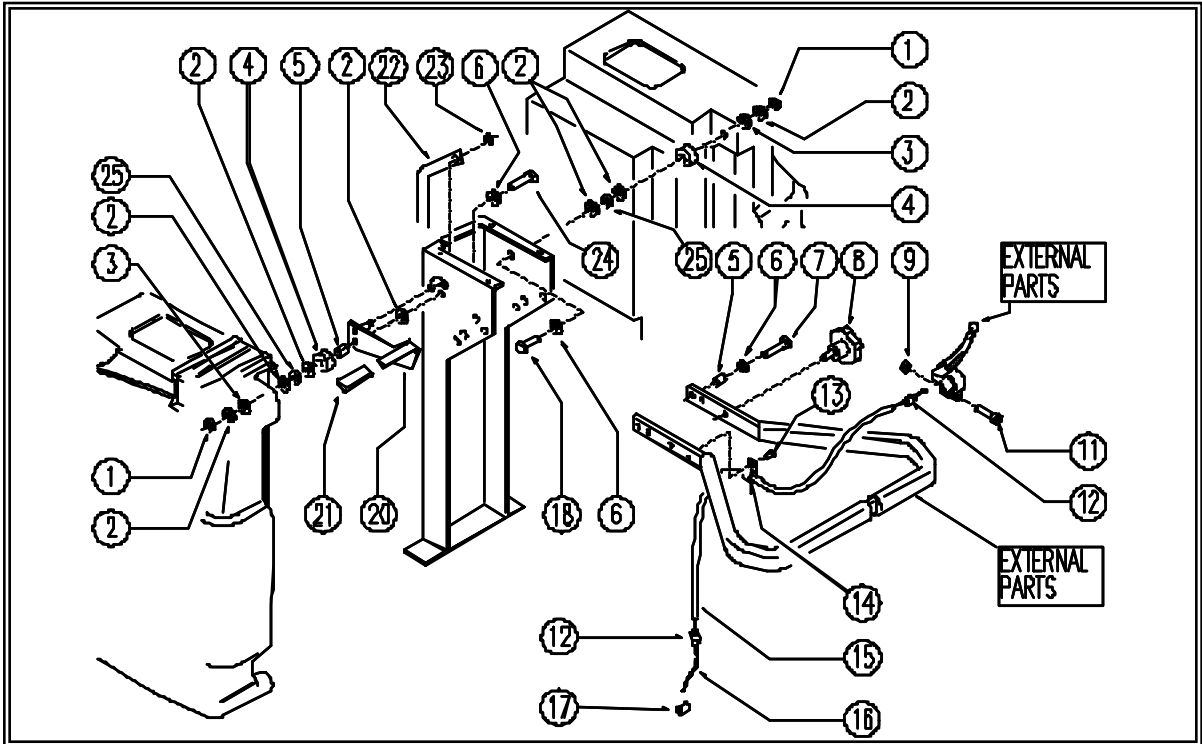

REF.	CODE	DESCRIPTION	QTY
1	SL05039	NUT	2
2	SL06025	WASHER	7
3	SL03122	WASHER	2
4	SL0720€	SPACER	2
5	SL07150	BUSHING	3
6	SL06041	WASHER	4
7	SL04203	SCREW	2
8	SL20012	HANDLE	2
9	SL05057	NUT	1
11	SL04063	SCREW	1
12	SL1411€	BUSHING	2
13	SL0407€	SCREW	1
14	SL1414€	EYELET	1
15	SL14100	SHEATH	1
16	SL1414€	CABLE	1
17	SL14141	CLAMP	1
18	SL04155	SCREW	1
20	SL09410k	LEVER	1
21	SL20021	HANDLE	1
22	SL09547	TIE-ROD	1
23	SL05041	RING	1



← Back 1 page

24	SL04164	SCREW	1
25	SL05001	NUT	2



450B Automatic Scrubber CODE: pl1199 ac SN from 01A000

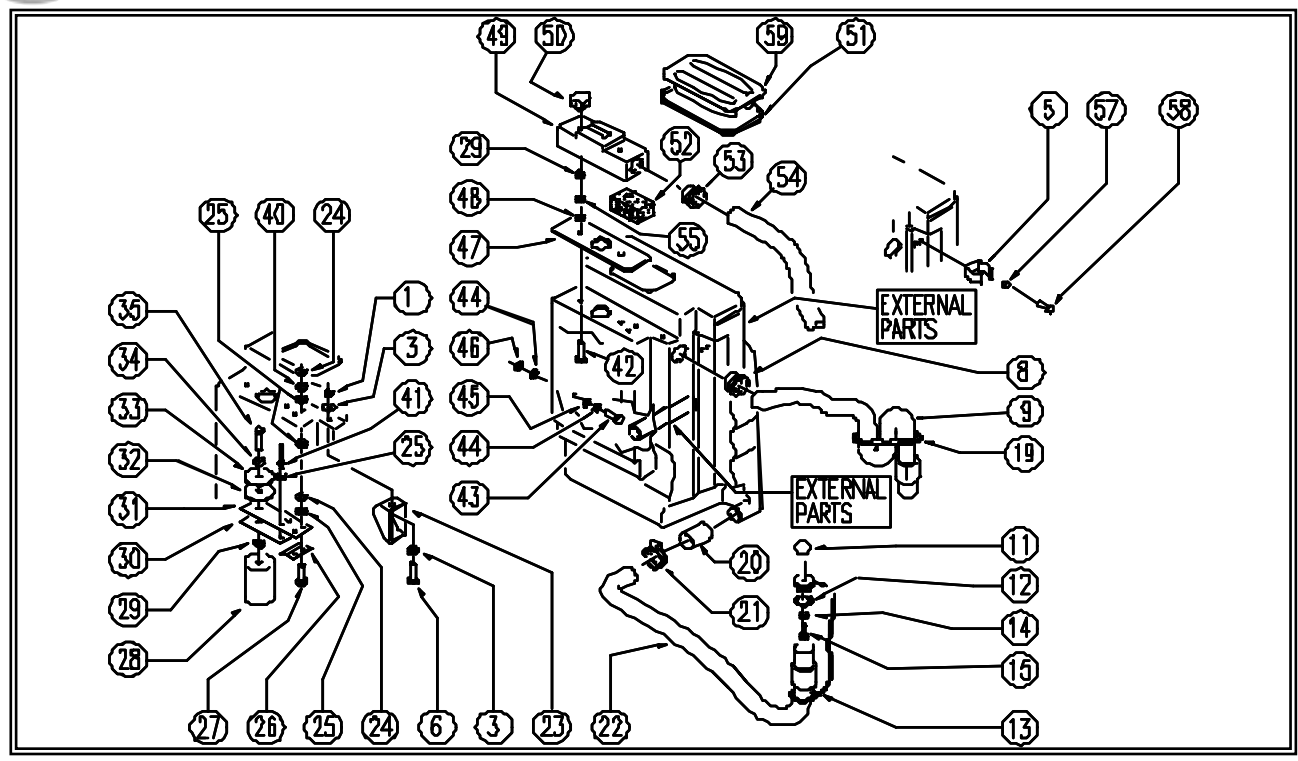

CODE: pl1199 ac SN from 01A000

REF	CODE	DESCRIPTION	QTY
1	SL05016	NUT	1
3	SL06034	WASHER	2
5	SL13014	DUCT LOCK	1
6	SL04152	SCREW	1
8	SL07178	BUSHING / BUSH	1
9	SL19113-2	HOSE	1
11	SL20015	KNOB (o HANDWHEEL)	1
12	SL03315	GASKET	1
13	SL14237	CAP	1
14	SL06022	WASHER	3
15	SL04002	SCREW	1
19	SL03437	PLAQUE	1
20	MP03196	SHEATH	1
21	SL14063	CLAMP	1
22	SL19113-1	HOSE	1
23	SL17155-1	BAFFLE PLATE	1
24	SL05044	NUT	4
25	SL06031	WASHER	8
26	SL09675	SMALL BRACKET	1
27	SL04189	SCREW	2
28	SL18065	FLOAT	1
29	SL05017	NUT	3
30	SL09364	PLATE	1
31	SL03111	RUBBER SHIM	1



← Back 1 page

CODE: pl1199 ac SN from 01A00C

REF	CODE	DESCRIPTION	QTY
32	SL03110	CAP	1
33	SL03235	CAP	1
34	SL06071	WASHER	1
35	SL04087	SCREW	1
40	SL06033	WASHER	2
41	SL14006	RIVET	2
42	SL04140	SCREW	2
43	SL04145	SCREW	1
44	SL06025	WASHER	1
45	SL03122	WASHER	2
46	SL05039	NUT	2
47	SL03113	GASKET	1
48	SL06071	WASHER	2
49	SL17141-1	BOX	1
50	SL20006	KNOB (o HANDWHEEL)	2
51	SL03470	GASKET	1
52	SL03109	FILTER	1
53	SL07044	BUSHING / BUSH	1
54	SL19100	HOSE	1
55	SL06023	WASHER	1
57	SL06056	WASHER	2
58	SL04213	SCREW	2
59	SL17552	LID	1



450B Automatic Scrubber CODE: pl1214 ab SN from 98E90

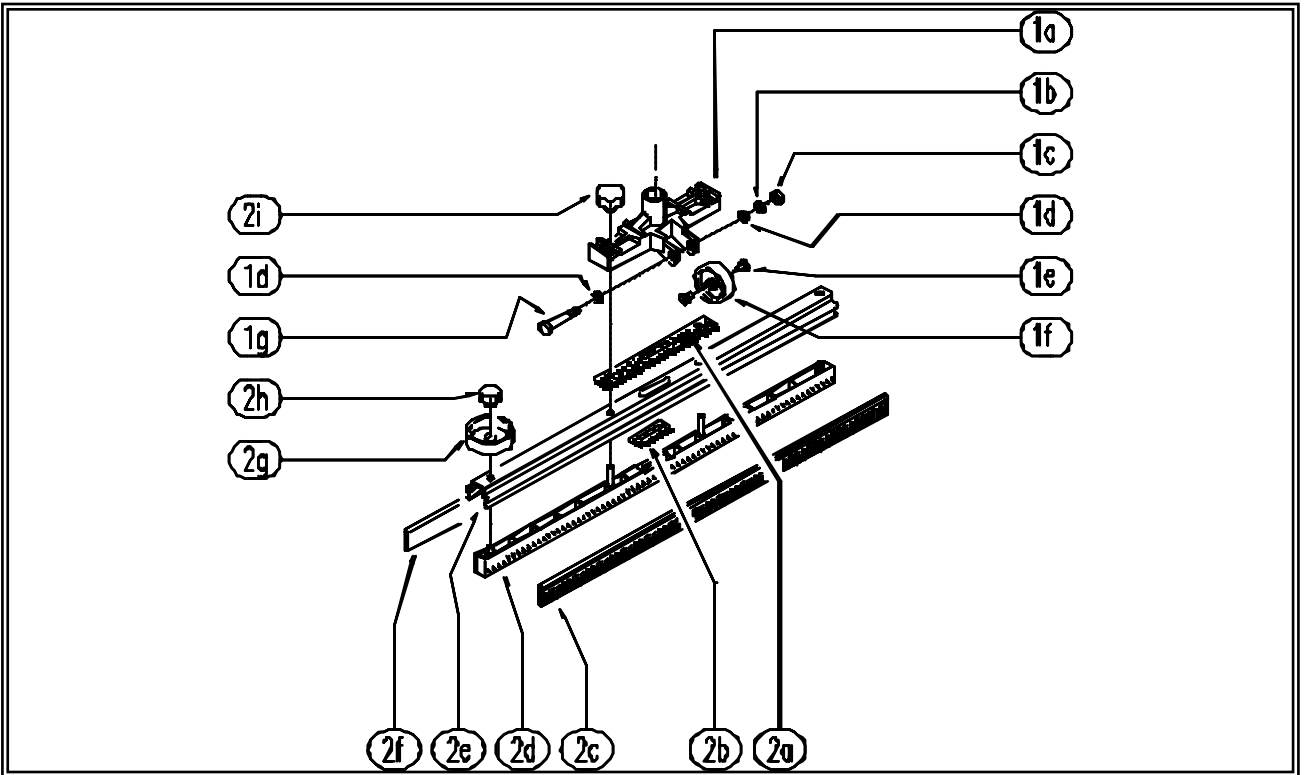

REF	CODE	DESCRIPTION
	SL03069	SQUEEGEE UNIT
1a	SL01018	SUCTION OPENING
1b	SL06023	WASHER
1c	SL05017	NUT
1d	SL06022	WASHER
1e	SL07077	BUSHING / BUSH
1f	SL08015	WHEEL / SMALL WHEEL
1g	SL04061	SCREW
2a	SL03051	GASKET
2b	SL03052	GASKET
2c	SL03047	BLADE
2d	SL15012	INSERT
2e	SL15015	EXTRUSION
2f	SL03233	BLADE
2g	SL08016	KNOB (o HANDWHEEL)
2h	SL20018	KNOB (o HANDWHEEL)
2i	SL20002	KNOB (o HANDWHEEL)



450B Automatic Scrubber Code: pl1114 ad SN from 98E9

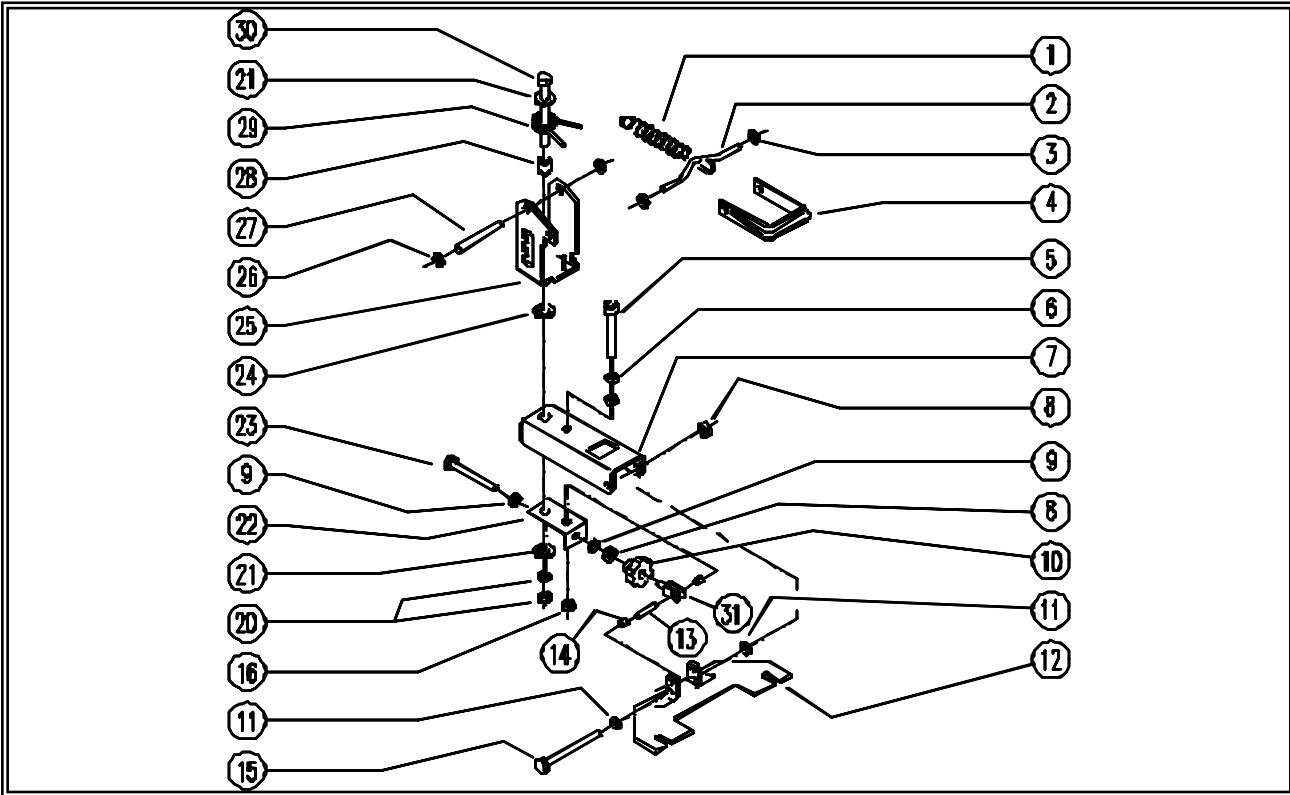

450B Automatic Scrubber Code: pl1114 ad SN from 98E908

REF	CODE	DESCRIPTION	QTY
1	SL13037	SPRING	1
2	SL09413	HOOKING	1
3	SL06060	RING	2
4	SL17180	HANDLE	1
5	SL04194	SCREW	1
6	SL05017	NUT	2
7	SL09516	ARM	1
8	SL05039	NUT	2
9	SL06041	WASHER	2
10	SL20020	HANDLE	1
11	SL06064	WASHER	2
12	SL09514	PLATE	1
13	SL11050	PIN	1
14	SL07141	SPACER	1
15	SL04229	SCREW	1
16	SL05041	NUT	1
20	SL05048	NUT	2
21	SL06025	WASHER	2



← Back 1 page

450B Automatic Scrubber Code: pl1114 ad SN from 98E908			
REF	CODE	DESCRIPTION	QTY
22	SL09513	SUPPORT	1
23	SL04156	SCREW	1
24	SL07138	WASHER	1
25	SL09515	BRACKET	1
26	SL05041	NUT	2
27	SL11039	PIN	1
28	SL07134	BUSH	1
29	SL13029	SPRING	1
30	SL04164	SCREW	1
31	SL22008	FORK	1



450B Automatic Scrubber CODE: pl1201 ab SN from 98E906

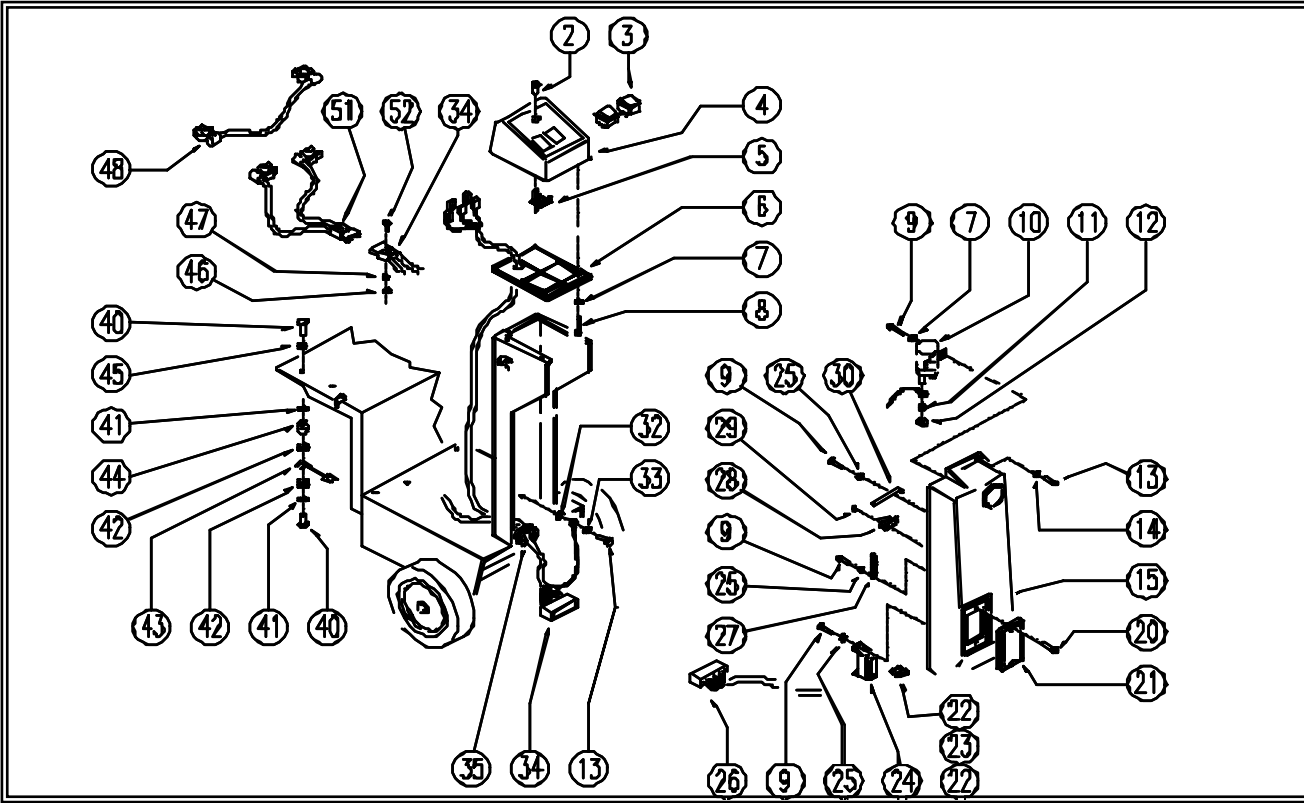

CODE: pl1201 ab SN from 98E906

REF.	CODE	DESCRIPTION
2	SL23031-	REFLECTOR
3	SL23183	SWITCH
4	SL17175	CONTROL PANEL
5	SL23031	GEARCASE / BOARD
6	SL17178	CONTROL PANEL BASE
7	SL06031	WASHER
8	SL04177	SCREW
9	SL04176	SCREW
10	SL23001	TELE-SWITCH
11	SL06002	WASHER
12	SL05004	NUT
13	SL04079	SCREW
14	SL06019	WASHER
15	SL17166	COVER
20	SL04027	SCREW
21	SL17149-	LID
22	SL23144	FUSE
23	SL23147	FUSE



← Back 1 page

CODE: pl1201 ab SN from 98E906

REF.	CODE	DESCRIPTION
24	SL23894-	CONNECTOR
25	SL06014	WASHER
26	SL2381E	WIRING
27	SL1302E	SPRING
28	SL23120	MICROSWITCH
29	SL04178	SCREW
30	SL0949E	FOIL / LAMINA
32	SL06033	WASHER
33	SL06032	WASHER
34	SL23817K	WIRING
35	SL2311E	FAIRLEAD
40	SL04092	SCREW
41	SL06001	WASHER
42	SL06015	WASHER
43	SL23837	FUSE
44	SL23842	FUSE
45	SL06004	WASHER
46	SL05009	NUT
47	SL06024	WASHER
48	SL23838	BRIDGE
51	SL23839US	WIRING
52	SL04122	SCREW



450B Automatic Scrubber CODE: pl1202D ab SN from 00A500

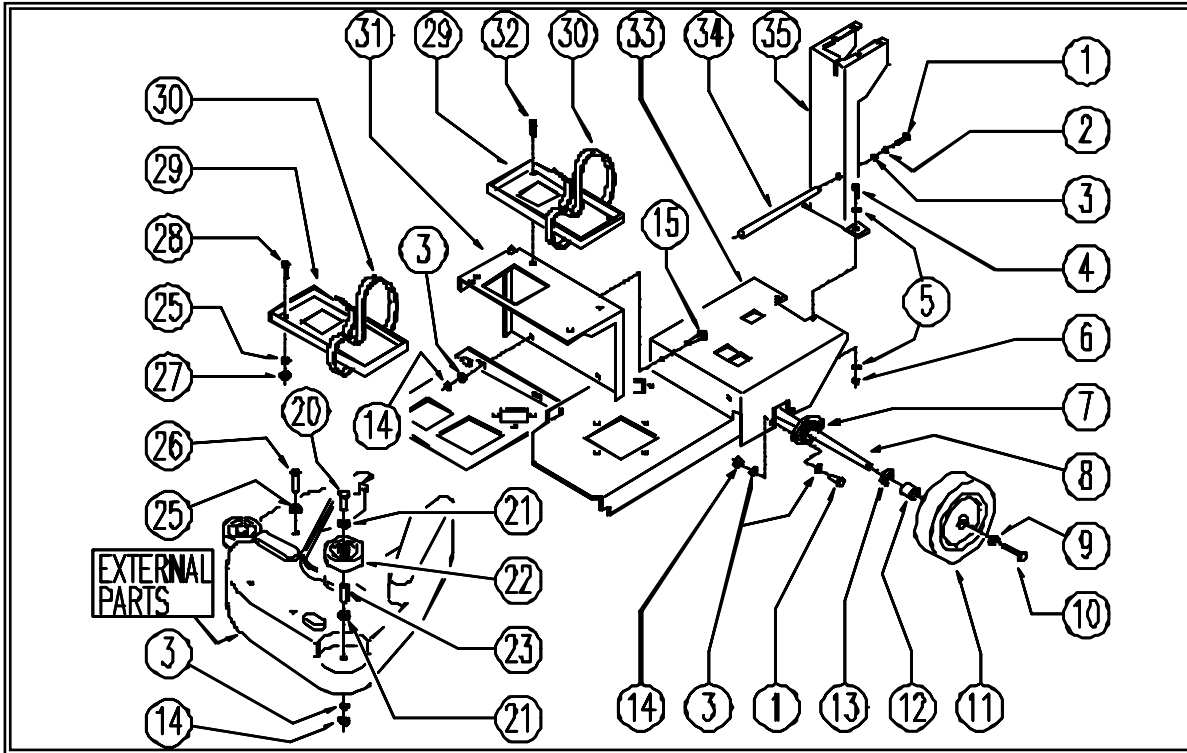

450B Automatic Scrubber CODE: pl1202D ab SN from 00A500

REF	CODICE	DESCRIPTION
1	SL0404E	SCREW
2	SL06023	WASHER
3	SL06022	WASHER
4	SL04145	SCREW
5	SL06003	WASHER
6	SL0503E	NUT
7	SL12022	SUPPORT
8	SL07140	AXLE
9	SL06025	WASHER
10	SL04077	SCREW
11	SL08022	WHEEL
12	SL07211	BEARING
13	SL0605E	WASHER
14	SL05041	NUT
15	SL04216	SCREW
20	SL04133	SCREW
21	SL0603E	WASHER
22	SL08015	WHEEL



← Back 1 page

450B Automatic Scrubber CODE: p11202D ab SN from 00A500

REF	CODICE	DESCRIPTION
23	SL07165	BEARING
25	SL06038	WASHER
26	SL04065	SCREW
27	SL05043	NUT
28	SL04017	SCREW
29	SL17238	PLATE
30	SL14096	BELT
31	SL09587D	SUPPORT
32	SL04095	SCREW
33	SL09651	BASEMENT
34	SL09349	BEARING
35	SL09585	UPRIGHT / PILLAR



450B Automatic Scrubber CODE: pl1156 ab SN from 99J10

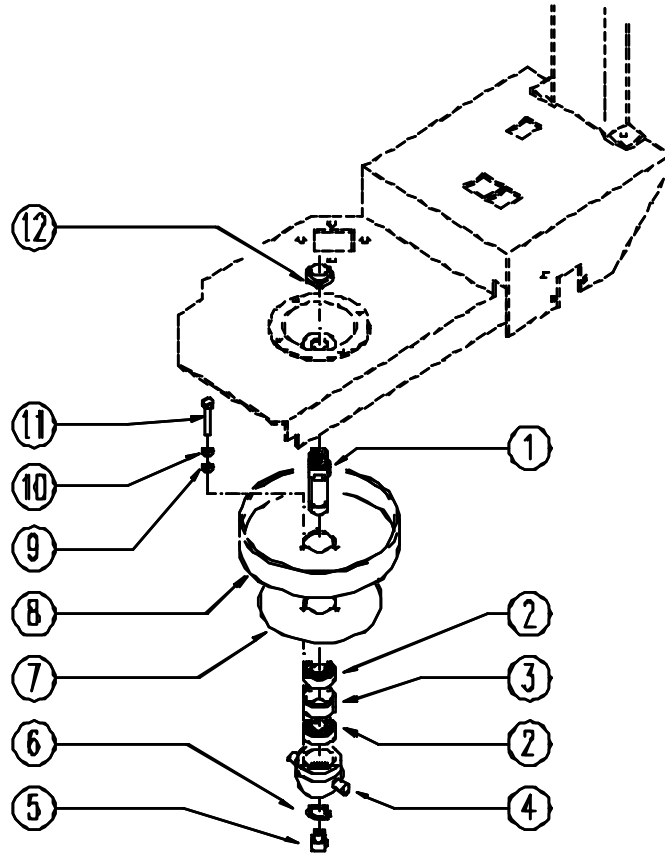

REF.	CODE	DESCRIPTION
1	SL07303	PIN
2	SL12025	BEARING
3	SL07161	BEARING
4	SL01023	CONVEYOR, DRIVER
5	SL17163	CAP
6	SL11096	SHAFT
7	SL03511	DISC
8	SL10047	PULLEY
9	SL06023	WASHER
10	SL06022	WASHER
11	SL04135	SCREW
12	SL05049	NUT



← Back 1 page

450B Automatic Scrubber CODE: pl1161 ab SN from 01A000

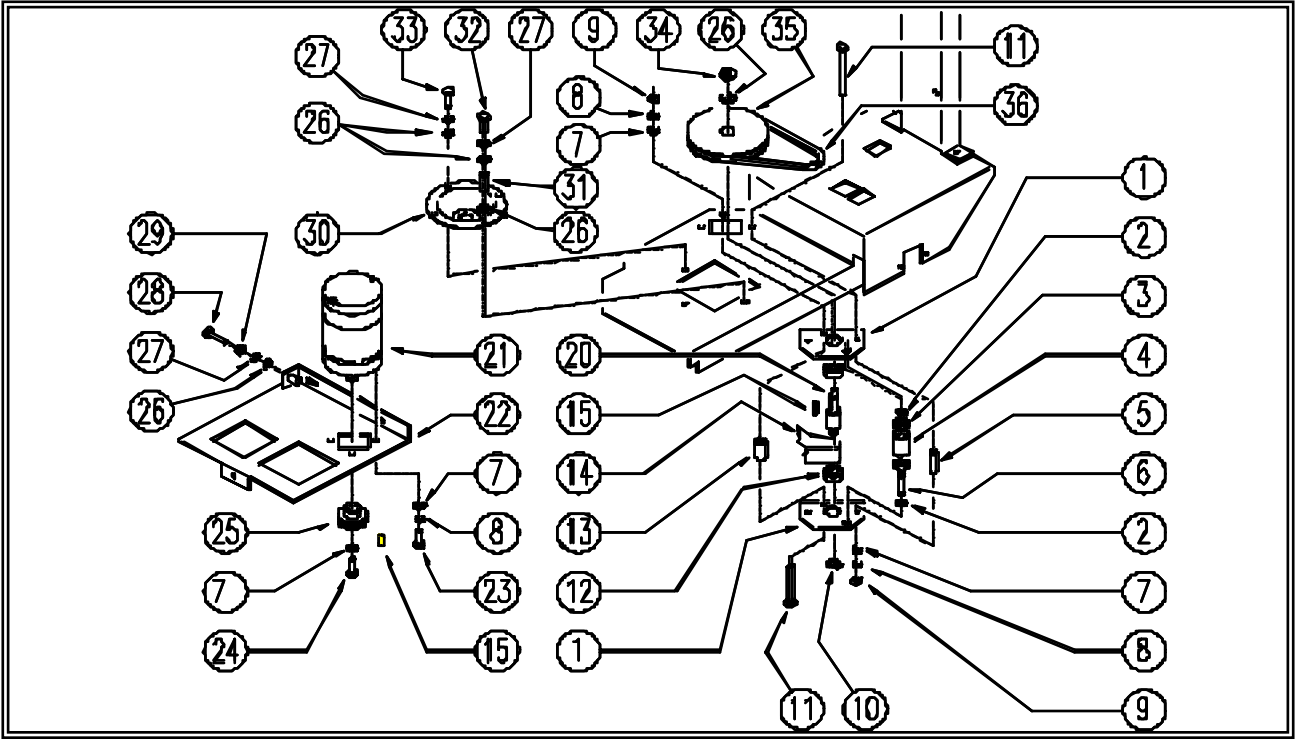

450B Automatic Scrubber CODE: pl1161 ab SN from 01A000

REF	CODE	DESCRIPTION
1	SL0959z	PLAQUE
2	SL11095	RING
3	SL12003	BEARING
4	SL10045	PULLEY
5	SL07143	BEARING
6	SL11041	PIN / PLUG
7	SL06022	WASHER
8	SL06023	WASHER
9	SL05017	NUT
10	SL11100	RING
11	SL04061	SCREW
12	SL12029	BEARING
13	SL07191	BEARING
14	SL16016	BELT
15	SL1101c	TANG / TONGUE
20	SL07190	SHAFT
21	SL02099	MOTOR
22	SL0958e	SUPPORT
23	SL04135	SCREW
24	SL04135	SCREW

Next page →



← Back 1 page

450B Automatic Scrubber CODE: pl1161 ab SN from 01A000

REF	CODE	DESCRIPTION
25	SL10049	PULLEY
26	SL06041	WASHER
27	SL06057	WASHER
28	SL04156	SCREW
29	SL05048	NUT
30	SL15023	FLANGE
31	SL07196	BEARING
32	SL04143	SCREW
33	SL04134	SCREW
34	SL05039	NUT
35	SL10048	PULLEY
36	SL16018	BELT



450B Automatic Scrubber CODE: pl1163 aa SN from 98E905

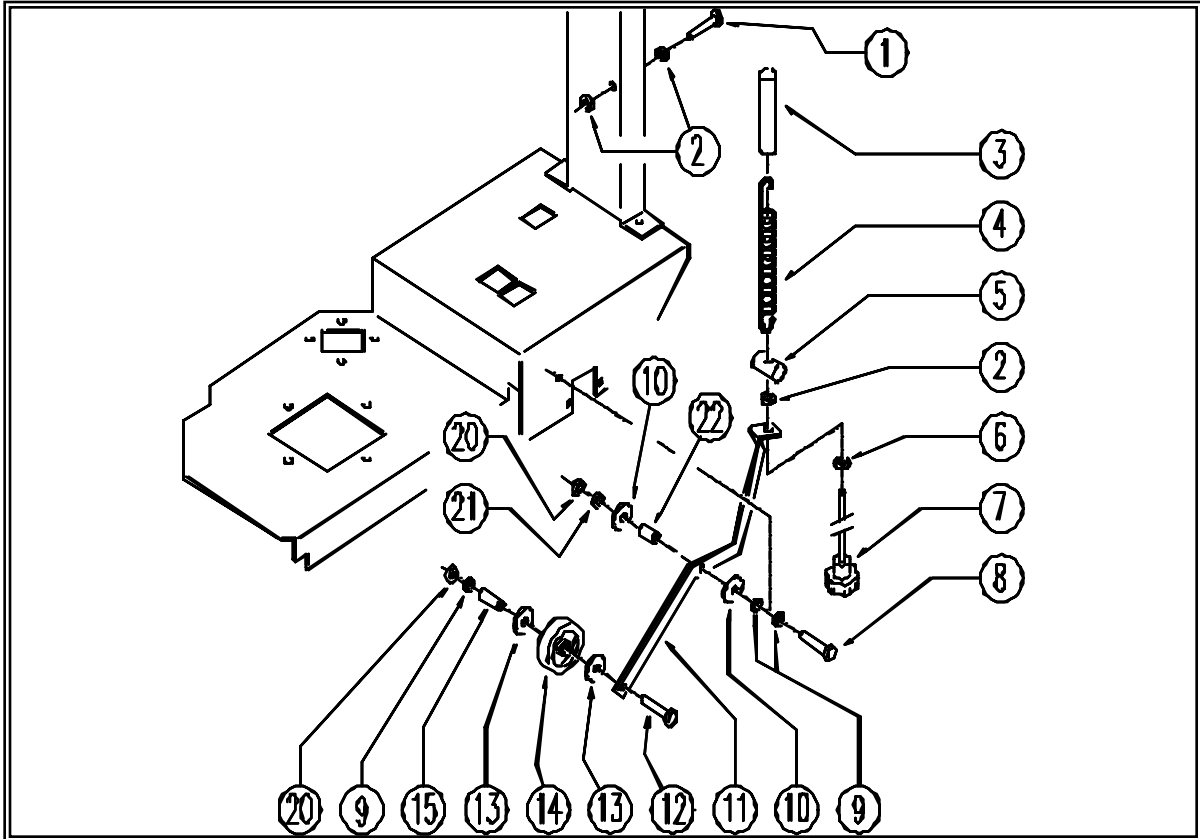

REF	CODE	DESCRIPTION	QTY
1	SL04048	SCREW	1
2	SL05017	NUT	3
3	MP19201	SHEATH	1
4	SL13037	SPRING	1
5	SL07199	SPRING COUPLING	1
6	SL06039	WASHER	1
7	SL20047	KNOB (ø HANDWHEEL)	1
8	SL04127	SCREW	1
9	SL06041	WASHER	3
10	SL06053	WASHER	2
11	SL0958C	LEVER	1
12	SL04156	SCREW	1
13	SL08024-1	WASHER	2
14	SL08024-3	WHEEL / SMALL WHEEL	1
15	SL08024-2	PIN	1
20	SL05039	NUT	2
21	SL05048	NUT	1
22	SL07063	BUSHING / BUSH	1



← Back 1 page

450B Automatic Scrubber Code: pl1204BC aa SN from 98L000

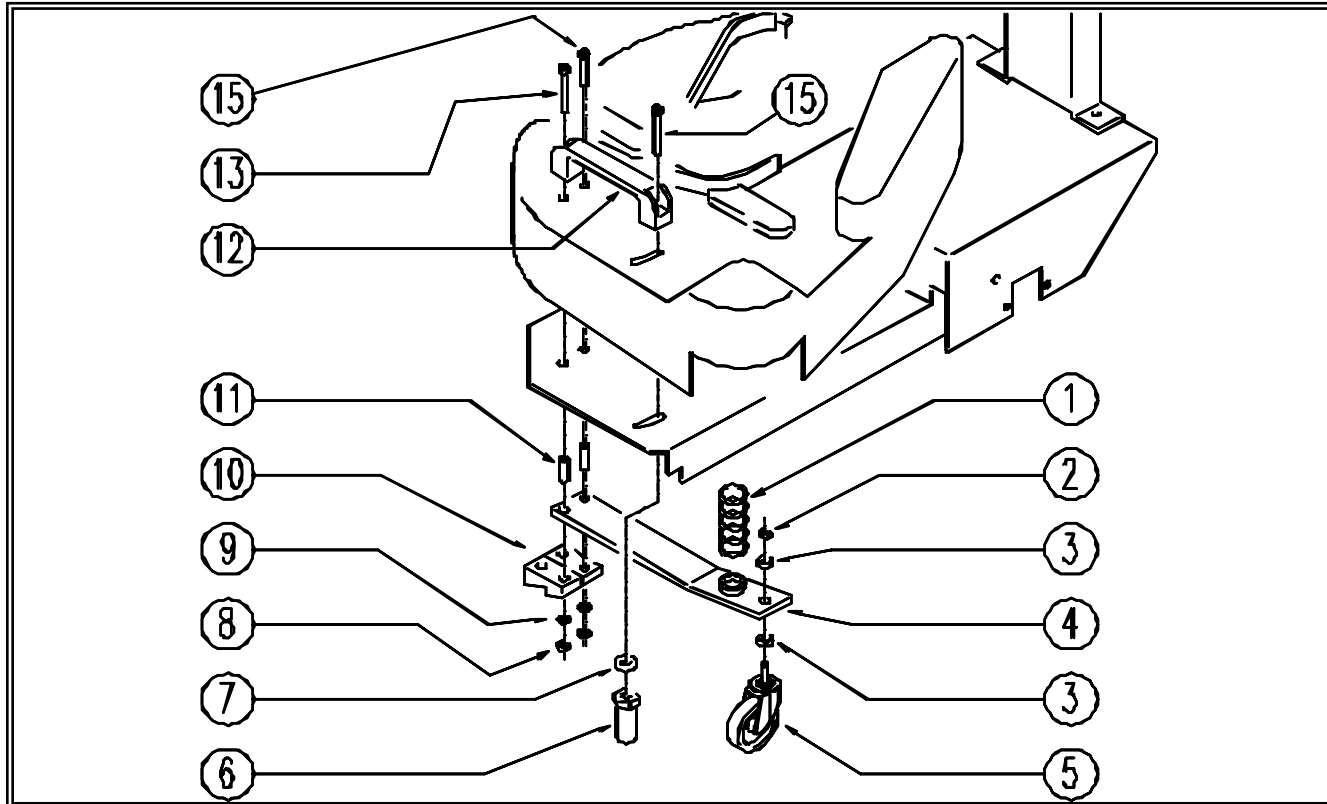

REF	CODE	DESCRIPTION
1	SL13069	SPRING
2	SL05013	NUT
3	SL06005	WASHER
4	SL09953	LEVER
5	SL08029	WHEEL / SMALL WHEEL
6	SL07248	BEARING
7	SL06073	WASHER
8	SL05039	NUT
9	SL06025	WASHER
10	SL03121	SILENT BLOK
11	SL07241	BEARING
12	SL20029	HANDLE
13	SL04237	SCREW
15	SL04238	SCREW



Back 1 page

450B Automatic Scrubber CODE: pl1154 aa SN from 98E9

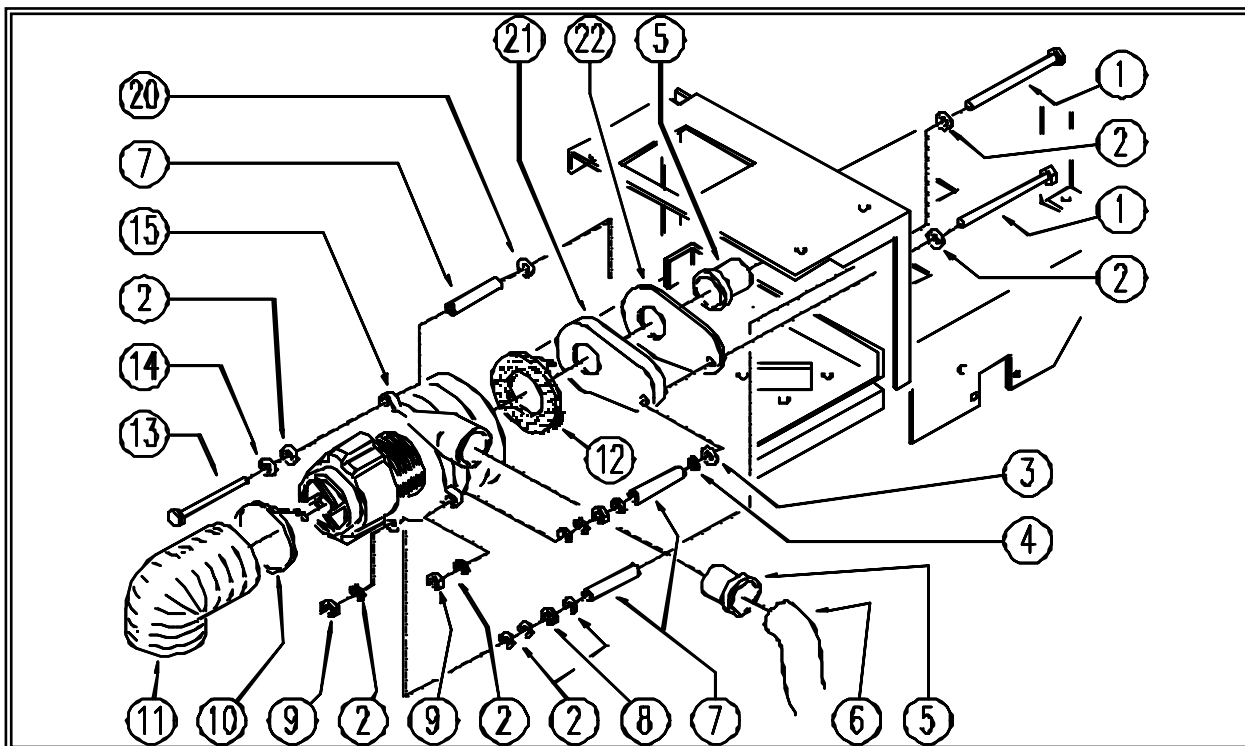

REF	CODE	DESCRIPTION
1	SL04282	SCREW
2	SL06022	WASHER
3	SL06030	WASHER
4	SL11095	RING
5	SL07044	BUSHING / BUSH
6	SL19113	HOSE
7	SL07290	BEARING
8	SL05017	NUT
9	SL05041	NUT
10	SL14020	CLAMP
11	SL19157	HOSE
12	SL03033	GASKET
13	SL04247	SCREW
14	SL06023	WASHER
15	MP02302-J	MOTOR
20	SL06041	WASHER
21	SL17239	SUCTION CONVEYOR
22	SL03160	GASKET



← Back 1 page

450B Automatic Scrubber CODE: pl1206 ac SN from 01A000

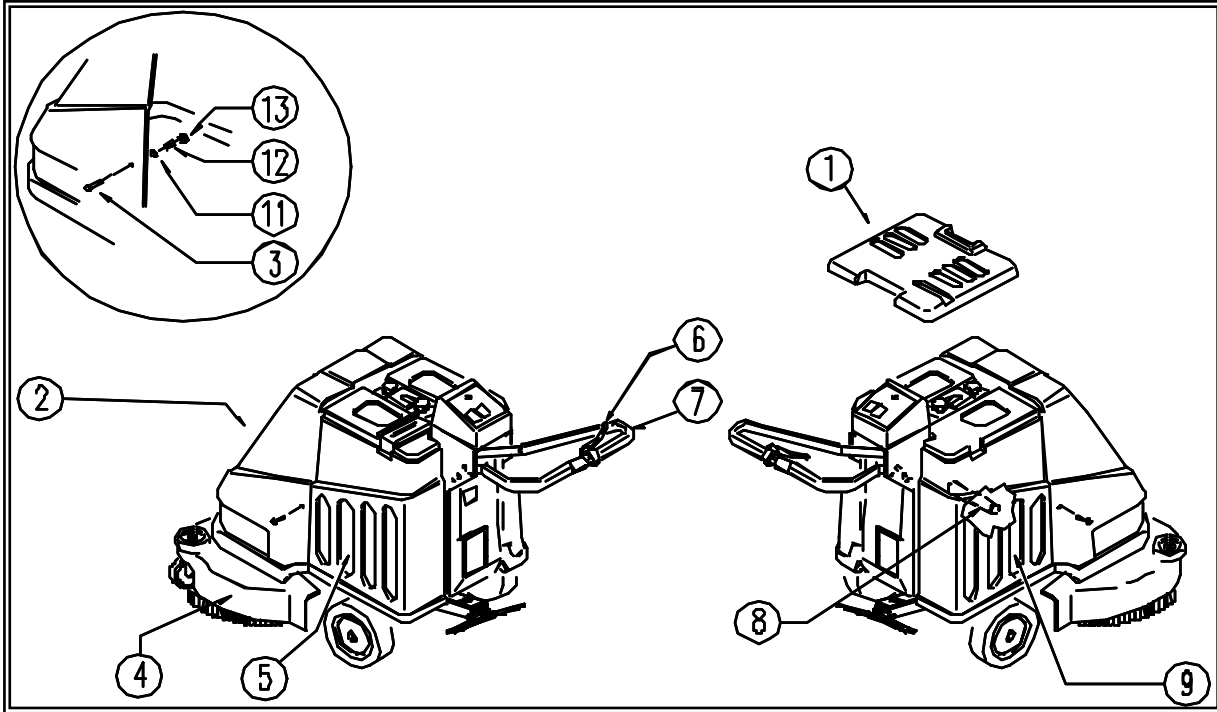

REF	CODE	DESCRIPTION	QTY
1	SL17605NE	LID	1
2	SL17242	HOOD	1
3	SL04161	SCREW	2
4	SL17320-	BRUSH COVER	1
5	SL17136F	TANK	1
6	SL20019	LEVER	1
7	SL09343	HANDGRIP	1
8	SL0720E	CROSS	1
9	SL17230PF	TANK	1
11	SL13054	WASHER	2
12	SL07169	SPACER	2
13	SL0721C	BUSHING / BUSH	2



450 AUTOMATIC SCRUBBER

CODE:

wd27020 aa SN from 98E905

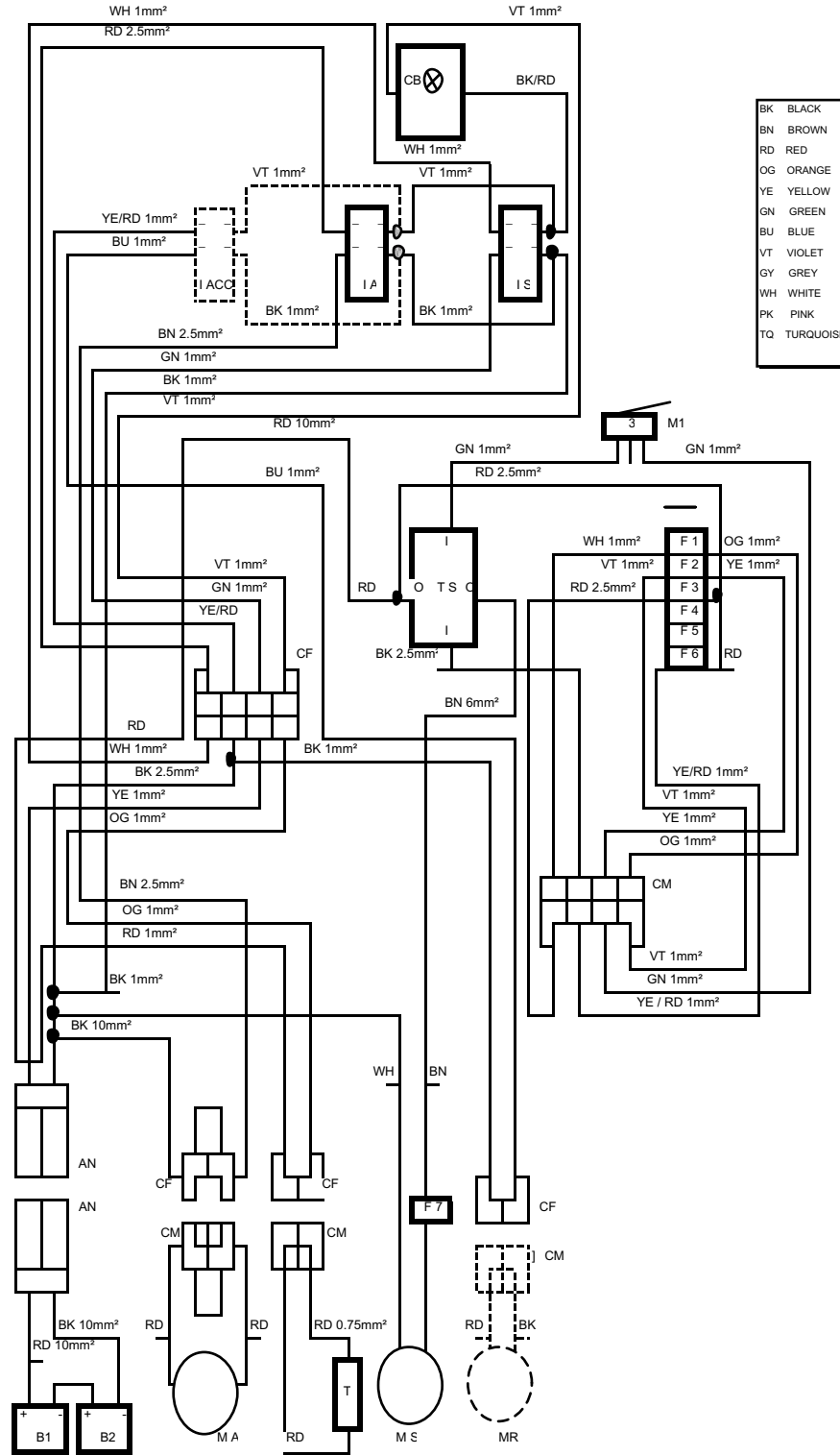

REFCODE DESCRIPTION

IA	VACUUM SWITCH
IACC	COMBI SWITCH
IS	BRUSH SWITCH
CB	BATTERY CONTR.
M1	BRUSH MICROSWI

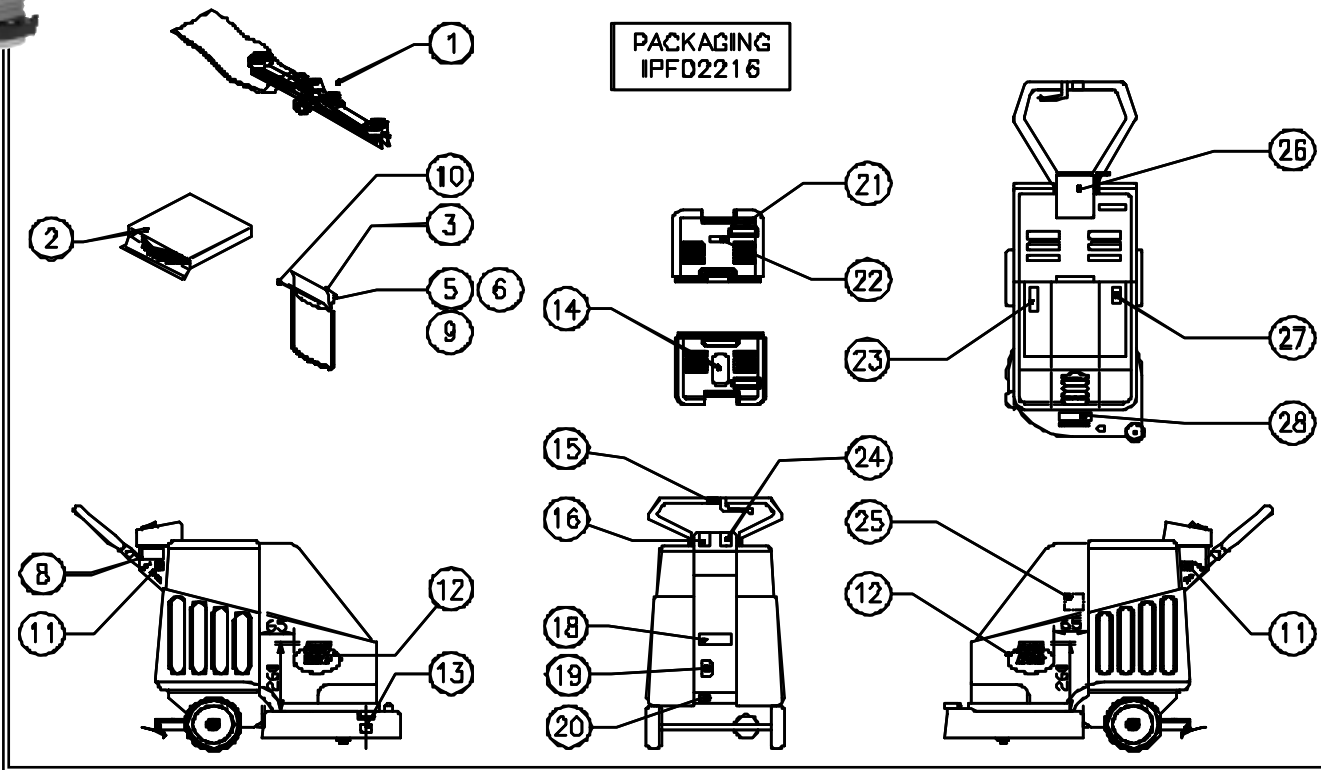

REF	CODE	DESCRIPTION
1	SL03069	SQUEEGEE
2	AL02251	BRUSH
3	SL25189N-1	OPERATOR'S MANUAL
5	SL25401-2	LABEL - DOCUMENT
6	SL25401-3	LABEL - DOCUMENT
8	SL25401-6	LABEL - DOCUMENT
9	SL25401-8	LABEL - DOCUMENT
10	SL25303	LABEL
11	SL25002	LABEL
12	SL25956	LABEL
13	SL25472	LABEL
14	SL25056	LABEL
15	SL25006C	LABEL
16	SL25176	LABEL
18	SL25177	LABEL
19	SL25187	LABEL
20	SL25288	LABEL
21	SL25474	LABEL
22	SL25473	LABEL
23	SL25257US	LABEL
24	SL25362	LABEL
25	SL25030	LABEL
26	SL25232N	LABEL
27	SL25251	LABEL
28	SL25468	LABEL



450B Automatic Scrubber CODE: IPF02216 aa SN from 01A000

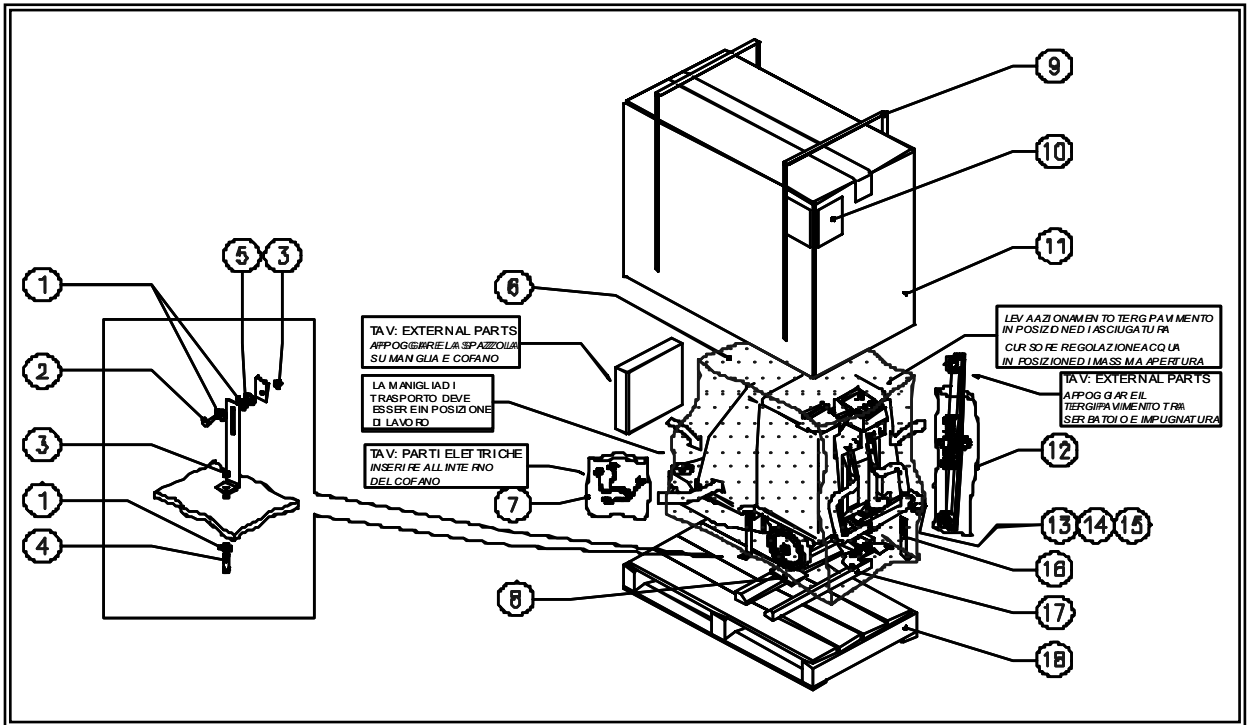

REF	CODE	DESCRIPTION
1	SL06017	WASHER
2	SL04004	SCREW
3	SL05001	NUT
4	SL04001	SCREW
5	SL03122	WASHER
6	SL26083	NYLON
7	GR26020US	ENVELOPE
8	SL26069	CARDBOARD
9	MP14300	STRAP
10	SL25401-1	LABEL
11	SL26009N	CARDBOARD
12	SL14302	NYLON
13	SL26029	ENVELOPE
14	SL20012	KNOB (o HANDWHEEL)
15	SL23010K	ANDERSON
16	SL09241	BRACKET
17	SL26018	LATH / SPLINE
18	SL26008	PALLET



Warranty Policy

Limited Warranty

Eagle Power Products (EPP) warrants new cleaning equipment against defects in material and workmanship under normal use and service to the original purchaser as detailed below.

10 Years

Subject to the conditions stated below, EPP warrants polyethylene tanks and housings to be free from defects in materials and workmanship for a period of ten years.

3 Years

Subject to the conditions stated below, EPP warrants all automatic scrubber components to be free from defects in materials and workmanship for a 3-year period. Parts replaced or repaired are warranted for the remainder of the original warranty period.

1 Year

Subject to the conditions stated below, EPP warrants all other cleaning equipment components to be free from defects in materials and workmanship for a 1-year period. Parts replaced or repaired are warranted for the remainder of the original warranty period. Batteries are prorated for one year.

EPP will furnish and charge for replacement parts, including transportation, to the original owner through an EPP authorized service center. If the part is returned within 30 days and is found defective, the owner will be credited for the cost of the replacement part including shipping and handling.

Labor charges are covered for one year from the date of purchase if provided by an authorized EPP service center. Travel is covered for 90 days for battery operated equipment only.

Wear items exempt from warranty include belts, carbon brushes, power cords, wheels, pad drivers, clutch plates, brushes, pads, handle grips, filters, screens, throttle cables, and squeegees.

This warranty shall not apply to failures caused by misuse or abuse, improper maintenance as stated in the operation manuals, use of unauthorized repair parts, repairs by other than an EPP authorized service center, and damage in transit.

EPP disclaims and denies any liability for any direct, indirect, special incidental or consequential damage which may be suffered as a result of sale, delivery, servicing, use, loss of any product, downtime, labor, freight, or other charges not expressly included herein.

Date Purchased: _____

Serial Number: _____

Serial Number: _____

Please be sure to record this information. This information will be necessary for future warranty claims.



1174 Northland Drive Mendota Heights, MN 55120
651.686.5399 Fax 651.686.5695
www.eaglepower.com

Eagle Power Products Sales and Service Provided by: