

# Safety, Operation Manual & Parts List

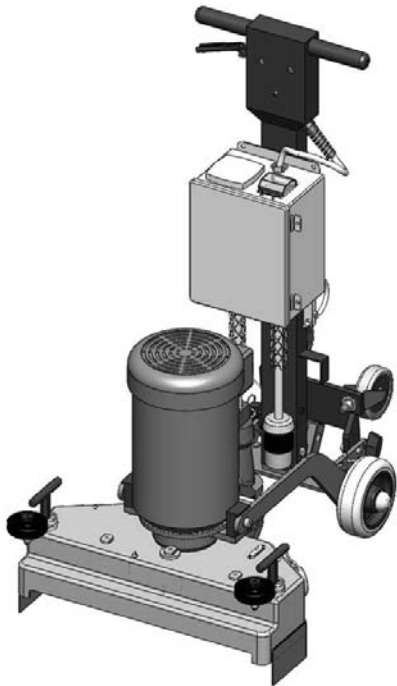

## EDGE MP

HIGH PERFORMANCE EDGER

Concrete Grinding Machine  
This unit is intended for commercial use.

Read & Follow All Instructions, Warnings  
& Cautions Before Using This Machine

## Please Read Carefully Before Operating

This machine will afford you many years of trouble free operating satisfaction if it is given proper care. All parts have passed rigid quality control standards before being assembled to produce the finished product. Prior to packaging, the units are again inspected for assurance of flawless assembly.

This machine is protectively packed to prevent damage in shipment. Upon delivery, we recommend removing the unit from its carton and carefully inspecting it for any possible damage in transit. A warranty card is affixed to the handle. It is your responsibility to fill it out and send it to our office to register your purchase and start your warranty. Failure to send us this card within one week upon receipt of the machine may void the warranty.

If damage is discovered, immediately notify the transportation company that delivered your machine. As a shipper, we are unable to act upon any claim for concealed damage. You must originate any claim within 5 days of delivery.

This manual is for your protection and information. **PLEASE READ CAREFULLY!** Failure to follow these precautions could result in injury or discomfort.

Treat this machine as you would any other high grade precision made product. Throwing, dropping, unreasonable bumping across thresholds and other misuse may result in a damaged unit and invalidate the warranty.

Save These Instructions

# Important Safety Instructions



## **WARNING:**

To reduce the risk of fire, electric shock, or injury; read all instructions before using this machine. When using this machine, basic precautions should always be followed, including the following.

- 1) DO NOT leave the floor machine plugged in when not in use. Unplug from the outlet when not in use and/or before servicing.
- 2) Electric shock could occur if exposed to rain. Store indoors.
- 3) This is NOT a toy. Close attention is necessary when used around or near children.
- 4) Use only as described in this manual. Use only manufacturer's recommended attachments.
- 5) DO NOT use with a damaged cord plug.
- 6) If the floor machine is not working as it should because it has been dropped, damaged, left outdoors, or dropped into water, contact the manufacturer or an authorized service center.
- 7) DO NOT handle the plug or operate with wet hands.
- 8) DO NOT pull or carry by cord, use power cord as a handle, close a door on cord, or pull cord around sharp edges or corners. DO NOT run floor machine over the cord. Keep cord away from heated surfaces.
- 9) DO NOT unplug by pulling on cord. To unplug, grasp plug, not the power cord.
- 10) DO NOT put any object into motor openings.
- 11) Keep hair, loose clothing, jewelry, fingers and all other parts of body away from moving components.
- 12) DO NOT use an optional vacuum without the manufacturer's filters in place.
- 13) DO NOT operate where anesthetics and oxygen are used.
- 14) DO NOT use an extension cord.
- 15) DO NOT use around flammable or combustible liquids such as gasoline or use in areas where they may be present.
- 16) Replace damaged or worn parts immediately with genuine Grind 'N Go equipment parts to maintain safety and protect your limited warranty.
- 17) Floor sanding can result in an explosive mixture of fine dust and air. Use a floor sanding machine only in a well ventilated area.
- 18) This floor machine must be connected to a properly grounded outlet only. (See Grounding Methods, Page 3.)

# Grounding Safety Instructions



## **DANGER:**

Improper use of the grounding plug can result in a risk of electrical shock.

This floor machine must be grounded. If it should malfunction or breakdown, grounding provides a path of least resistance for electrical current thus, reducing the risk of electric shock. This machine is equipped with an equipment-grounded plug. The plug must be inserted into an appropriate outlet that is properly installed and grounded in accordance with all local codes and ordinances.

If repair or replacement of the cord or plug is necessary, DO NOT connect the grounding wire to either flat blade terminal. The insulated wire with an outer surface that is green with or without yellow stripes is the grounding wire.

## Grounding Methods



## **WARNING:**

Improper connection of the equipment-grounding conductor can result in a risk of electrical shock. Check with a qualified electrician or service person if you are in doubt as to whether the outlet is properly grounded. DO NOT modify the plug provided with the machine. If it will not fit the outlet, have a proper outlet installed by a qualified electrician.

NOTE: In Canada, use of a temporary adaptor is not permitted by the Canadian Electrical Code.

This grinding machine has a grounding plug that looks like the plug illustrated in (Fig A). A temporary adaptor that looks like the adaptor illustrated in (Fig B & C) may be used to connect the plug to a 2-pole receptacle as shown in (Fig A) if a properly grounded outlet is not available.

The temporary adaptor should be used only until a properly grounded outlet (Fig A) can be installed by a qualified electrician. The green color rigid ear, lug, or like extending from the adaptor must be connected to a permanent ground such as a properly grounded outlet box cover. Whenever the adaptor is used, it must be held in place by a metal screw (Fig C).

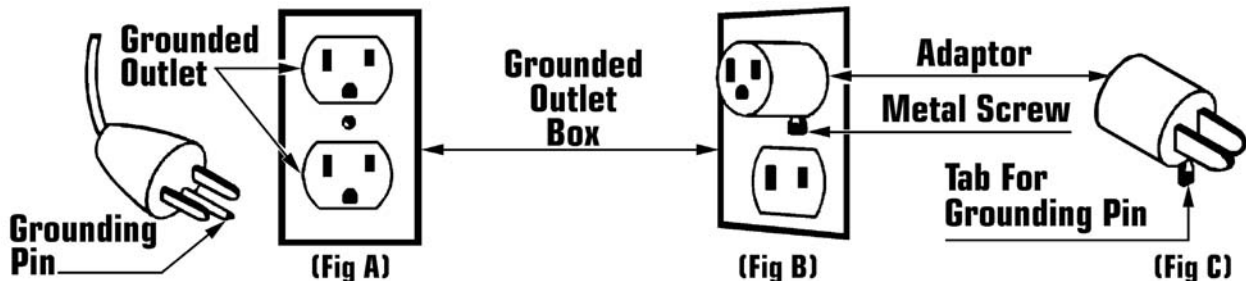

## **DANGER:**

DO NOT leave a plugged-in machine unattended.

# Attachments Installation & Changing



## **WARNING:**

When installing or changing the accessories, turn OFF the machine and disconnect the power cord from the electrical outlet.

### Before Installation Or Changing Attachments:

- 1) Unplug the machine from the wall outlet.
- 2) Ensure that the handle is in the storage position (straight up) and locked in place with the quick release pin.
- 3) Tilt machine back by bracing it with your foot until the handle is laying on the floor and the heads are fully exposed.
- 3) Push attachments on by hand and if necessary, carefully tap it into place with a rubber mallet.
- 4) Repeat steps 1 thru 4 with the remaining attachment.
- 5) Carefully raise the handle, supporting the axle with your foot to control the head of the machine as it is placed on the floor.

Note: It is recommended that a towel or pad is placed under the machine to protect both the floor and the machine.

### Installation and Changing of Attachments

- 1) Using both hands, reach beneath the bottom side of the first attachment and pull up towards yourself to free it from the machine.
- 2) Select the attachment required for the job, and line up the holes on the attachment with the four metal pins protruding from each of the heads.
- 5) Since the attachments are different heights, you may need to adjust the dust skirt to make sure it is level with the attachments. This will ensure clean and virtually dust-free operation.
- 6) To adjust skirt, align the skirt with the center of the machine and wrap it around.
- 7) Move the handle back to the operating position and lock in place with the quick release pin.
- 8) Move the handle back to the operating position and lock in place with the quick release pin.

Note: When installing or removing attachments, always wear protective gloves.

# Operating Instructions



## **Caution:**

DO NOT attempt to operate this unit if the machine is not fully assembled.

Prior to operating the machine, tilt machine back on transport wheels, **FULLY REMOVING THE TOOLS YOU HAVE ATTACHED OFF THE FLOOR**, turn ON the machine and carefully lower the machine onto the working surface.

When servicing or replacing accessories, first turn OFF the machine and disconnect from the power source.

- 1) Clear the floor of any materials or objects.
- 2) Select and install the accessory set required for the job. (See above for installation instructions.)
- 3) Move handle from the upright "storage" position to the angled "operating" position and lock in place with the quick release pin.
- 4) Place your hands on the handle grips tilt sander back on the transport wheels.
- 5) Engage the safety trigger and trigger lock beneath the right handle grip.
- 6) When the machine is running, carefully lower it onto the working surface and release the trigger lock.
- 7) To stop the machine release the safety trigger and it will automatically turn OFF.
- 8) Maintain a steady, consistent pace with the machine.
- 9) When not in use, a set of attachments **MUST** be left on the sander to protect the heads.

Note: If the machine unexpectedly shuts down due to a circuit overload, wait 30 seconds before restarting, then press the reset button .



## Vacuum Operating Instructions

### **WARNING:**

If this machine is used for sanding, **DO NOT** leave sawdust in the filter bag when the machine is not in use. This is a fire hazard.

This machine can be used with a variety of vacuums to pick up concrete dust.

Separate dedicated power sources for this machine and for the vacuum are recommended.

The vacuum hoses must be attached to the hose barbs on the back of the housing of the machine.

During operation, periodically check the vacuum. When the cloth or paper filter bag is 3/4 full or dust is forming around the bottom of the machine, it **MUST** be emptied.

Operation of the vacuum cleaner must be in accordance with specific manufacturer's safety and operation instructions.

## Belt Changing Instructions

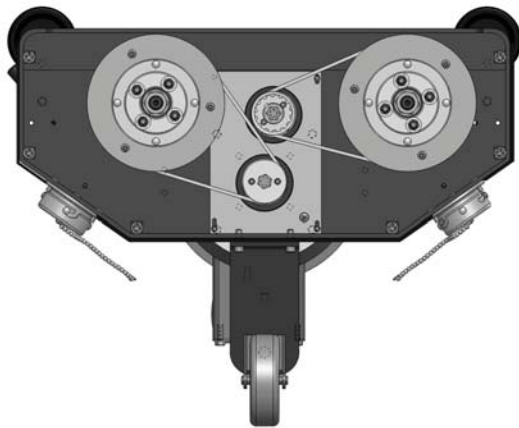

- 1) Unplug the motor power cord from the handle.
- 2) Pull the speed pin from the handle and remove the handle. Carefully set handle aside.
- 3) Turn the machine chassis upside down on a table resting on the motor cover.
- 4) Remove pads/attachments. (See Page 4)
- 5) Remove the six screws and lock washers from cover plate.
- 6) Remove the cover plate from housing.
- 7) Vacuum up the dust and debris from the housing cavity.
- 8) Remove old belt(s) by pulling upwards and rolling off using a screwdriver while turning the pulley.
- 9) Roll new belt(s) back on the pulley.
- 10) Reassemble the machine reversing the above steps.

## General Safety Precautions



### **DANGER:**

This machine is designed for surfacing concrete; all operators and maintenance personnel should read and understand the safety procedures with this floor machine.

- 1) All personnel in the immediate work area must wear safety glasses with side shields whenever the machine is in operation. Protective clothing is also recommended. Long sleeve shirts and safety shoes should be worn. Avoid wearing loose clothing.
- 2) **DO NOT** attempt to service or replace attachments while the machine is running or connected to a power source.
- 3) **DO NOT** operate this floor machine in the rain or in areas where liquids could enter the electrical components of the machine.
- 4) Keep the power cord away from the revolving heads to avoid damage.
- 5) Check main power supply to assure that you are connecting the equipment to a proper dedicated service.

# Gearbox Maintenance Instructions

## **WARNING:**

When checking or changing the grease in the gearbox of this machine, turn OFF the machine and disconnect the power cord from the electrical outlet.

- 1) Unplug the motor power cord from the handle.
- 2) Pull the speed pin from the handle and remove the handle. Carefully set handle aside.
- 3) Ensure grease gun fits over grease fitting on top of the housing.
- 4) Remove the plug on the user side of the motor.
- 5) Pump new grease into the gearbox cavity until grease is visible coming out of the unplugged hole.
- 6) Re-plug the hole.
- 7) Stow grease gun and re-attach handle.

## CASTER ADJUSTMENTS

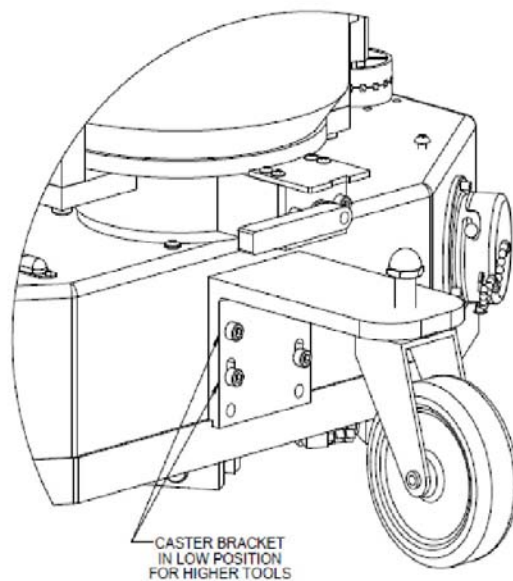
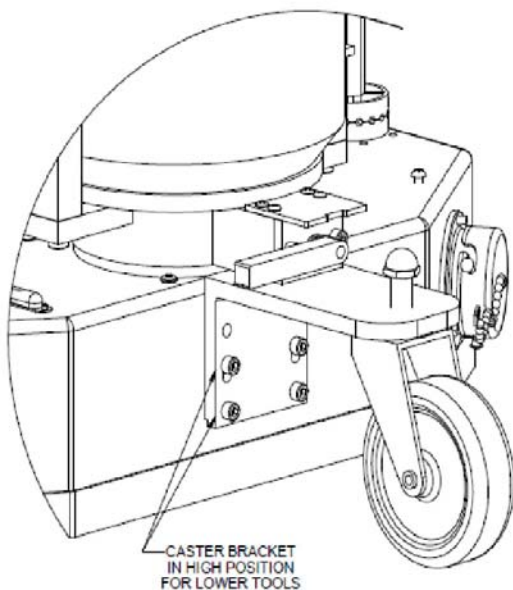

# About the Edge MP

The Mastercraft® Edger eliminates operator fatigue, reduces exposure to concrete dust and debris, and allows the operator to maintain a grind rate of 10 linear feet per minute.

## **Voltage**

The Edger is available in 460 volt three phase as well as 220 and 115 volt single phase.

## **Grinding Heads**

The Edger has 2 counter rotating grinding heads that provide a free floating feel during operation. No special tooling is required. The Edger was designed using standard Mastercraft® components so it interfaces with all Mastercraft® standard tooling.

## **Multiple Position Versatility**

The Edger incorporates an all new swivel base that allows the operator to position the base in a variety of positions with respect to the handle. This feature allows the unit to be adjusted for left or right handed operation and anything in between.

## **Wall Stand-offs**

The adjustable stand offs allow the grinding heads to be positioned flush against the wall or maintain up to 1 inch of clearance. This allows the operator to maneuver the unit effectively around common edge obstacles while maintaining a consistent grinding appearance.

## **Low Profile Design**

The all new low profile construction allows the unit to extend a full 2.5 inches under cabinets or shelving that is 3.5 inches high.

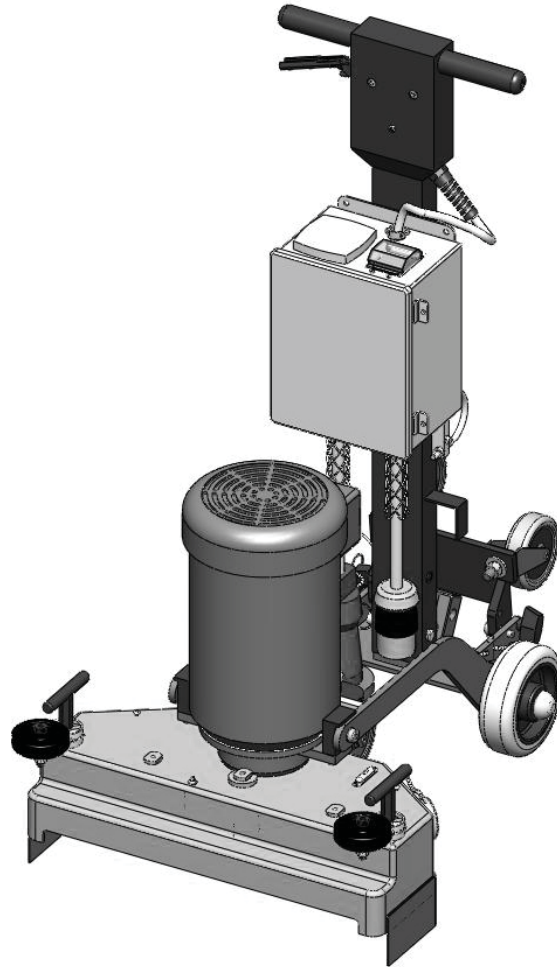

# Machine Maintenance



## **Warning:**

Always disconnect power cable from electrical outlet when working on the machine.

- 1) After each use, wipe off machine with a clean cloth.
- 2) Empty the vacuum you are using in accordance with specific manufacturer's safety and operation instructions.
- 3) Check for loose parts and fasteners
- 4) Check the power cord for any breaks in the wire. Breaks will most likely occur near the plug or switch. Repair or replace any breaks immediately.

# Machine Assembly Drawing & Parts List

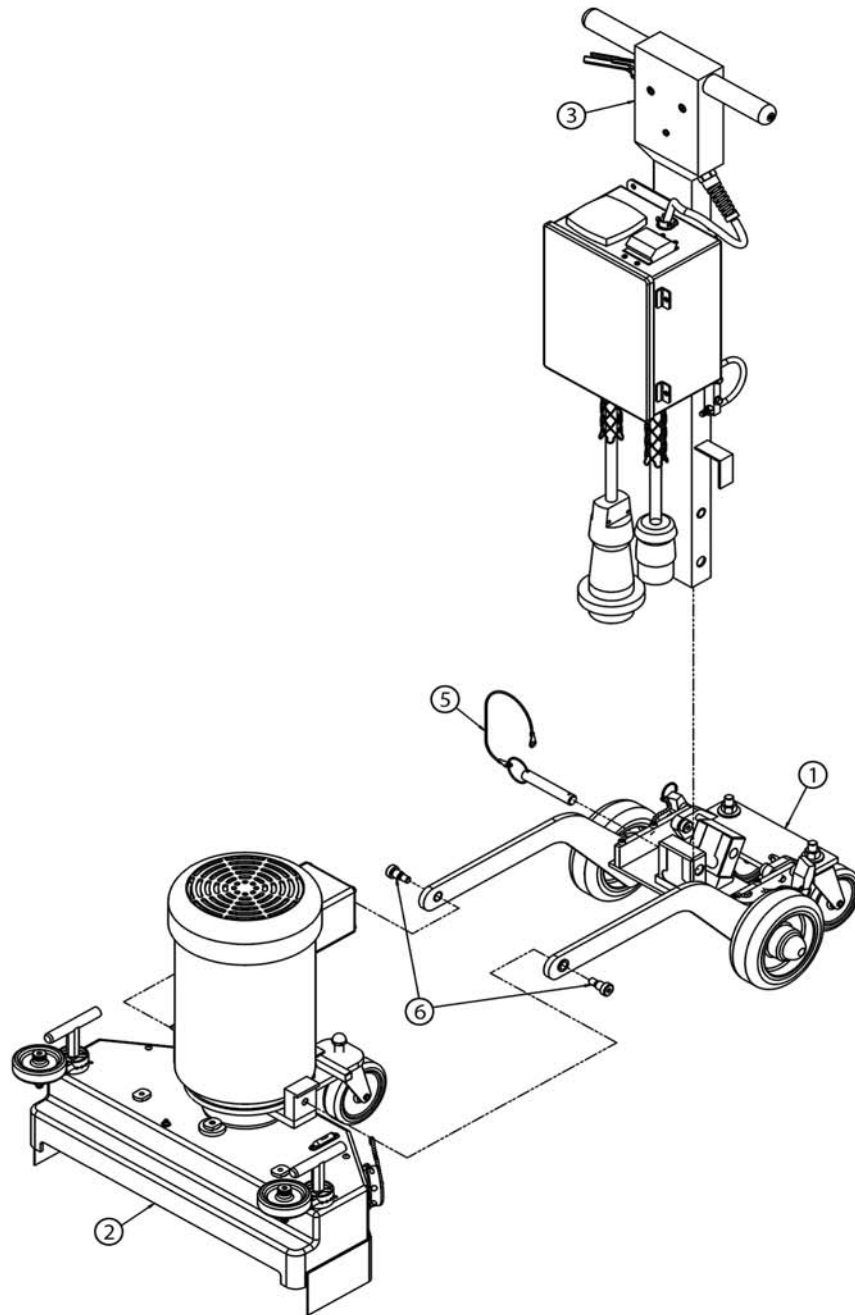

ITEM NO.	PART NUMBER	DESCRIPTION	QTY.
1	244236	FRAME ASSY, LONG & ADDITIONAL WHEEL	1
2	244333	HOUSING, MOTOR, PULLEYS	1
3	247642	HANDLE, CORD ASSY, 460V	1
5	456896	SPEED PIN ASSY .625 DIA X 3.00"	1
6	491063	SCREW, SHOULDER, .37-16 x .50" ALH BLAK OXIDE.	2



# Caster Assembly Drawing & Parts List

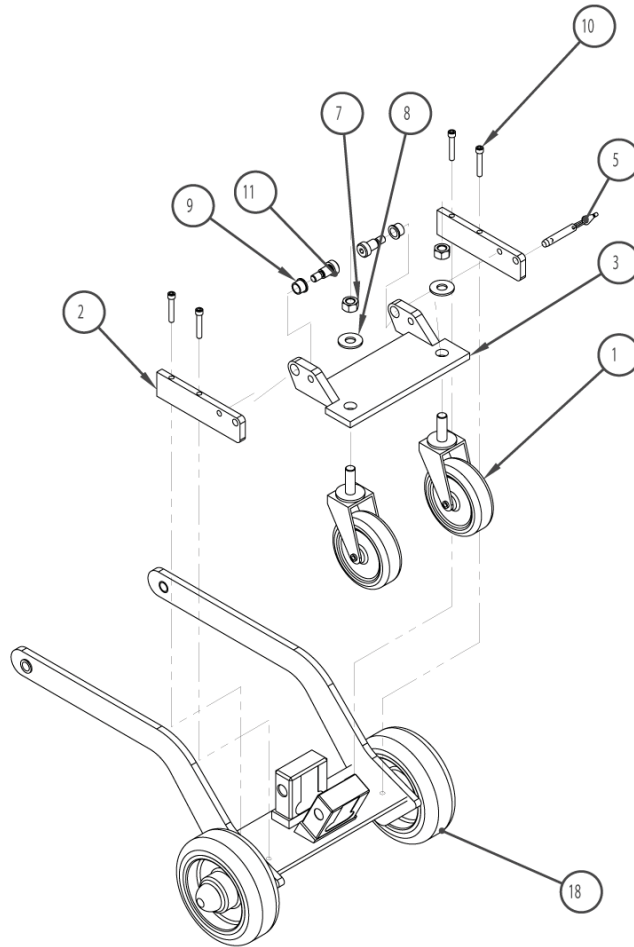

ITEM NO.	PART NUMBER	DESCRIPTION	QTY.
1	232440	CASTER,4.00",SWIVEL,ORAN,1.25"POLYURETHANE	2
2	244767	BRACKET,CASTER, FRAME	2
3	244856	BRACKET,CASTER FRAME	1
5	218170	SPEED PIN ASSY .375"DIA X 10.0 "	1
7	215228	NUT,NYLOK,0.50-13,STL^139	2
8	215201	WASHER,FLAT,0.50"ID,SAE,STL^139 >SWOOP	2
9	491055	BUSHING,BRONZE,.75OD X.50ID	2
10	245879	.250-20X1.5 CAP HEAD SCREW	4
11	232416	BOLT,SHOULDER,.50"SHOULDER DIAM X .625"L,	2
18	493716	FRAME, ASSY, RED, W/WHEELS 6"	1

# Handle and Cord Assembly Drawing & Parts List

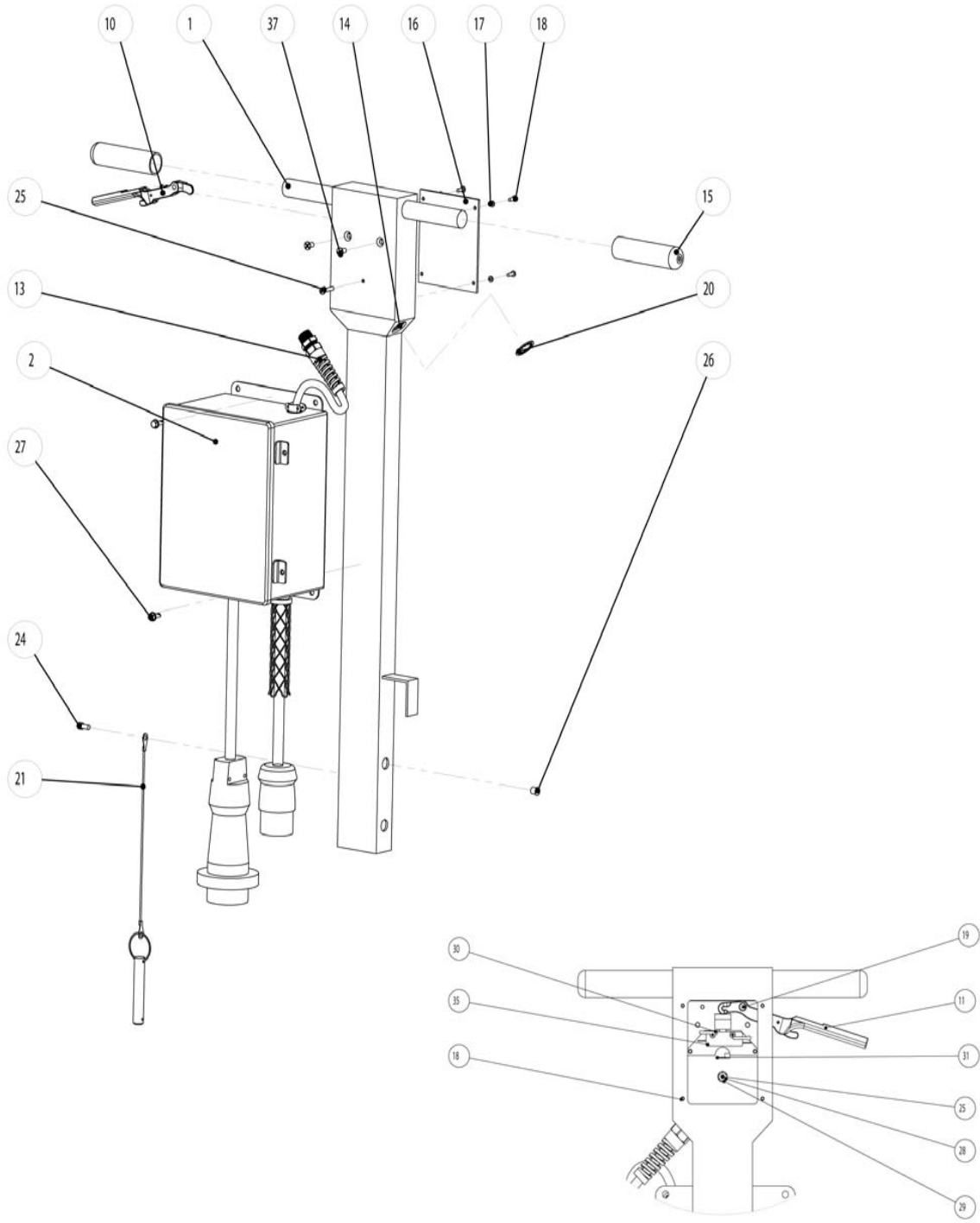

DETAIL A

ITEM NO.	PART NO.	DESCRIPTION	QTY	ITEM NO.	PART NO.	DESCRIPTION	QTY
1	495840	HANDLE ASSY,115V,BHMK	1	21	456896	SPEED PIN ASSY .625 DIA X 3.00"	1
2	257176	CONTROL BOX,ENCLOSURE 480v ASSEMBLY	1	479152	WIRE,RET,STL,PLASCOAT,10.00", W/2-.25" RING TERMS	1	
	462748	ELECTR BOX,JIC,GREY,	1	479128	WIRE,RET,STL,PLASCOAT,10.00", STRIP ENDS .50"	1	
	463256	STRAIN RELIEF, FLEXIBLE MESH, .54-.73 DIA	1	456861	TERMINAL,RING #.25",UNINSUL,>EZV SANDER	2	
	497657	0.50DIA. ROMEX CONNECTOR	1	490288	SPEED PIN ASSY, .65 X 3.00	1	
	233560	CORD,HNDL,14/4,STOW .46.00",W/480V-30A FEMALE TWST LOK	1	24	413291	SCREW, 1/4-20 X.50, ALLEN HEAD, STEEL	1
	464376	CORD,LINE,14/4,STOW,30",GREY,DE JACK 6.0" & 1.5",>OF54 BOX TO MTR	1	25	335169	#10-24x1.00 PAN HEAD, PHILLIP SCREW	1
	223050	PLUG,ELECTRICAL,480V,30A,4CON D,MALE,PIN & SLEEVE	1	26	234990	PLUG,PUSH- IN,PLAS,BLAK,>.375"DIA HL	1
	462837	480V, 30A, 3PH, FEMALE PLUG	1	27	237760	SCREW,.25-14 X .75 SELF TAPPING	2
	494119	CORD,BULK,BLAK,12/3,SJTOW,.43	1	28	331201	NUT,#10-24,HEX,W/EXT LCKWSH,ZINC^206	2
10	386839	KIT,TRIGGER,W/SPIROL ROLL PIN & SPR	1	29	342858	LOCKWASHER,.25",SPLIT,STL ^139	1
	383159	SPIROL ROLL PIN 1/8" X 9/16" LG	2	30	367168	TERMINAL,FLAG,INSUL,12 GA	2
	385654	TRIGGER,PLAS, > FM SW-BX	1	31	429015	TERMINAL,RING, INSUL,#10	1
	390119	TRIGGER LOCK,2.31 O.A.,RED VINYL DIP ON END	1	35	495867	SWITCH ASSY, W/BRACKET, >TRIGGER LOCK	1
13	434299	STRAIN RELIEF, FLEX.BLAK, .27"- .47"	1	335576	SCREW,#6- 32X1.00,PAN,PHLP,TYPE F,STL	2	
14	479160	STRAIN RELIEF,>15-24"FM	1	355224	LOCKWASHER,# 6,INT TOOTH	2	
15	490180	GRIP,HANDLE,BLAK	2	469637	SWITCH, MICRO,SPST,25 AMP,1.50HP,W/SPRING	1	
16	493481	PLATE, BACK, BHMK, W/HLS	1	335584	MICRO SWITCH SPRING	1	
	490091	PLATE, BACK, STL, RAW	1	469629	SWITCH,MICRO,SPST,25 AMP,1.50HP,W/2 HEX NUT	1	
17	380709	LOCKWASHER,# 8,INT TOOTH,STL ^139 >WAV	4	495824	TRIGGER SWITCH MOUNTING BLOCK	1	
18	385387	#8-32x0.25 PAN HEAD, PHILLIP SCREW	4	37	331740	SCREW,0.25-20 X 0.50,FLT,PHLP,STL^139	2
19	495875	#10-24x0.625 ALLEN HEAD, SHOULDER SCREW	1				
20	479179	LOCKWASHER,.87, TOOTHED	1				

# 480 Volt Wiring Diagram

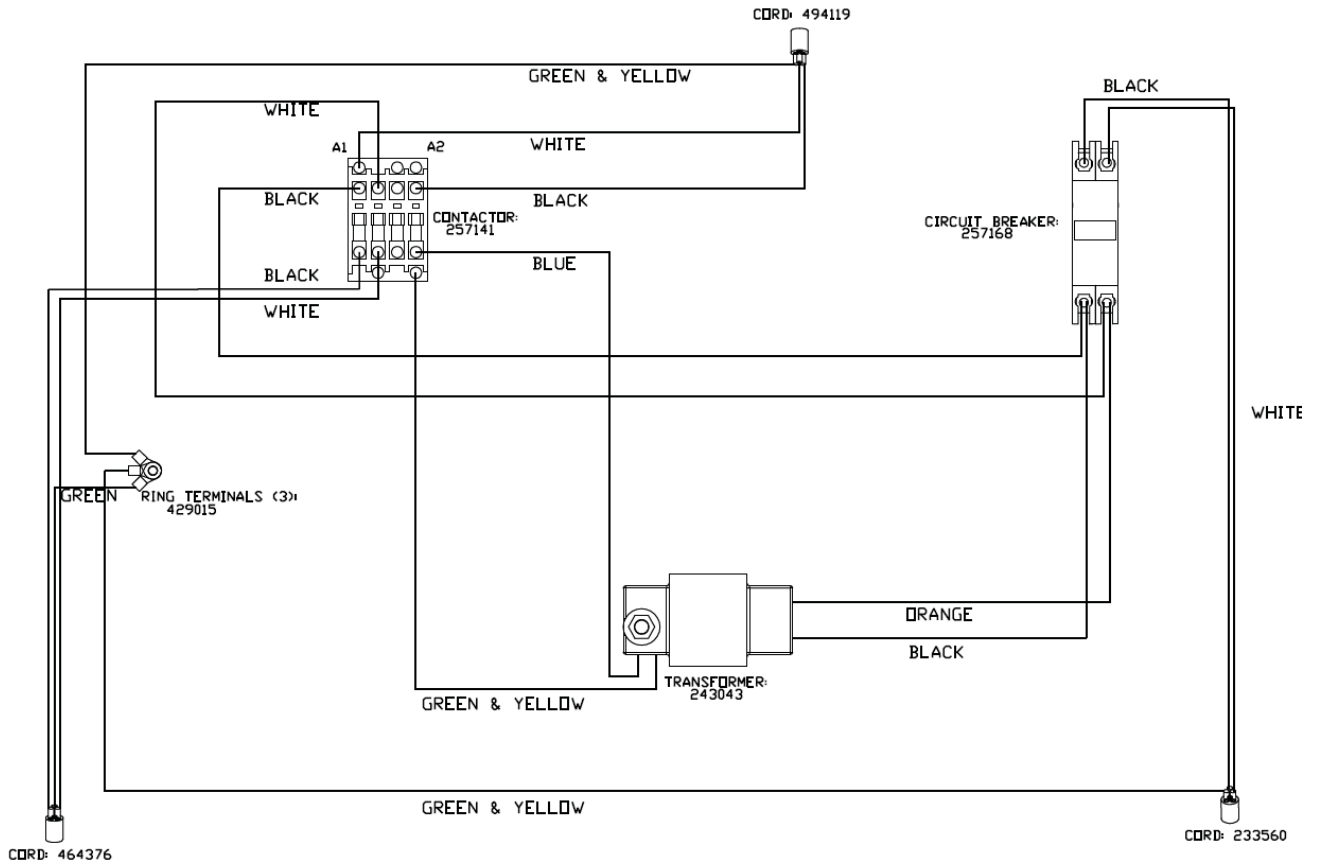

# Housing Assembly Drawings & Parts Lists

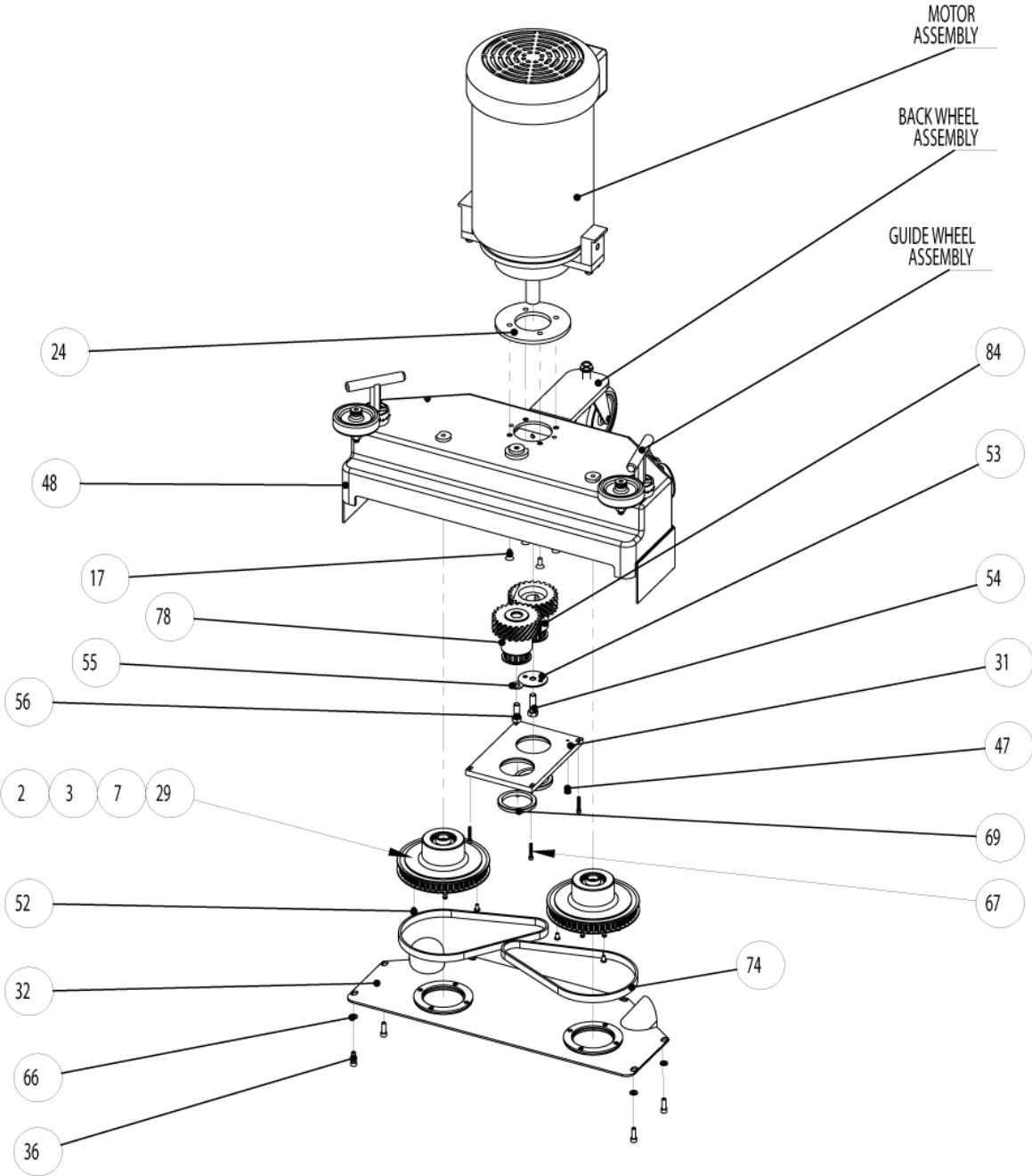

ITEM NO.	PART NUMBER	DESCRIPTION	QTY.
1	490555	SPACER, STL, 1.00"OD,.675"ID,.375"THK	
2	490628	NUT,NYLOK,.62-11,STL^139	2
3	490636	WASHER,STL,16MM ID,	2
4	222828	RING,2.76"IDX6.00"ODX0.08"THK,ALUM,W/3 COUNTRSNK HLS	
7	464910	BEARING, BALL, 1.57"ODX.67"IDX.47"W,W/ DOUBLE LIP	2
17	498882	SCREW, 0.25-20 X 1.00, FLT HD, SKT CAP, BLAK OXIDE	4
24	262188	SPACER, MOTOR MOUNT, BHMK	1
29	490512	PULLEY, HI, 5.5", W/ RING	2
31	244376	COVER,GEAR BOX	1
32	244457	COVERPLATE,GASKET ASSY	1
36	354775	SCREW, 0.25-20 X 1.00",ALH,STL,BLAK OXIDE^529	6
47	247936	SCREW, 10-32, PHIL, SEALING O-RING	1
48	244341	HOUSING ASSY,W/SHAFTS,BHMK	1
52	252743	SCREW,SOCKET/BUTTON,10-32 X .375	6
53	242357	WASHER, FLANGE, CRS, 1.90"OD, 0.40"ID, .08THK MACHINED	1
54	422940	BOLT,HEX,.37-16 x 1.25 ,ZN^206	1
55	232203	WASHER, FLAT, STEEL 3/8 SCREW SIZE .82 OD	1
56	368830	BOLT,HEX,.37-16 x 1.00",STL^139,UNSLTD,HEX HD	1
66	342858	LOCKWASHER,.25",SPLIT,STL ^139	6
67	263621	SCREW, 8-32 X 1", SOCKET CAP, BLAK OXIDE	4
69	263389	SEAL, "A" STYLE OIL SEAL, 2" X 2-1/2" X 1/4"	2
74	491918	BELT,TIMING,240L X .50",KEVLAR,>20" FM	2
78	263591	KIT, DRIVEN GEAR KIT >EDGER	1
84	263613	KIT, DRIVING GEAR KIT >EDGER	1

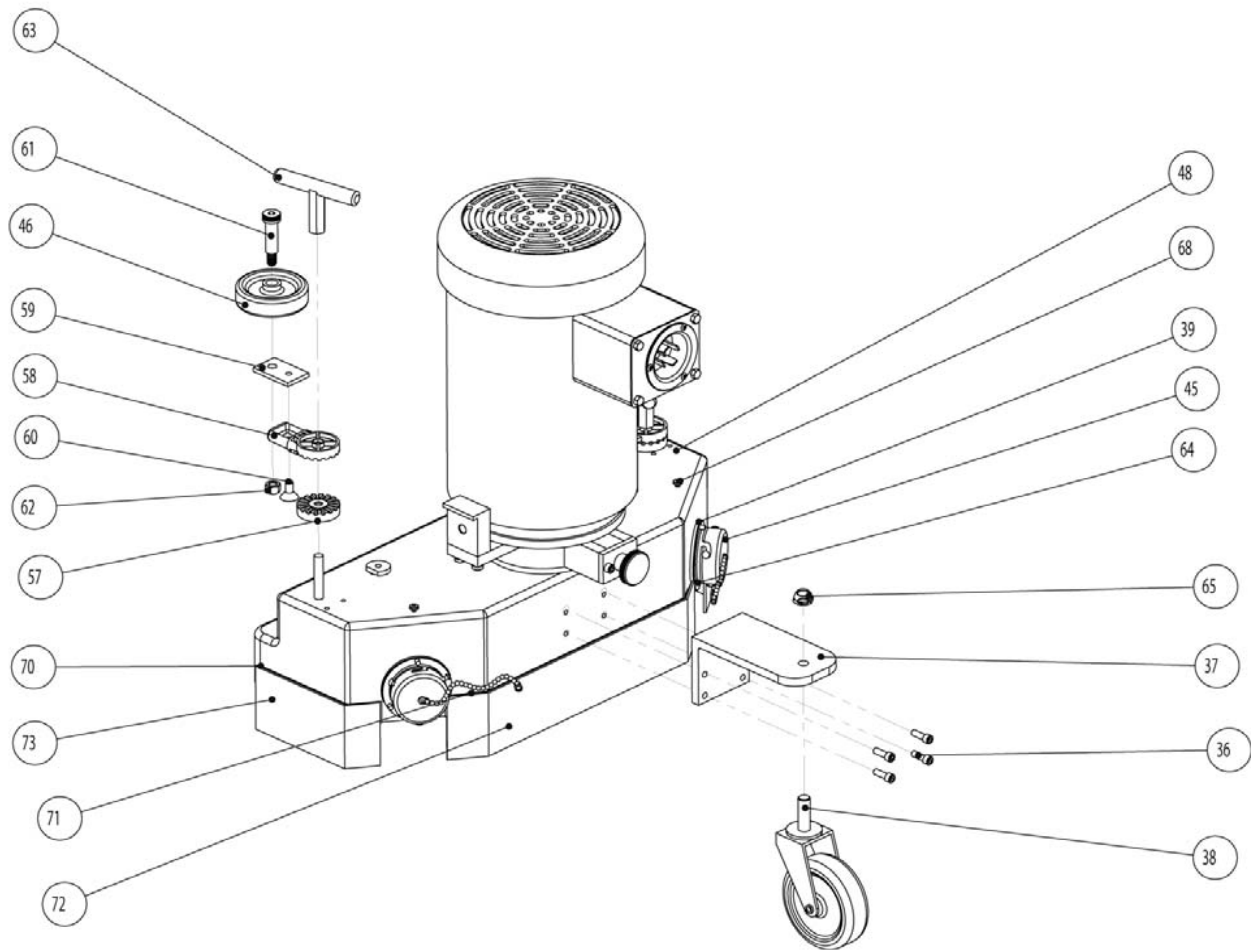

ITEM NO.	PART NUMBER	DESCRIPTION	QTY.
36	413291	SCREW, 0.25-20 X .50, ALH	4
37	244783	BRACKET,"L"	1
38	232440	CASTER,4.00",SWIVEL,ORAN,.1.25" POLYURETHANE	1
39	310999	CONN,EXH ,ZINC^108 W/SHOULDER RIVET,BB	2
45	349259	CAP,DR,SLTD,CRS,18 GA,ZN PLTD,W/CHAIN-6"	2
46	225150	WHEEL,SQUEEGE,STRIKER	2
48	244341	HOUSING ASSY,W/SHAFTS,BHMK	1
57	247456	BRACKET, UPPER JOINT, MACH	2
58	249270	BRACKET, LOWER JOINT, MACH	2
59	236470	PLATE, GUIDE WHEEL, EDGER HOUSING	2
60	256943	BOLT, FLAT HEAD, HEX 5/16X18 3/4 IN. LENGTH <EDGER	2
61	264008	BOLT, SHOULDER BOLT, 12" X 1-1/2, 3/8 UNC <EDGER	2
62	222895	NUT,NYLOK,.375-16,STL^139 >OF54-R1	2
63	262633	HANDLE,"T" BLAK,WHEEL BKT, HOUSING, <EDGER	2
64	318906	RIVET,POP,.18" X.62",AL & STL	6
65	263214	NUT, ACORN, 1/2-13, NICKEL-PLATED STEEL	1
68	385379	SCREW, #10-24 X 0.50, RND, PHLP, "F",THRD CUTTING,STL^13	2
70	263559	STRIP,VELCRO,1.00"x7-1/4, BLAK,HOOK ONLY,ADH BK,SIDE OF EDGER	2
71	263567	STRIP,VELCRO,1.00"x13-3/4,BLAK,HOOK ONLY,ADH BK, BACK OF EDGER	1
72	263583	SKIRT,RBR,BLAK,W/VELCRO LOOP,3.00"x13-3/4", BACK OF EDGER	1
73	263575	SKIRT,RBR,BLAK,W/VELCRO LOOP,3.00"x7-1/4", SIDE OF EDGER	2



# Motor Assembly Drawing & Parts List

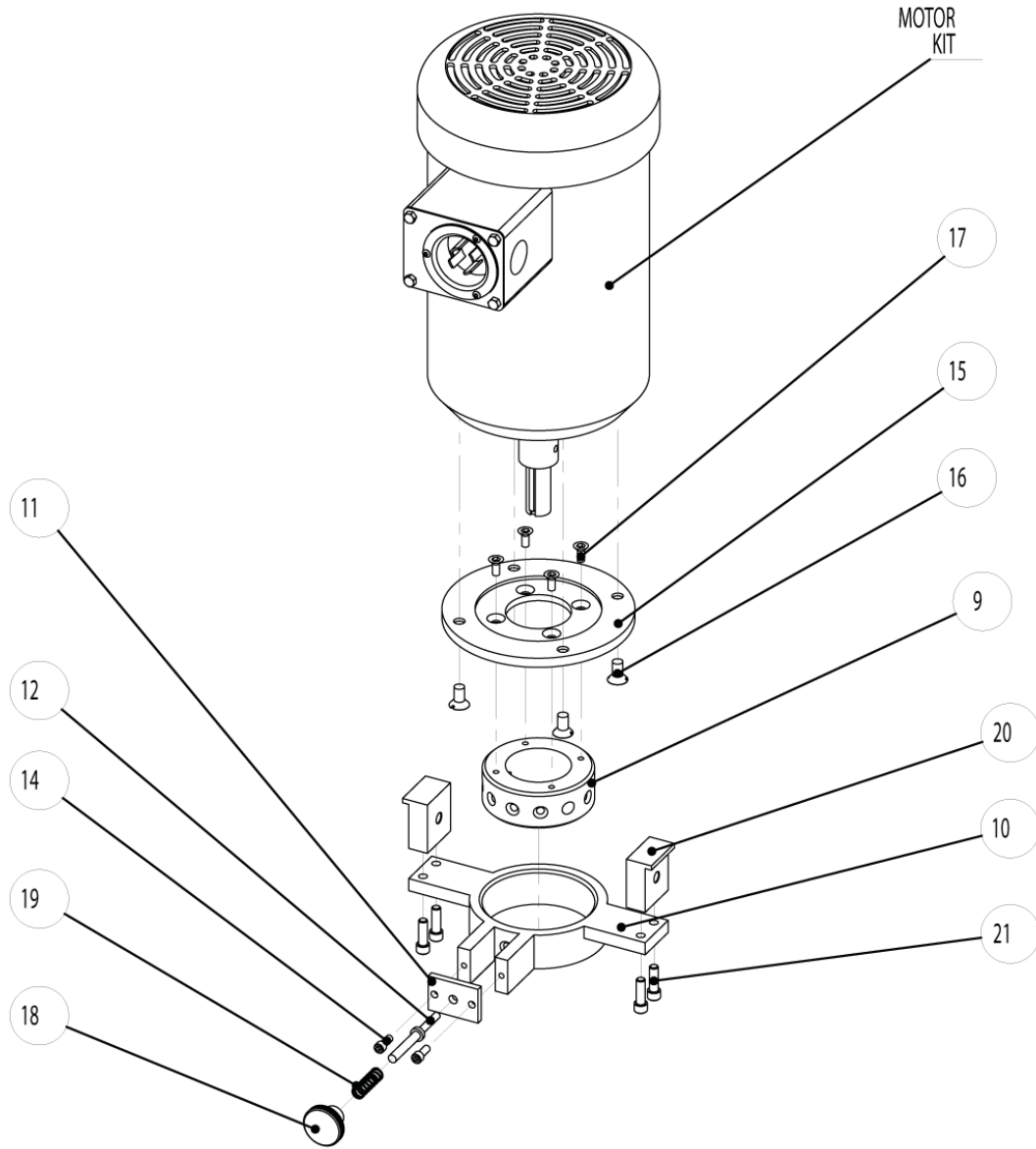

ITEM NO.	PART NUMBER	DESCRIPTION	QTY.
9	244244	MOUNT,POSITIONING ARM	1
10	244791	BRACKET,W/POSITIONING & ARM	1
11	244805	PLATE,POSITIONING ARM	1
12	245143	PIN,POSITIONING ARM,CRS	1
14	457310	SCREW, 0.25-20 X.62,ALH,BLAK OXIDE,STL^139	2
15	245135	MOUNT,ROTATING MOTOR PLATE	1
16	245178	BOLT,CS,SLOT,.375-16 X .75"	4
17	498890	SCREW,.25-20 X .62, FLT HD	4
18	244821	KNOB,1.5 DIA, THRD,W/KNURL	1
19	263311	SPRING, COMPRESSION SPRING, 1.5", OD .48", WIRE SIZE .045", STEEL	1
20	263370	BRACKET, MOUNT,ARM,STL, BHMK, <EDGER	2
21	490350	5-16-18x1.00 ALLEN HEAD, CAP SCREW	4

# Troubleshooting Guide

<u>Problem</u>	<u>Possible Cause</u>	<u>Possible Solution</u>
<b>MOTOR WILL NOT RUN</b>	<ol style="list-style-type: none"> <li>1. Defective switch</li> <li>2. Defective power cord or wiring</li> <li>3. Defective motor</li>   <li>4. Blown fuse or tripped circuit breaker at wall panel</li>   <li>5. Power cord not plugged in properly or damaged</li> </ol>	<ol style="list-style-type: none"> <li>1. Check and replace if defective.</li> <li>2. Check and replace if defective.</li> <li>3. Have motor checked by an authorized service center.</li> <li>4. Replace fuse or reset circuit breaker. If this doesn't correct the problem, have the machine checked by an authorized service center.</li> <li>5. Plug in power cord properly or replace if damaged.</li> </ol>
<b>MACHINE BOGS DOWN AND RUNS SLOW</b>	<ol style="list-style-type: none"> <li>1. Defective capacitor or switch</li> <li>2. Circuit may be overloaded with more than one appliance</li>   <li>3. Low line voltage in building</li> </ol>	<ol style="list-style-type: none"> <li>1. Have machine checked by an authorized service center.</li> <li>2. Plug machine into a dedicated power outlet. Have the machine checked by an authorized service center.</li> <li>3. If wiring is old in building, have voltage checked by the power company.</li> </ol>
<b>NOISY MACHINE OR VIBRATION</b>	<ol style="list-style-type: none"> <li>1. Defective motor</li> <li>2. Attachment is not level or securely attached</li> </ol>	<ol style="list-style-type: none"> <li>1. Contact the manufacturer or an authorized service center.</li> <li>2. Level attachment and make sure all fasteners are secure.</li> </ol>
<b>MOTOR RUNS, BUT DRIVER WILL NOT ROTATE</b>	<ol style="list-style-type: none"> <li>1. Belt is broken</li> </ol>	<ol style="list-style-type: none"> <li>1. Replace belt.</li> </ol>

## Warranty Information

We guarantee, to the original purchaser of this floor machine, against defects in material and workmanship for a period of 1 year from the date of delivery. Please note the following conditions pertaining to this warranty.

- 1) This warranty does not apply to any repair arising by reason of misuse, neglect, or abuse, or to proprietary parts.
- 2) Applies only to the original owner and is not transferable.
- 3) Machine will not have been dismantled or tampered with in any way.

- 4) Covered components proven defective will be repaired or replaced at no charge. Covered components include motors, bearings, belts and switches.
- 5) This warranty is in lieu of and excludes every condition or warranty not herein expressly set out and all liability for any form of consequential loss or damage is hereby expressly excluded.
- 6) This warranty is limited to repair or replacement of covered components and reasonable labor expenses.

# Important Safety Instructions



## **WARNING:**

To reduce the risk of fire, electric shock, or injury; read all instructions before using this machine. When using this machine, basic precautions should always be followed, including the following:

- 1) DO NOT leave the floor machine plugged in when not in use. Unplug from the outlet when not in use and/or before servicing.
- 2) Electric shock could occur if exposed to rain. Store indoors.
- 3) This is NOT a toy. Close attention is necessary when used around or near children.
- 4) Use only as described in this manual. Use only manufacturer's recommended attachments.
- 5) DO NOT use with damaged cord plug.
- 6) If the floor machine is not working as it should because it has been dropped, damaged, left outdoors, or dropped into water, contact the manufacturer or authorized service center.
- 7) DO NOT handle the plug or operate with wet hands.
- 8) DO NOT pull or carry by cord, use power cord as a handle, close a door on cord, or pull cord around sharp edges or corners. DO NOT run floor machine over the cord. Keep cord away from heated surfaces.
- 9) DO NOT unplug by pulling on cord. To unplug, grasp plug, not the power cord.
- 10) DO NOT put any object into motor openings.
- 11) Keep hair, loose clothing, fingers and all parts of body away from moving parts.
- 12) DO NOT use an optional vacuum without the manufacturer's filters in place.
- 13) DO NOT operate where anesthetics and oxygen are used.
- 14) DO NOT use an extension cord.
- 15) DO NOT use around flammable or combustible liquids such as gasoline or use in areas where they may be present.
- 16) Replace damaged or worn parts immediately with genuine Grind 'N Go equipment parts to maintain safety and protect your limited warranty.
- 17) Floor sanding can result in an explosive mixture of fine dust and air. Use a floor sanding machine only in a well ventilated area.
- 18) This floor machine must be connected to a properly grounded outlet only. (See Grounding Method, Page 3.)

# Grounding Safety Instructions



## **DANGER:**

Improper use of the grounding plug can result in a risk of electrical shock.

This floor machine must be grounded. If it should malfunction or breakdown, grounding provides a path of least resistance for electrical current thus, reducing the risk of electric shock. This machine is equipped with an equipment-grounded plug. The plug must be inserted into an appropriate outlet that is properly installed and grounded in accordance with all local codes and ordinances

If repair or replacement of the cord or plug is necessary, DO NOT connect the grounding wire to either flat blade terminal. The insulated wire with an outer surface that is green with or without yellow stripes is the grounding wire.