

SAFETY, OPERATION, & MAINTENANCE MANUAL w/PARTS LIST WIDE AREA VACUUMS

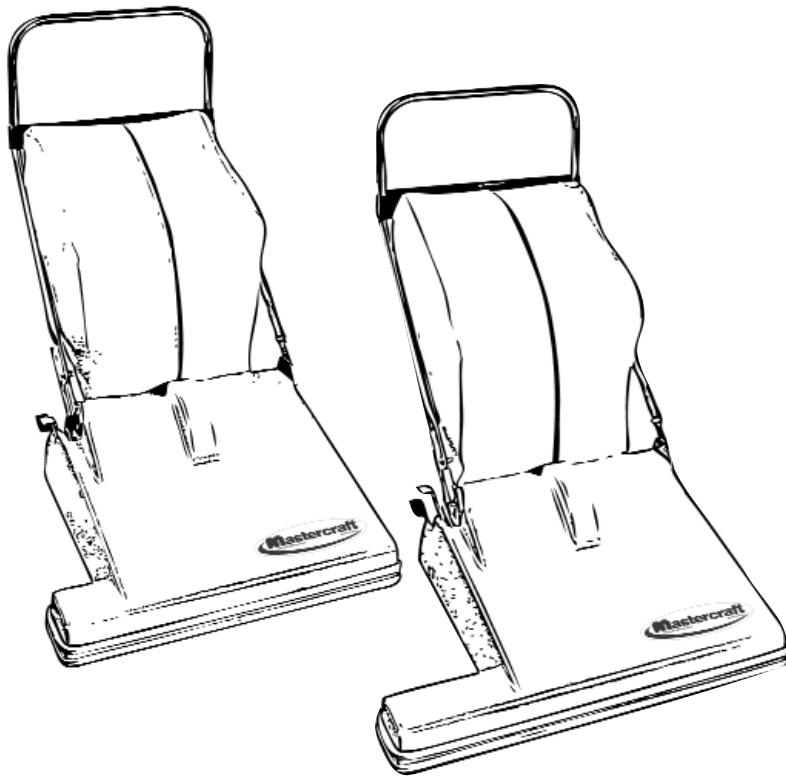

This unit is intended for commercial use.

Mastercraft

READ & FOLLOW ALL INSTRUCTIONS, WARNINGS & CAUTIONS BEFORE USING THIS VACUUM

This vacuum cleaner will afford you many years of trouble-free operating satisfaction, provided it is given proper care. All parts have passed rigid quality control standards prior to being assembled to produce the finished product. Prior to packaging, this vacuum was again inspected for assurance of flawless assembly.

Your vacuum is protectively packed to prevent damage in shipment. We recommend that upon delivery, unpack the vacuum and inspect it for any possible damage. Only a visual examination will reveal damage that may have occurred.

If damage is discovered, immediately notify the transportation company that delivered your vacuum. As a shipper, we are unable to report claims for concealed damage. You must originate any claims within 5 days.

This manual is for your protection and information. **PLEASE READ CAREFULLY** since failure to follow precautions could result in discomfort or injury.

**PLEASE READ
CAREFULLY
BEFORE
OPERATING**

SAVE THESE INSTRUCTIONS

IMPORTANT SAFETY INSTRUCTIONS



WARNING:

To avoid electric shock, **DO NOT** expose to rain.
Store Indoors
When using this electric vacuum, basic precautions should always be followed, including the following:

- 1} **DO NOT** leave the vacuum when plugged in. Unplug it from the outlet when not in use and before servicing.
- 2} This is **NOT** a toy. Close attention is necessary when used around or near children.
- 3} To avoid electric shock, **DO NOT** use outdoors or on wet surfaces.
- 4} Use this vacuum only as described in this safety manual. Use only manufacturer's recommended attachments and accessories.
- 5} **DO NOT** use this vacuum with a damaged cord or plug. If the vacuum is not working as it should, because it has been dropped, damaged, left outdoors or dropped into water, contact an authorized service center or factory.
- 6} **DO NOT** pull the vacuum by the cord, use cord as a handle, close a door on the cord or pull cord around sharp edges and corners. **DO NOT** run vacuum over the cord. Keep cord away from heated surfaces.
- 7} **DO NOT** unplug the vacuum by pulling on the cord. To unplug, grasp the plug, not the cord.
- 8} Store vacuum indoors in a dry area.
- 9} **DO NOT** handle the vacuum plug or vacuum with wet hands.
- 10} **DO NOT** put any objects into the openings. **DO NOT** use with any openings blocked; keep free of dust, lint, hair, and anything that may reduce air flow.
- 11} Turn **OFF** all of the controls before unplugging.
- 12} Keep hair, loose clothing, fingers, and all parts of the body away from openings and moving parts.
- 13} **DO NOT** pick up anything that is smoking or burning such as cigarettes, matches, or hot ashes.
- 14} **NEVER** vacuum floors, carpets or rugs that are wet. **NEVER** vacuum up liquids with this vacuum.
- 15} **DO NOT** use without dust bag and/or filters in place.
- 16} **DO NOT** use this vacuum to pick up flammable or combustible liquids such as gasoline or use in areas where they may be present.
- 17} **DO NOT** use where oxygen or anesthetics are used.
- 18} Replace damaged or worn parts immediately with genuine original equipment parts to maintain safety and to protect your limited warranty.
- 19} **DO NOT** use this vacuum to pickup hard or sharp objects such a coins, pins, nails etc., as they will damage the vacuum and filter bags.
- 20} **DO NOT** use an extension cord unless absolutely necessary. If an extension cord is used, then wire size must be #14 gauge or larger and should not exceed 50 feet in length. The extension cord must be three-wire type to insure **GROUNDING** protection.

This vacuum must be connected to a properly grounded outlet only. See grounding instructions (Page 3).

SAVE THESE INSTRUCTIONS



DANGER:

Improper use of the grounding plug can result in a risk of electric shock.

GROUNDING INSTRUCTIONS

Electrical equipment must be grounded. If it should malfunction or breakdown, grounding provides a path of least resistance for electrical current to reduce the risk of electric shock. This vacuum is equipped with a cord having an equipment-grounding conductor and grounding plug. The plug must be inserted into an appropriate outlet that is properly installed and grounded in accordance with all local codes and ordinances.

If repair or replacement of the cord or plug is necessary, **DO NOT** connect the grounded wire to either flat blade terminal. The wire with insulation having an outer surface that is green with or without yellow stripes is the grounding wire.

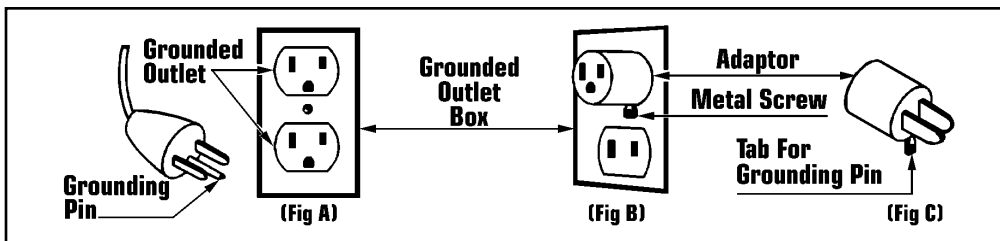

This electric equipment is for use on a nominal 120 volt circuit, and has a grounded plug that looks like the plug illustrated in (Fig A). A temporary adaptor that looks like the adaptor illustrated in (Fig B & C) may be used to connect this plug to a 2-pole receptacle as shown in (Fig B) if a properly grounded outlet is not available.

The temporary adaptor should be used only until a properly grounded outlet (Fig A) can be installed by a qualified electrician. The green color rigid ear, lug or the like extending from the adaptor must be connected to a permanent ground such as a properly grounded outlet box cover. Whenever the adaptor is used, it must be held in place by a metal screw. (See Fig B)

GROUNDING METHODS

WARNING:

Improper connection of the equipment-grounding conductor can result in a risk of electric shock. Check with a qualified electrician or service person if you are in doubt as to whether the outlet is properly grounded.

DO NOT modify the plug provided with the equipment. If it will not fit the outlet, have a proper outlet installed by a qualified electrician.

Note: In Canada, the use of a temporary adaptor is not permitted by the Canadian Electrical Code.

Treat this vacuum as you would any other high grade precision made product. Dropping, unreasonable bumping across thresholds and other misuses may result in a damaged unit which will not be covered by warranty.

Read this manual completely before operating the vacuum. It is important to follow instructions in this manual to prevent the possibility of injury or damage to the user and/or vacuum.

CARE OF THIS VACUUM

LIRE TOULES LES INSTRUCTIONS AVANT DE FAIRE FONCTIONNER



AVERTISSEMENT:

Pour réduire les risques d'incendie, de choc électrique ou de blessure:
POUR APPAREIL SEC
Pour réduire les risques de choc électrique, ne pas aspirer de matières humides, ne pas exposer à la pluie et garder l'aspirateur à l'intérieur.

L'utilisation d'un appareil électrique demande certaines précautions:

1} Ne pas laisser l'appareil sans surveillance lorsqu'il est branché. Débrancher lorsque l'appareil n'est pas utilisé et avant l'entretien.

2} Ne pas permettre aux enfants de jouer avec l'appareil. Une attention particulière est nécessaire lorsque l'appareil est utilisé par des enfants ou à proximité de ces derniers.

3} N'utiliser que conformément à cette notice avec les accessoires recommandés par le fabricant.

4} Ne pas utiliser si le cordon ou la fiche est endommagé. Retourner l'appareil à un atelier de réparation s'il ne fonctionne pas bien, s'il est tombé ou s'il a été endommagé, oublié à l'extérieur ou immergé.

5} Ne pas aspirer de matières en combustion ou qui dégagent de la fumée, comme des cigarettes, des allumettes ou des cendres chaudes.

6} Ne pas tirer, soulever ou traîner l'appareil par le cordon. Ne pas utiliser le cordon comme une poignée, le coincer dans l'embrasure d'une porte ou l'appuyer contre des arêtes vives ou des coins. Ne pas faire rouler l'appareil sur le cordon. Garder le cordon à l'écart des surfaces chaudes.

7} Ne pas débrancher en tirant sur le cordon. Tirer plutôt la fiche.

8} N'insérer aucun objet dans les ouvertures. Ne pas utiliser l'appareil lorsqu'une ouverture est bloquée. S'assurer que de la poussière, de la peluche, des cheveux ou d'autres matières ne réduisent pas le débit d'air.

9} Ne pas toucher la fiche ou l'appareil lorsque vos mains sont humides.

10} Maintenir les cheveux, les vêtements amples, les doigts et toutes les parties du corps à l'écart des ouvertures et des pièces mobiles.

11} Ne pas utiliser l'appareil si le sac à poussière ou le filtre n'est pas en place.

12} Mettre toutes les commandes à la position ARRET avant de débrancher l'appareil.

13} User de prudence lors du nettoyage des escaliers.

14} Ne pas aspirer des liquides inflammables ou combustibles, comme de l'essence, et ne pas faire fonctionner dans des endroits où peuvent se trouver de tels liquides.

15} Toujours mettre l'interrupteur de l'appareil à la position ARRET avant de brancher ou de débrancher la brosse à moteur.

16} Ne brancher qu'à une prise de courant avec mise à la terre. Voir les instructions visant la mise à la terre.

INSTRUCTIONS VISANT LA MISE A LA TERRE

Cet appareil doit être mis à la terre. En cas de défaillance ou de panne éventuelles, la mise à la terre fournit au courant un chemin de moindre résistance qui réduit le risque de choc électrique. Cet appareil est pourvu d'un cor-

don muni d'un conducteur de terre et d'une fiche avec broche de terre. La fiche doit être branchée dans une prise appropriée correctement installée et mise à la terre conformément aux règlements et ordonnances municipaux.

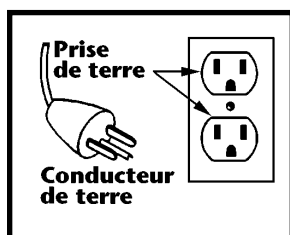

Cet appareil est destiné à un circuit de 120V et est muni d'une fiche de mise à la terre semblable à celle illustrée par le croquis A de la figure "A". S'assurer que l'appareil est branché à une prise de courant ayant la même configuration que la fiche. Aucun adaptateur ne devrait être utilisé avec cet appareil.

AVERTISSEMENT:

Un conducteur de terre mal raccordé peut entraîner un risque de choc électrique. Consulter un électricien ou un technicien d'entretien qualifié si vous n'êtes pas certain que la prise soit cor-

rectement mise à la terre. Ne pas modifier la fiche fournie avec l'appareil si elle ne peut être insérée dans la prise, faire installer une prise adéquate par un électricien qualifié.

CONSERVER CES INSTRUCTIONS

This vacuum is designed to efficiently clean large areas of carpets. It also performs very well on hard surface floors. The heavy duty motor provides power for the brush and rotating fan. The large capacity filter bag, foot switch and foot pedal for nozzle height adjustment provide convenient operation.

The Chevron pattern brush pushes dirt toward center of the brush and vacuum inlet for pickup.

In areas where more than average dirt is present, it is recommended that a second pass be made over the surface.

Back up the vacuum to lift carpet nap, thus helping to remove the heavy, deep dirt or sand.

This vacuum must be connected to the correct power source to correspond to the data on the name plate.

ABOUT THE WIDE AREA VACUUM

1} Remove the wide area vacuum from the carton.

2} Flip the handle up into the upright position and secure in place with the speed pin attached to the handle bracket.

3} Remove cloth filter bag from the carton and attach it to vacuum with zipper, facing the front of the unit. Stretch mouth of the bag completely over discharge port on back of vacuum. See fig 2.

4} Assemble the hose and bag adaptor to the cast discharge deflector at rear of the vacuum, with bag adaptor facing front of unit. See fig 2.

5} Install a paper filter bag to the bag adaptor by grasping the bag's cardboard collar, pulling it forward on to the adaptor.

6} Zip up the filter bag and secure it to the handle with wrap-around velcro strap.

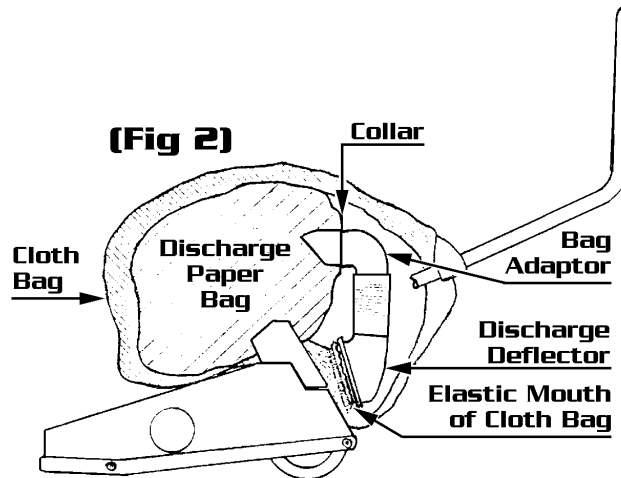

OPERATION INSTRUCTIONS

1} When removing the dust bag or inspecting the blower fan and brush, disconnect power cord plug from the wall outlet.

2} The brush belt guard and thread guard are designed to prevent threads and strings from binding the brush. Inspect the brush frequently for obstructions and removed them to prevent damage to bristles.

3} **DO NOT** pickup large metal slugs, metal shavings or similar debris. Also, care must be taken so as not to suck up loose carpet or other such bulky articles.

4} When the vacuum is not in use or in storage, to prevent damage, lift brush bristles off the floor.

5} Wrap the power cord around the handle when the vacuum is not in use.

6} The vacuum handle can be stored in the full vertical position or folded down flat in the vertical positioned for packing.

7} Periodically the motor should be cleaned out using compressed-air. Especially when used on new carpet or in a dusty area.

OPERATION AND CARE INFORMATION

BRUSH NOZZLE AND BELT ADJUSTMENT

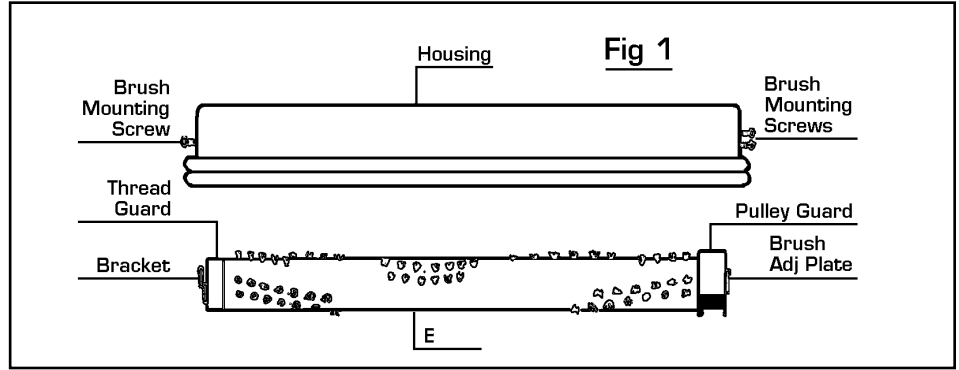

Brush Adjustment

The top pedal at the right rear is used to adjust the brush up from the carpet floor. There are five basic settings that can be changed by adjusting the front caster height. Adjust the caster so it provides level contact of the bristles to the carpet floor.

To lower the brush, depress the lower pedal at right rear of the vacuum, using slow positive pressure, release one notch of ratchet at a time.

Nozzle Adjustment

The nozzle should be set for various carpet nap heights. Carpets with low nap use the lower settings, high nap the higher settings. The highest settings consistent with good cleaning should be used for the type of carpet being cleaned.

Setting nozzle lower than necessary may not result in good cleaning performance. Excessive wear to the carpet and brush bristles occurs and the vacuum is difficult to push.

Belt Adjustment

Adjust the belts for wear by loosening the brush mounting screws. Pull the brush forward until the belt is taut, retighten the screws.

See brush assembly schematic, parts list and fig 1.

CARE AND MAINTENANCE

Cloth Filter Bag

The outside cloth filter bag should be kept clean for best cleaning results.

To Clean:

1} Release velcro bag strap, remove paper filter bag and cloth bag. Turn the cloth bag inside out through the zipper opening and shake out bag.

2} Replace the cleaned cloth filter bag and install a new paper filter bag.

Brush Assembly

When the brush assembly is worn it must be replaced.

To Replace:

1} Remove the belt cover, screws (2) at each end of the brush housing.

2} Remove the bracket, thread guard, install new brush and re-assemble.

3} Replace belt and adjust as instructed above

Power Cord

Check the power cord for worn spots, and breaks. Replace if defective for safety of the operator.

When the vacuum is not in use wrap the cord around the handle.

HELPFUL CLEANING TIPS

1} On heavily soiled carpet, push the vacuum back and forth. This lifts the carpet pile and helps remove dirt.

1} On hard floor surfaces use the lowest setting.

1} Airborne dust is kept to a minimum when the cloth filter bag and paper filter bag are kept clean.

HOUSING/BAG/HANDLE REPLACEMENT PARTS LIST

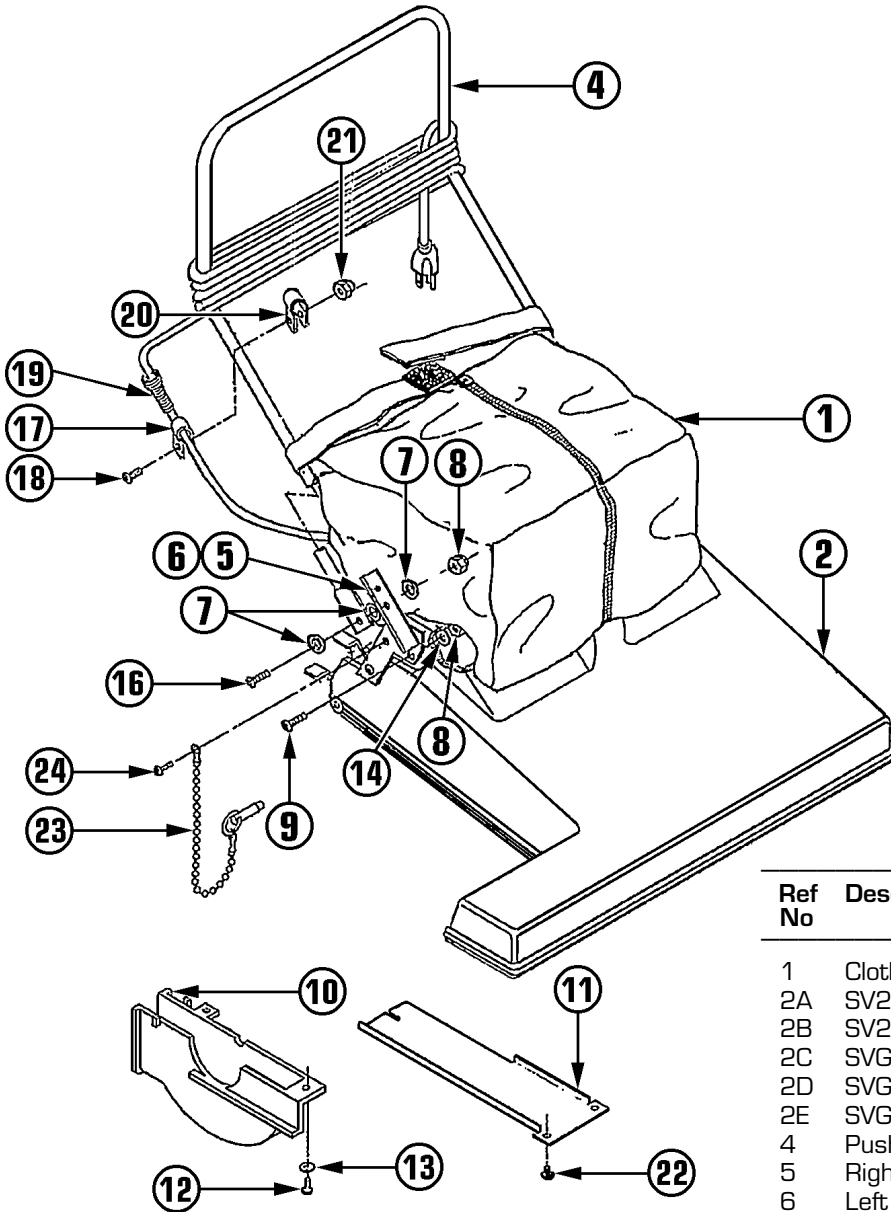

Ref No	Description	Qty	Part No
1	Cloth Filter Bag (Grey)	1	240125
2A	SV200 - 20" Housing (Blue)	1	381926A
2B	SV240 - 24" Housing (Blue)	1	396036A
2C	SVG201 - 20" Housing (Blue)	1	317667A
2D	SVG241 - 24" Housing (Blue)	1	314609A
2E	SVG281 - 28" Housing (Blue)	1	396044A
4	Push Handle	1	318523
5	Right Handle Bracket	1	315583
6	Left Handle Bracket	1	315591
7	Flat Brass Washer	6	380679
8	1/4- 20 Nylock Nut	6	380784
9	1/4- 20 X 7/8" Screw	4	318884
10	Fan Cover	1	381195
11	Intake Cover	1	381268
12	8 - 32 X 1/4" Screw	2	380598
13	#8 Int Tooth Lockwasher	2	380709
14	Flat Washer	4	380652
16	1/4- 20 X 3/4" Screw	2	342831
17	Clamp	1	381055
18	1/4- 20 X 5/8" Hex Bolt	1	360848
19	2 3/4 X 3/4" Spring	1	381160
20	7/8" Clip w/Vinyl	1	318922
21	1/4- 20 Acorn Nut	1	328146
22	8-32 X 3/8" Screw	3	367389
23	Speed Pin Assembly	1	321001
24	10 - 24 X 1/2" Self-Tap Screw	1	385379

MOTOR & BRUSH DRIVE

REPLACEMENT PARTS LIST

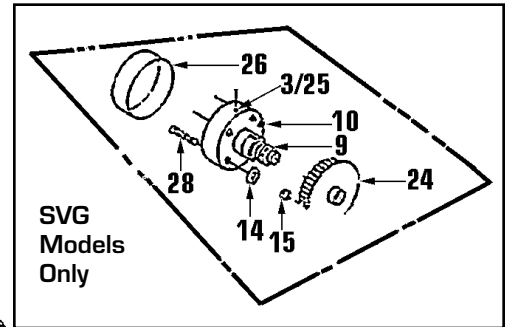
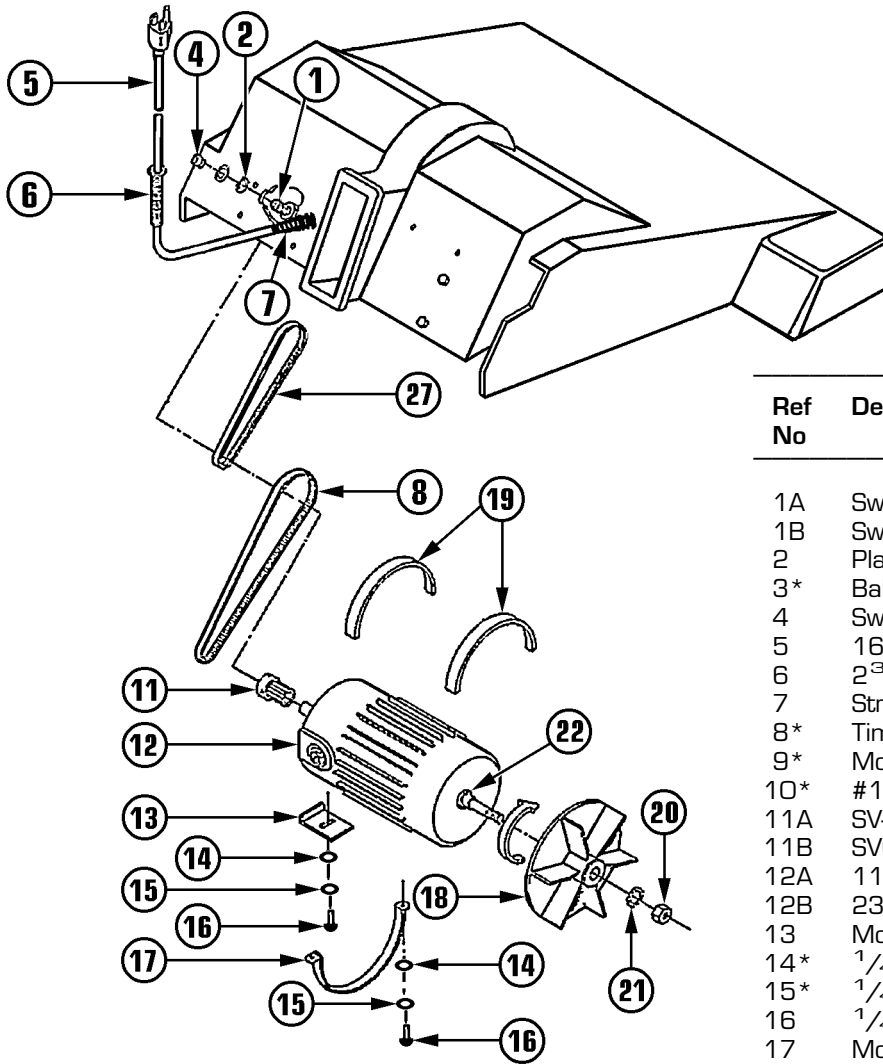

Ref No	Description	Qty	Part No
1A	Switch w/Terminal (115 Volt)	1	381012
1B	Switch w/Terminal (230 Volt)	1	382124
2	Plastic Spacer	1	381853
3*	Ball Bearings	2	315680
4	Switch Button Cover	1	381039
5	16/3 - 60 Ft Line Cord	1	381896
6	2 ³ / ₄ X 1 ¹ / ₂ " Spring	1	381160
7	Strain Relief	1	443379
8*	Timing Belt	1	315605
9*	Motor Drive Pulley	1	381209
10*	#10 - 24 X 1 ¹ / ₄ " Set Screw	2	380644
11A	SV-Series Motor Pulley	1	381209
11B	SVG-Series Motor Pulley	1	315621
12A	115 Volt Motor	1	381950
12B	230 Volt Motor	1	381535
13	Motor Clamp Bracket	2	381578
14*	1 ¹ / ₄ " Flat Washer	8	380652
15*	1 ¹ / ₄ " Lock Washer	4	342858
16	1 ¹ / ₄ - 20 X 5 ⁵ / ₈ " Hex Bolt	4	342831
17	Motor Clamp	1	381403
18	Fan Motor	1	457353
19	6" Strip Gasket	4	381640
20	1 ¹ / ₂ - 20 X 3 ³ / ₄ " Hex Nut	1	380776
21	Steel Tooth Washer	1	381780
22	Motor Seal 'V-Ring'	1	380563
23*	1 ¹ / ₄ - 20 Locknut	4	380784
24*	Timing Belt Pulley	1	315664
25*	Bearing Housing	1	315389
26*	Vinyl Cap	1	317152
27A	SV-Series Poly V Belt	1	381071
27B	SVG-Series Poly V Belt	1	315613
28*	1 ¹ / ₄ - 20 X 1 ¹ / ₂ " Screw	4	318914
29*	Keeper Ring (Not Shown)	1	315702
30*	Jack Shaft (Not Shown)	1	315397
31*	Jack Shaft Assembly (N/S)	1	316903
32*	Jack Shaft Assy w/Pulley (N/S)	1	344672
N/S	Motor Bearing - 115 Volt	1	382167
N/S	Carbon Brush - 115 Volt	1	382132

* SVG Vacuums only.

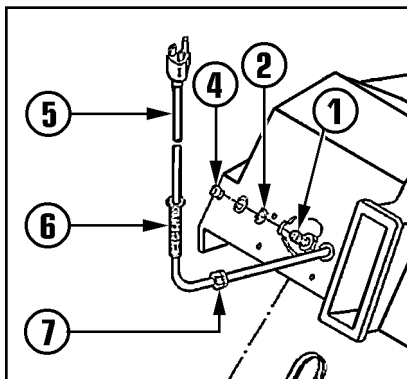

BRUSH & BODY

REPLACEMENT

PARTS LIST

Ref No	Part Description	Qty	Part No
1	1/4- 20 X 3/4" Screw	1	342831
2	Flat Washer	1	380652
3	1/4" Split Lockwasher	1	342858
4	1/4- 20 Nut	1	380881
5	8 -18 X 5/8" Screw	2	381799
6	Tinnerman	1	381616
7	#8 Int Tooth Lockwasher	6	380709
8	Tinnerman	1	380873
9	8 -18 X 5/8" Screw	2	381799
10A	SV-Series Belt Guard	1	381365
10B	SVG-Series Belt Guard	1	316881
11	10 - 24 X 1/2" Screw	2	380938
12	10 - 24 X 5/8" Screw	3	380997
13	Brush Bracket	1	381233
14	10-24 Nut Hex	2	381004
15A	SV200 - 20" Brush	1	381497
15B	SV240 - 24" Brush	1	268399
15C	SV280 - 28" Brush	1	267961
15D	SVG201 - 20" Brush	1	320420
15E	SVG241 - 24" Brush	1	268399
15E	SVG281 - 28" Brush	1	267961
16	8 - 18 X 1" Hi-Low Screw	4	388629
17	Brush Cap	1	381225
18	Felt Washer	2	381187
19	Double Seal Bearing	2	380849
20A	20" Brush Shaft	1	381462
20B	24" Brush Shaft	1	381276
20C	28" Brush Shaft	1	381470
21	8 - 18 X 1 1/4" Hi-Lo Screw	4	388637
22	Brush Pulley	1	381217
23	Dust Guard	1	381446
24	Reinforcing Plate	1	381500
25	Reinforcing Plate	1	381411
26A	20" Brush Strip	1	318493
26B	24" Brush Strip	1	318507
26C	28" Brush Strip	1	318515
27	Brush Strip Holder	2	317144
28	#10 - 24 X 1/2" Screw	2	385379
29	Burr Washer	4	369519
30	Nylon Flat Washer	4	361054
31	Baffle	1	381306
32	Thread Guard	1	381527
33A	SV200 - 20" Brush Assy	1	382310
33B	SV240 - 24" Brush Assy	1	382329
33C	SV280 - 28" Brush Assy	1	382337
33D	SVG201 - 20" Brush Assy	1	321095
33E	SVG241 - 24" Brush Assy	1	321052
33F	SVG281 - 28" Brush Assy	1	321141
34A*	20" Ft Nozzle Baffle Strip	1	317160
34B*	24" Ft Nozzle Baffle Strip	1	315419
34C*	28" Ft Nozzle Baffle Strip	1	317195

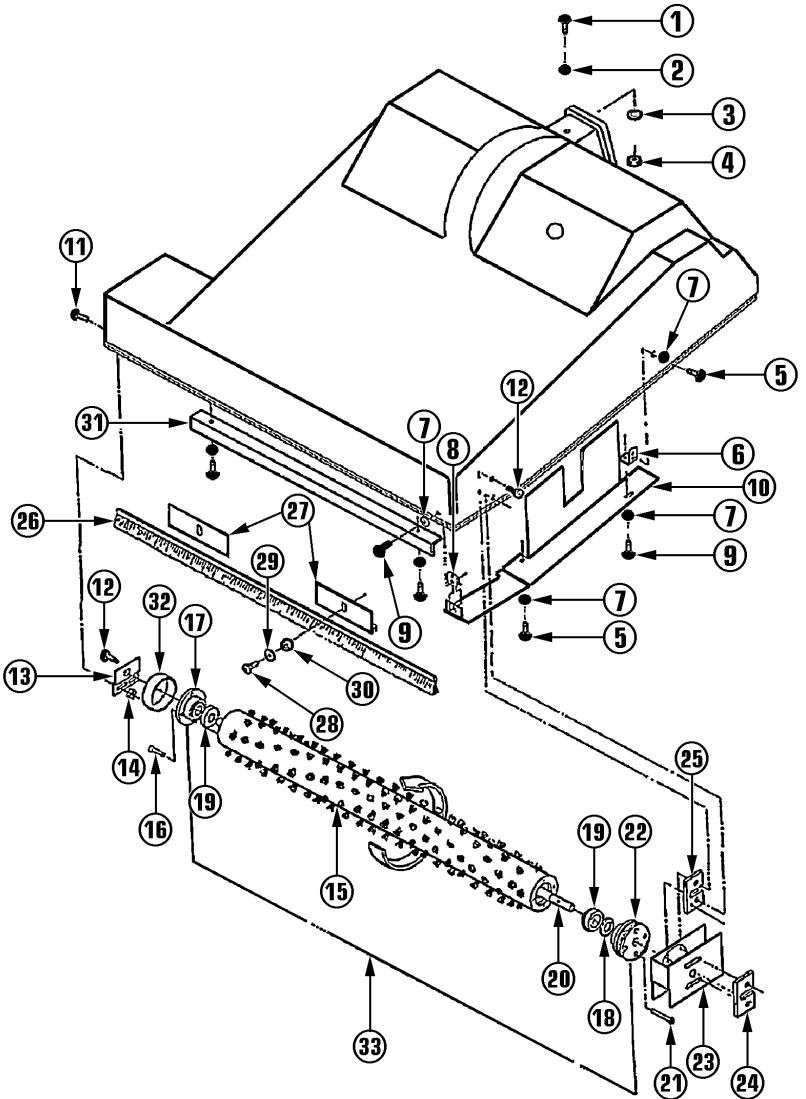

*Not Shown

CHASSIS REPLACEMENT PARTS LIST

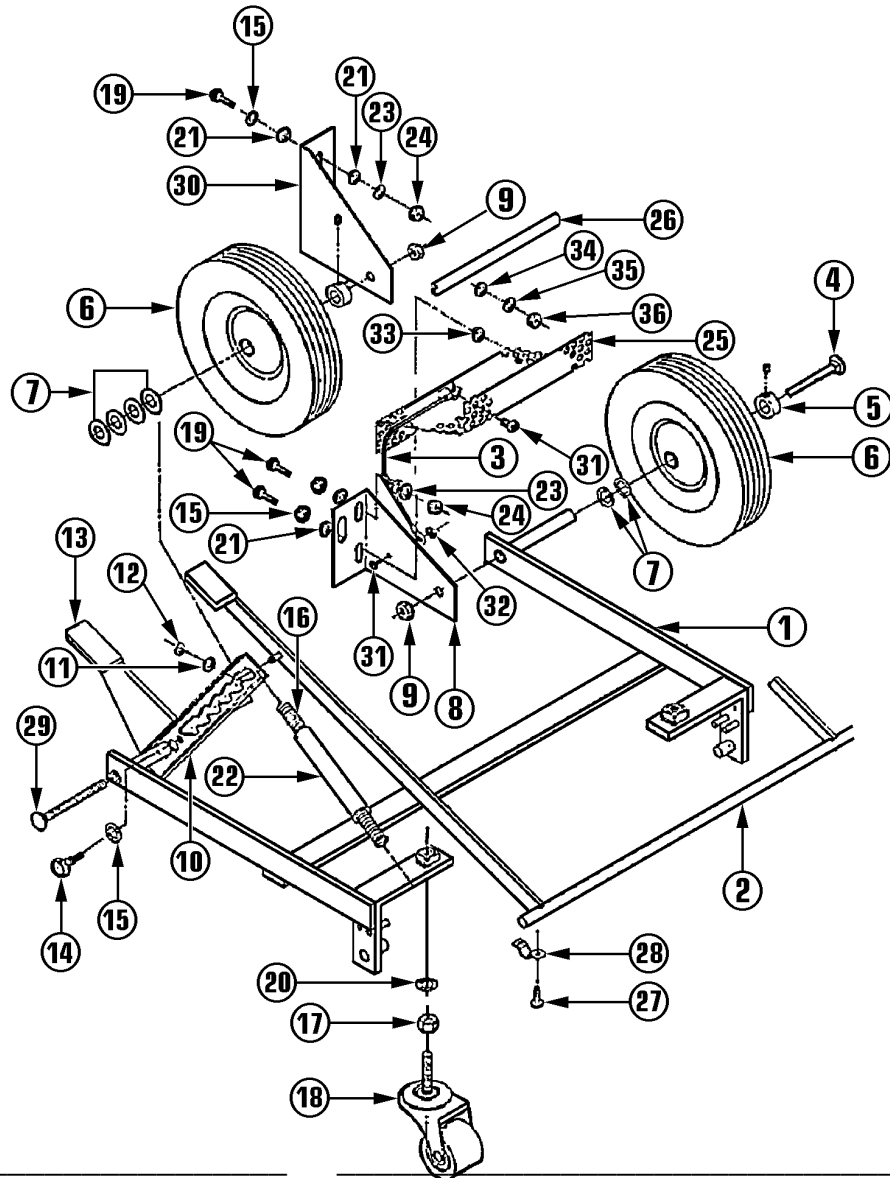

Ref No	Part Description	Qty	Part No	Ref No	Part Description	Qty	Part No
1	Frame Assembly	1	381357	18	1 ¹ / ₄ " Swivel Caster	2	381098
2	Linkage Assembly	1	381349	19	1 ¹ / ₄ - 20 X 7 ⁷ / ₈ " Screw	5	380857
3	Ground Lead w/Terminals	1	383031	20	Lockwasher	2	368849
4	3 ¹ / ₄ " Carriage Bolt	1	381748	21	Flat Washer	5	380652
5	Collar w/Set Screw	2	382035	22	4" Spring Tube	1	381756
6	5" X 1 ¹ / ₄ " Wheel	2	222607	23	1 ¹ / ₄ " Lockwasher	5	342858
7	Flat Washer	6	315435	24	1 ¹ / ₄ - 20 Nut	3	380881
8	Left Wheel Bracket	1	381292	25	Cover Assembly	1	381381
9	5 ⁵ / ₁₆ - 18 Lock Nut	2	380792	26	3" Bumper	1	381438
10	Ratchet Plate	1	381179	27	#8 - 5 ⁵ / ₈ " Hi-Lo Screw	2	434892
11	Flat Brass Washer	1	380679	28	Linkage Retainer	1	381241
12	Retaining Ring	1	381020	29	4 ¹ / ₄ " Carriage Bolt	1	381721
13	Height Adjustment Pedal Kit (Includes 10, 14 & 15)	1	381322	30	Right Wheel Bracket	1	381284
14	1 ¹ / ₄ - 20 X 3 ³ / ₈ " Screw	2	380903	31	6 - 32 X 3 ³ / ₈ " Screw	2	377155
15	Int Tooth Washer	2	380695	32	6 - 32 Hex Nut	1	377171
16	Adjustment Pedal Spring	1	382043	33	Spacer	5	322660
17	3 ³ / ₈ - 16 Nut	2	380741	34	1 ¹ / ₄ " Flat Washer	7	380652
				35	1 ¹ / ₄ " Lockwasher	5	342858
				36	1 ¹ / ₄ - 20 Hex Nut	2	338966

BAG ADAPTOR AND BUMPER REPLACEMENT PARTS LIST

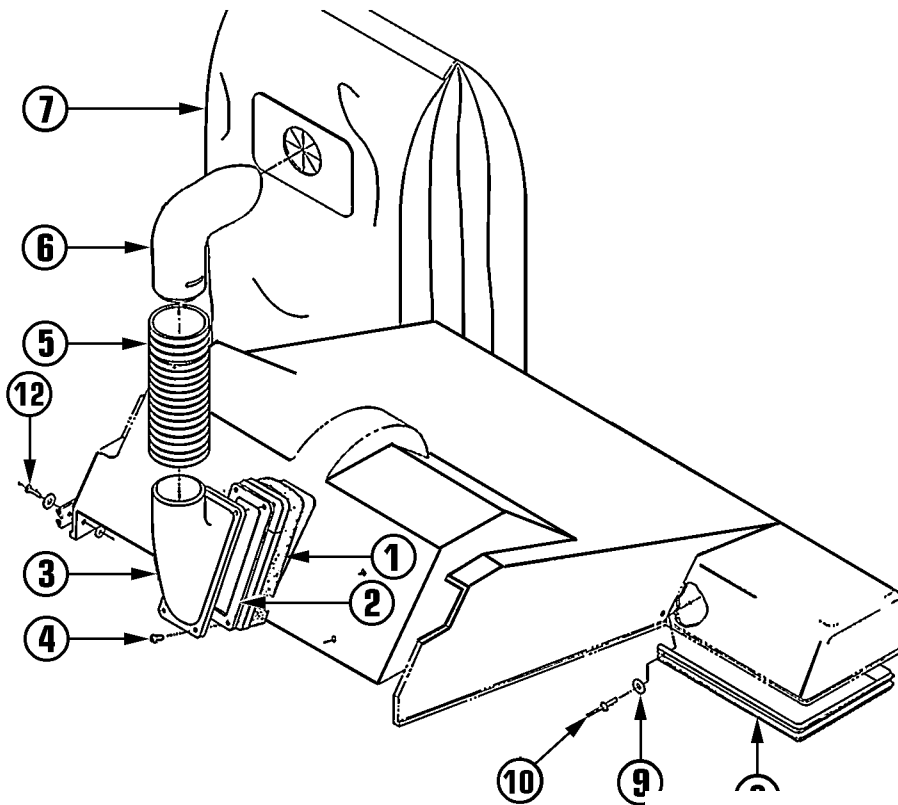

Ref No	Part Description	Qty	Part No
1	Flat Gasket	1	381551
2	Flat Gasket	1	385492
3	Hose Adaptor	1	385468
4	10 X $\frac{5}{8}$ " Hi-Lo Screw	4	306606
5	2 $\frac{1}{2}$ " Dia X 3" Hose	1	321036
6	Bag Adaptor	1	384674
7	Disposable Paper Bag (5 Pk)	1	332844
8	Bumper	1	441627
9	Steel Washer	4	369519

TROUBLE SHOOTING GUIDE



CAUTION:

Disconnect power before servicing vacuum.

PROBLEM: *Vacuum motor does not run.*

POSSIBLE CAUSE:

1. Broken or loose belt.
2. Brush seized with nap or strings.
3. Motor failure.

POSSIBLE SOLUTION:

1. Replace or retighten belt.
2. Clean bearings and brush of debris.
6. Contact manufacturer or service center.

PROBLEM: *Loss of vacuum.*

POSSIBLE CAUSE:

1. Loose or broken fan.
2. Motor failure.
3. Broken housing.
4. Full paper filter bag.

POSSIBLE SOLUTION:

1. Contact manufacturer or service center.
2. Contact manufacturer or service center.
3. Contact manufacturer or service center.
4. Replace filter bag.

PROBLEM: *Motor will not run.*

POSSIBLE CAUSE:

1. Broken switch.
2. Damaged line cord.
3. Damaged motor

POSSIBLE SOLUTION:

1. Contact manufacturer or service center.
2. Contact manufacturer or service center.
3. Contact manufacturer or service center.

PROBLEM: *Dust blowing from vac when running.*

POSSIBLE CAUSE:

1. Full paper filter bag.
2. Paper filter bag not installed or off adaptor.
3. Cloth filter bag dirty.

POSSIBLE SOLUTION:

1. Replace paper filter bag.
2. Reinstall paper bag.
3. Clean cloth filter bag

PROBLEM: *High pitched whine.*

POSSIBLE CAUSE:

1. Loose belt.
2. Broken or chipped fan.

POSSIBLE SOLUTION:

1. Tighten belt.
2. Contact manufacturer or service center.

Mastercraft

Address:

777 South Street
Newburgh, N Y 12550-0606

TEL:

(800)835-7812
(845)565-8850

FAX:

(800)752-6883
(845)565-9392

URL:

www.mastercraftusa.com

E-Mail:

mail@mastercraftusa.com



WARNING:

Repairs should only be performed by an authorized service center.