

**Ambassador
Junior
International
240V**

Model: C45014-02

OPERATION

SERVICE

PARTS

CARE

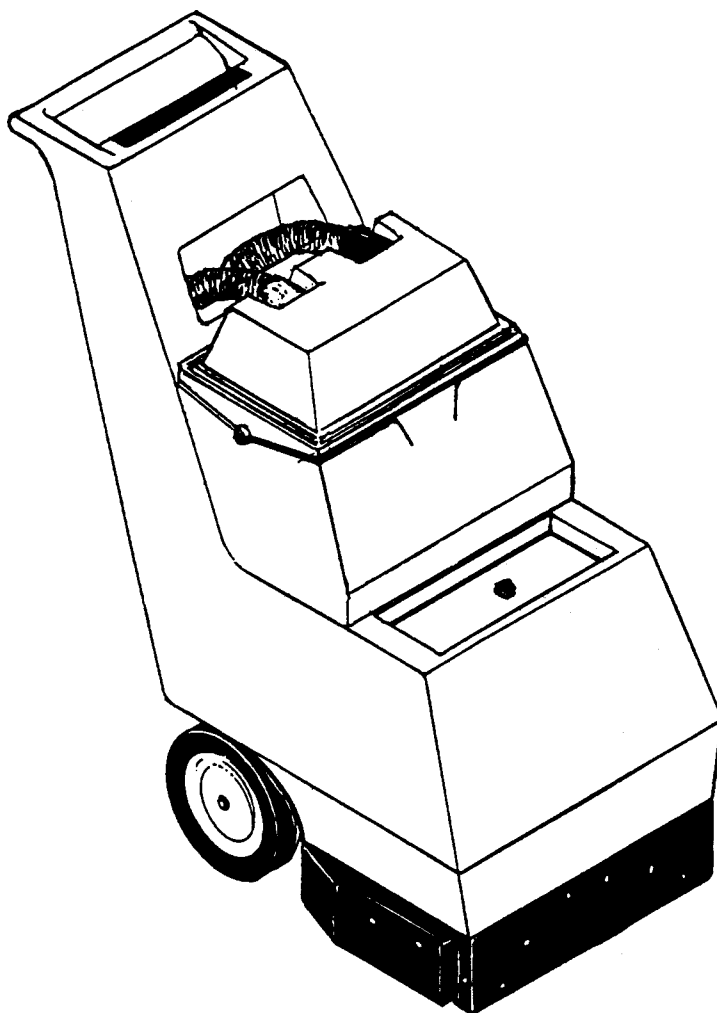

Revised 4/04

Minuteman[®]

FOR COMMERCIAL USE ONLY

IMPORTANT SAFETY INSTRUCTIONS

When using an electrical appliance, basic precautions should always be followed, including the following:

READ ALL INSTRUCTIONS BEFORE USING

WARNING - To reduce the risk of fire, electric shock, or injury:

- Do not leave appliance when plugged in. Unplug from outlet when not in use and before servicing.

WARNING

To reduce the risk of electrical shock, do not expose to rain. Store indoors.

- Do not allow to be used as a toy. Close attention is necessary when used by or near children.
- Use only as described in this manual. Use only manufacturer's recommended attachments.
- Do not use with damaged cord or plug. If appliance is not working as it should, has been dropped, damaged, left outdoors, or dropped into water, return it to a service center.
- Do not pull or carry by cord, use cord as a handle, close a door on cord, or pull cord around sharp edges or corners. Do not run appliance over cord. Keep cord away from heated surfaces.
- Do not unplug by pulling on cord. To unplug, grasp the plug, not the cord.
- Do not handle plug or appliance with wet hands.
- Do not put any object into openings. Do not use with any opening blocked; keep free of dust, lint, hair, and anything that may reduce air flow.
- Keep hair, loose clothing, fingers, and all parts of body away from openings and moving parts.
- Do not pick up anything that is burning or smoking, such as cigarettes, matches, or hot ashes.
- Do not use without dust-bag and/or filters in place.
- Turn off all controls before unplugging.
- Use extra care when cleaning on stairs.
- Do not use to pick up flammable or combustible liquids such as gasoline or use in areas where they may be present.
- Connect to a properly grounded outlet only. See grounding instructions.

SAVE THESE INSTRUCTIONS

INSPECTION

Carefully unpack and inspect your machine for shipping damage. Each unit is tested and thoroughly inspected before shipment, and any damage is the responsibility of the delivery carrier who should be notified immediately.

ELECTRICAL

This machine is designed to operate on a standard 16 amp. type L fused 230 volt, 50 hz, AC circuit. Voltages below 200 volts AC or above 250 volts AC could cause serious damage to the motor. I.E.C. Class 1.

WARNING

Electric motors can cause explosions when operated near explosive materials or vapors. Do not operate this machine near flammable materials such as solvents, thinners, fuels, grain dust, etc.

GROUNDING INSTRUCTIONS

This appliance must be grounded. If it should malfunction or breakdown, grounding provides a path of least resistance for electric current to reduce the risk of electric shock. This appliance is equipped with a cord having an equipment-grounding conductor and grounding plug. The plug must be plugged into an appropriate outlet that is properly installed and grounded in accordance with all local codes and ordinances.

DANGER

Improper connection of the equipment-grounding conductor can result in a risk of electric shock. Check with a qualified electrician or service person if you are in doubt as to whether the outlet is properly grounded. Do not modify the plug provided with the appliance — if it will not fit the outlet, have a proper outlet installed by a qualified electrician.

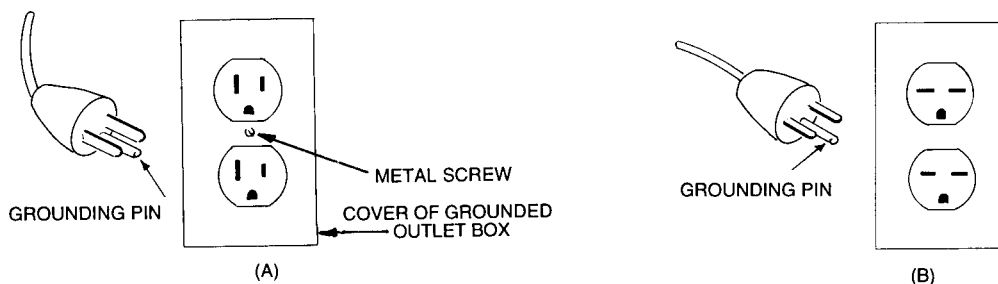

USER MAINTENANCE INSTRUCTIONS

All service and repair should be performed by qualified vacuum service representative or electrician. No user serviceable components are employed in the electrical system. No lubrication of the motor is required.

DAILY MAINTENANCE

1. Solution tank should be emptied after each use. Flush pumping system with 2 or 3 gallons of clean hot water.
2. Check and clean vacuum inlet filter (page 7, item 118) and solution inlet strainer (page 7, item 1) daily.
3. Removable recovery tank, page 7, item 40, should be rinsed clean daily.
4. Spray jets should be checked for correct spray pattern and cleaned if plugged (page 7, item 55). Spray jets are quick release 1/4 turn type. By twisting item 121 1/4 turn counter clockwise, jets can be removed for cleaning. Do not clean out spray tips with pins or wire, this may cause damage to the jet spray pattern and cause streaking.
5. Protect equipment from freezing. Severe pumping system damage can occur if allowed to freeze.
6. Inspect vacuum hoses for tight connections. Check electrical cable for abrasion or cuts in jacket. Cord should be replaced if worn or damaged.

MONTHLY/BI-MONTHLY MAINTENANCE

The Ambassador Solution Pump System should be purged twice monthly to remove alkaline residue build-up. The system should be flushed twice, once with the jets installed and once with jets removed. To flush system out, use 1 quart of white vinegar to two gallons of clean hot water, followed by a clear 2 gallon rinse. Clean spray jets if required.

CORD STORAGE

While not in use storage can be accomplished by winding cord around rear of machine. Cord hooks are provided.

- Do not use with damaged cord or plug. If appliance is not working as it should, has been dropped, damaged, left outdoors, or dropped into water, return to service center.
- Do not pull or carry by cord, use cord as handle, close a door on cord, or pull cord around sharp edges or corners. Do not run appliance over cord. Keep cord away from heated surfaces.
- Do not unplug by pulling cord. To unplug, grasp the plug, not the cord.
- Do not handle plug or appliance with wet hands.

This equipment should be stored indoors and not exposed to rain.

OPERATING INSTRUCTIONS

FILLING THE AMBASSADOR

Remove clear solution cover lid from front of machine, page 7, item 32. Fill solution tank with desired amount of warm water and add liquid cleaning chemical, Minuteman Extraction Shampoo order #902163. (See instructions on container for proper dilutions.) DO NOT USE powdered cleaning chemicals. Powders are unlikely to dissolve thoroughly, resulting in clogging the inline solution strainer. This can reduce or stop solution flow to the pump and spray jets.

Carpet should be thoroughly vacuumed and obstacles relocated before beginning the cleaning cycle. Heavy traffic lane areas should be pre-treated or spotted with Minuteman Pre-Treat order #902183 for best results.

TO BEGIN CLEANING:

1. Always work away from the cord.
2. Machine operates by pulling backwards over carpet.
3. Vacuum Lid Assembly (page 7) should be properly seated on Recovery Tank (item 40) for proper vacuum recover. See figure 3 for hose hookup.
4. See page 5, Control Panel Switch Identifications: Normal Cleaning Mode
 1. Turn on vacuum switch (1).
 2. Turn on brush switch (2).
 3. Turn on pump switch to continuous (3).
 4. Adjust brush pressure (figure 2) at rear of machine, until brush pressure gauge reads in green zone.
 5. Solution pump should be turned off to the center switch position, page 5 (4), 6" before the end of each cleaning pass.

During the cleaning cycle, care should be taken not to allow foam to build up in the recovery tank. If this should happen, the machine should be turned off. Defoamer order #910543 should be added to the recovery tank only, never into the solution tank. Foam should not be allowed to enter vacuum filter screen.

The recovery waste water level can be viewed from the operator's position of the machine through the visible recovery dome. When waste water is within 2" of the top of the recovery tank, the tank should be emptied. (NOTE : Never tilt machine completely back with recovery tank in place. Always remove tank and set to the side before tilting complete machine.) Recovery tank can be emptied by lifting visible recovery dome and lifting out tank by front handle. A handle gripping area is provided in the front bottom of the recovery tank to tilt and pour the waste water out.

AUXILIARY TOOL HOOK UP

1. Remove grey hose fitting from clear recovery dome and install auxiliary hose assembly cuff to grey fitting by passing through rear of machine. Hook up solution hose to auxiliary out coupler at rear of machine.
2. Turn vacuum switch to on.
3. Turn pump auxiliary switch to on (page 5, item 6). All other switches should be off.

OPERATOR VIEW OF CONTROL PANELS

1. Vacuum switch
2. Brush switch
3. Pump spray switch, continuous operation position. Pump supplies solution to spray bar for cleaning in large open areas.
4. Center position is "off".
5. Momentary position is for intermittent spray for cleaning in smaller more confined areas. When released, switch will return to center off position.
6. Pump auxiliary when using separated floor tool or upholstery tool, switch must be switched to on position. See figure 2 for solution hose hook up - aux. out.
7. Brush pressure adjustment gauge.

See figure 2 for brush adjustment knob location. Adjustments past the green zone on gauge will shorten brush and brush drive motor life.

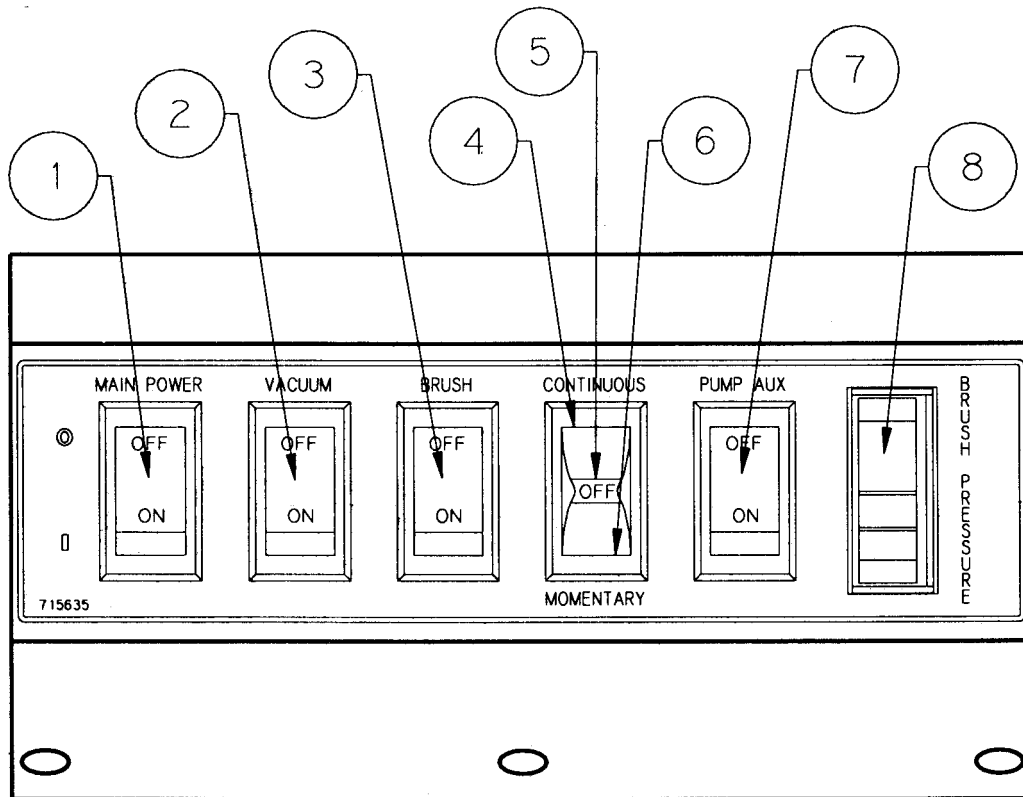

FIG. 1

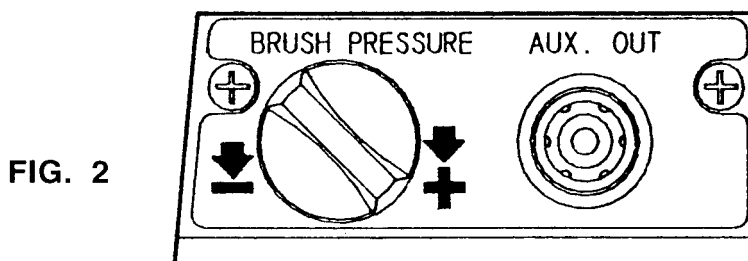
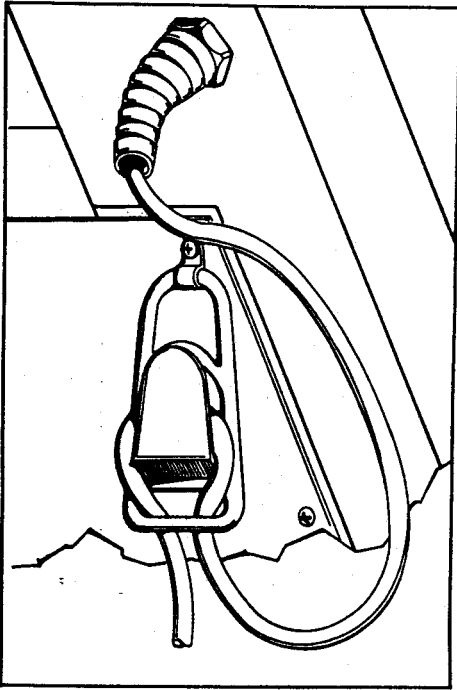
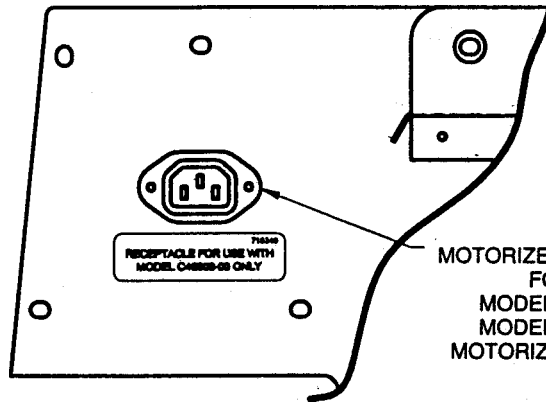

FIG. 2

CORD STRAIN RELIEF



PARTIAL VIEW BACK PANEL



MOTORIZED TOOL RECEPTACLE
FOR USE WITH
MODEL C46300-00 (120V)
MODEL C46300-02 (240V)
MOTORIZED TOOL USE ONLY!

OPERATOR VIEW VISIBLE RECOVERY SYSTEM

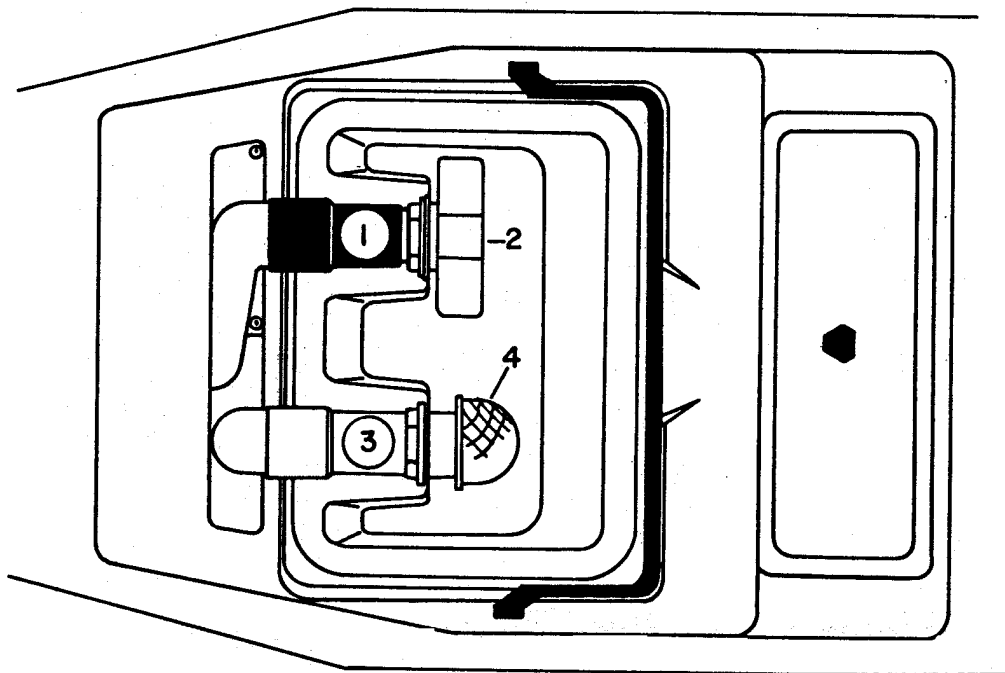
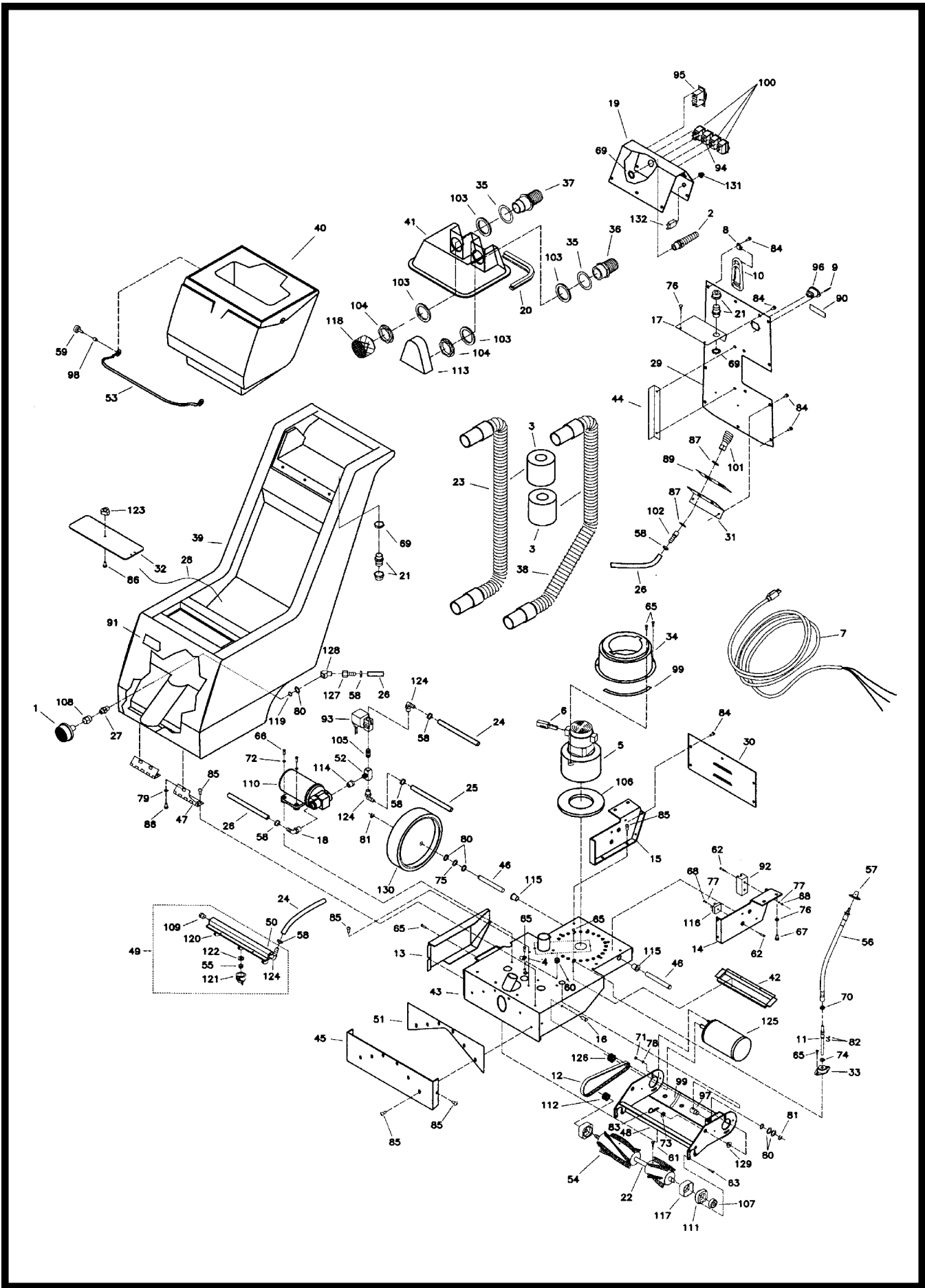

FIG. 3

1. Waste Water Recovery Hose
(Grey hose cuff to grey fitting)
2. Recovery Waste Water Diffuser
3. Vac Hose White Cuff
(White hose cuff to white fitting)
4. Vac Filter Screen



PARTS LIST

Item	Part #	Qty.	Description	Item	Part #	Qty.	Description
1	130118	1	Solution Strainer M3-40	67	711202	2	BLT-HH 1/4-20 x .50 ST PL
2	150004	1	Relief Strain Heyco 3251	68	711301	3	Nut-Hex 6-32 ST PL
3	169125	2	Filter 1.44 x 3.5 x 3	69	711400	3	Nut-Pipe Lock 1/2
4	250038	1	Retainer, Bag Clip	70	711420	3	Nut-Hex Jam 5/16-18 ST PL
5	740244	1	Vac Motor 117396-07 240V	71	711427	2	Nut-Flanged Wizz 10-32
6	380028	2	Carbon Brush Replacement	72	711503	4	WSR-Flat #10
7	740600	1	Cord European F3G1.5MM 50ft BLK	73	711506	2	WSR-Flat (Narrow) 5/16 ST PL
8	381052	1	Clamp Plastic 3/8 ID	74	711523	1	WSR-Wave .37 x .68 x .08
9	410-4419AA	2	Rivet Pop	75	711524	3	WSR-Wave .52 x .87 x .01
10	450012	1	Cord Strain Relief	76	711544	2	WSR-Helical 1/4
11	450019	1	Adj. Rod Brush	77	711552	3	WSR-Internal Lock #8
12	450022	1	Belt-Brush 399-3M-06K	78	711553	7	WSR-Internal Lock #10
13	450026	1	Belt Guard SC17 PTD	79	711554	4	WSR-Internal Lock 1/4 ID
14	450030	1	Wheel Well Plate RH	80	711594	11	WSR-Flat .56 x .88 x .02 NI
15	450031	1	Wheel Well Plate LH	81	711713	3	Ret Ring - E Ext. .50
16	450034	2	Pin Clevis 5/16 x .75	82	711717	2	Ret Ring - E Ext. .37
17	450036	1	Cover Top AMB 17	83	711808	2	Pin - Cotter Hairpin #13
18	450040	1	Elbow PLT 3/8 MPT x 3/8 Barb	84	712101	19	SCR-MC HWSR 10-24 x .375 SS
19	450043	1	Dashboard	85	712559	16	SCR-TR 1/4-20 x .62 TORX TR HD SEMS
20	450044	1	Molded Recovery Dome Gasket	86	712560	5	SCR-MCH 1/4-20 x .50 SS NYLOC
21	450050	2	Bushing Heyco .875 x .875 x 1.	87	712760	2	WSR-FLT .56 x 1.06 x .04 SS
22	450052	1	Brush Shaft Amb. Jr	88	715132	1	Decal Dashboard Diecut
23	450053	1	Vac Hose Assy. White SC17	89	715133	1	Decal Brush Adjustment Ambassador
24	450055	2	Hose Nylo 3/8 ID x 9"	90	715341	1	Decal Receipt 230V
25	450056	1	Hose Nylobraid C/L 21"	91	715385	1	Decal MMN 1.4 x 9.68 Lt Gry
26	450057	1	Hose 3/8 ID x 20.5	92	740189	1	Terminal Block-10471
27	450059	1	Fitting Brass 1/4 MPT 1/4 MPT	93	740240	1	Water Solenoid 240V 50HZ
28	450062	1	Cord Nylon C/L 12"	94	740400	1	Switch Momentary 15AMP
29	450063	1	Back Panel Assy Amb Jr	95	740229	1	Gauge Brush Pressure 0-1.5
30	450064	1	Lower Rear Panel	96	741038	1	Receptacle-IEC 320
31	450065	1	Bracket Quick Disconnect	97	762257PLT	1	Nut, Adjusting RH Zinc Dicromate
32	450066	1	Solution Lid Cover	98	762384	2	Bushing .277 x .375 x .37 SS
33	450068	1	Bearing, Flange Mounted	99	805042	1	Gasket
34	450074PLT	1	Motor Shroud Zinc Plated	100	809754	3	Switch Rocker
35	450081	2	WSR 1.908 x 2.41 x .03 SS	101	828370	1	BH2-60 Female Coupler
36	450082	1	Insert Fit TA 102424 Grey	102	828952	2	Fitting PP1/4 MPT 3/8 Barb
37	450083	1	Insert Fit TA 102424 White	103	828970	4	WSR Neoprene 1.87 x 2.4 x .125
38	450090	1	Recovery Hose New Style	104	828971	2	Nut 1 1/2 Pipe Thread
39	450100MCH	1	Solution Tank Jr Burgundy	105	828981	1	Fitting Brass Nipple 1/4MPT
40	450101B	1	Tank Recovery Jr Burgundy	106	828995	1	Gasket Neop 2.5 x 6 x .62
41	450102	1	Recovery Dome Amb Jr	107	829044	2	Bearing-Brush .3937 x 1.1811
42	450104	1	Vacuum Air Manifold	108	829114	1	Adapter BR 3/8 FPT x 1/4 FPT
43	450106	1	Mainframe Weldment	109	829619	1	Hex Head Pipe Plug 1/4 B
44	450109	1	L Bracket Back Panel 450063	110	742150	1	Pump 230V Bypass
45	450110	1	Front Squeegee Plate	111	829758	2	Bearing Block
46	450111	1	Axle Rear Amb Jr	112	829823	1	Pulley HTD Flanged 30T
47	450112	2	Hinge Amb Jr	113	830448	1	Deflector
48	450113	1	Brush Bracket Weldment	114	830708	1	Bushing BR 3/8 MPT x 1/4 FPT
49	450116	1	Spray Tube Assy Amb Jr	115	831212	2	Flange Bearing
50	450117	1	Spray Tube PVC	116	740203	1	Rectifier-Bridge 50A 1000V
51	450118	1	Front Plate Neoprene Gasket	117	831610	2	Brush Shield
52	450119	1	Male Branch T 1/4 Brass	118	831621	1	Filter-Dome Vac 1.5 #10
53	450120PTD	1	Handle Recovery Tank Amb	119	832326	1	O Ring
54	450121	1	Brush Core Amb. Jr ASR	120	833140	3	Body Inlet Connector
55	450122	3	Unijet Spray Tip 6503	121	833141	3	Cap
56	452010	1	Cable Flexible Assembly	122	833142	3	Gasket, Cap
57	452029	1	Knob 1520 x BLK 1/4 BRAS	123	833214	1	Knob 3-Sided 1/4 20 INSE
58	452037	4	Clamp Crimp 170R SS	124	833325	3	Fitting Nylon 90 1/4MPT 3/8HOS
59	500033	2	Locking Screw	125	833458	1	PM Motor 1/8 HP 230V
60	700287	1	Grommet	126	833443	1	HTD Flanged Pulley 22 T.
61	710130	2	SCR-MC 8-32 x .62 Nickel	127	833473	1	Fitting Brass 1/4 FPT 3/8 Hose
62	710207	3	SCR-MC 6-32 x .87 ST PL	128	833906	1	Fitting Brass 45 1/4MPT 1/4 FPT
63	710528	8	SCR-MC 8-32 x .37 BR	129	840202	2	Bushing-FLG .314 x .825 x .385
64	711104	2	SCR-ST-A 10 x .50	130	900008	2	8.00 Dia. Wheel
65	711124	11	SCR-ST-B 10 x .37 NI	131	740503	1	Switch-Boot N1.480-16ETA
66	711126	4	SCR-ST-B 10 x .75	132	740505	1	Circuit Brkr-1.5 amp ETA 41-06-P10

RECEPTACLE IEC 320
741038

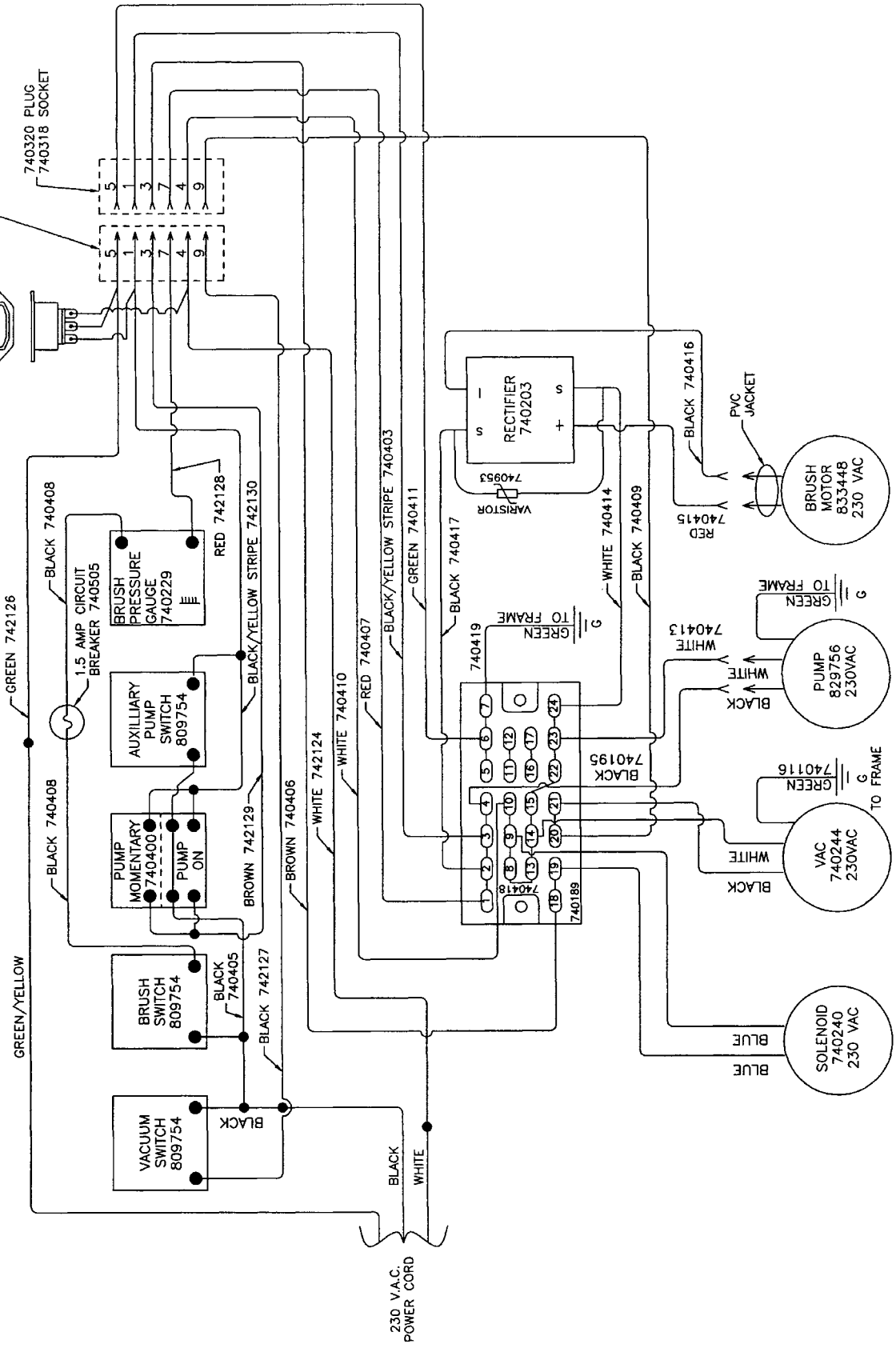
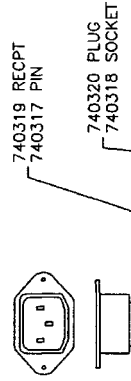

Recommended Carpet Care Chemicals

	Product #		Product #
Extraction Shampoo A highly concentrated low-foaming product. Contains detergents, emulsifiers, water-soluble solvents and optical brighteners for effective use in all types of carpet extraction equipment.	902163	Back to 7 A mild acid formula that neutralizes alkaline residues and removes browning and de-icing salt residues.	902053
Pre-Treat A synthetic cleaner formulation used as a pre-spray to help speed the cleaning action of the shampoo process. Use for bonnet cleaning and also as an effective spotter.	902183	Take Charge An effective, safe long lasting product designed to eliminate troublesome static electricity from carpet.	910033
Take-Out An enzyme detergent spotter that dissolves protein carbohydrates, cellulose, vegetable oils, greases and both human and pet urine stains.	902198	Karpetreet II™ Contains DuPont "Teflon" carpet protector. A water-based, concentrated fluoro-chemical which forms a protective coating that inhibits resoiling of carpet.	902153
Carpet Spotter A water-based spotter which contains organic solvents for use on spots created by material such as grease, tar and crayons	910678	SpinShield Cleans and provides oil stain repellency to carpets in one step when spin-bonnet cleaning.	902073
Defoamer A silicone-based defoamer for use in any cleaning equipment which generates foam.	910543	ExtracShield An effective detergent system formulated with an optical brightener and carpet fiber protectant for use with hot water extraction equipment.	902063
Odor-Out A concentrated water-based deodorant additive that can be sprayed, mopped or wiped on any surface that is not harmed by water.	902143	Carpet Spotting Kit Contains five specialized carpet spot removers formulated to remove a wide assortment of stains from commercial and institutional carpeting. An easy to follow, color coded spotting guide simplifies effective spot removal with step-by-step instructions.	902000

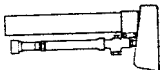
		Part No.	Description
A		828924	Hose Assembly
B		831255	Scrub Wand
C		390070	Stair & Upholstery Tool

LIMITED WARRANTY

Minuteman International, Inc. warrants to the original purchaser/user that this product is free from defects in workmanship and materials under normal use and service for a period of three years from date of purchase. In addition, Minuteman International, Inc. will, at its option, honor labor warranty claims for the first 12 months from date of sale, provided such claims are submitted through and approved by factory authorized repair stations. Minuteman International, Inc. will, at its option, repair or replace without charge, except for transportation costs, parts that fail under normal use and service when operated and maintained in accordance with the applicable operation and instruction manuals.

This warranty does not apply to normal wear, or to items whose life is dependent on their use and care, such as belts, cords, switches, hoses, rubber parts, electrical motor components or adjustments. Parts not manufactured by Minuteman International, Inc. such as engines, batteries, battery chargers, hydraulic pumps, and tires are covered by and subject to the warranties and/or guarantees of their manufacturers. Please contact Minuteman International, Inc. for procedures in warranty claims against these manufacturers.

Special warning to purchaser — Use of replacement filters and/or prefilters not manufactured by Minuteman International, Inc. or its designated licensees, will void all warranties expressed or implied.

A potential health hazard exists without exact original equipment replacement.

All warranted items become the sole property of Minuteman International, Inc. or its original manufacturer, whichever the case may be.

Minuteman International, Inc. disclaims any implied warranty, including the warranty of merchantability and the warranty of fitness for a particular purpose. Minuteman International, Inc. assumes no responsibility for any special, incidental or consequential damages.

This limited warranty is applicable only in the U.S.A. and Canada, and is extended only to the original user/purchaser of this product. Customers outside the U.S.A. and Canada should contact their local distributor for export warranty policies. Minuteman International, Inc. is not responsible for costs or repairs performed by persons other than those specifically authorized by Minuteman International, Inc. This warranty does not apply to damage from transportation, alterations by unauthorized persons, misuse or abuse of the equipment, use of non-compatible chemicals, or damage to property, or loss of income due to malfunctions of the product.

If a difficulty develops with this machine, you should contact the dealer from whom it was purchased.

This warranty gives you specific legal rights, and you may have other rights which vary from state to state. Some states do not allow the exclusion or limitation of special, incidental or consequential damages, or limitations on how long an implied warranty lasts, so the above exclusions and limitations may not apply to you.

Minuteman[®]

World Headquarters
Minuteman International, Inc.
111 South Rohlwing Road
Addison, Illinois 60101

Minuteman Canada, Inc.
2210 Drew Road
Mississauga, Ontario
L5S 1B1

(630) 627-6900
FAX (630) 627-1130

(905) 673-3222
FAX (905) 673-5161

985808-I
Printed in U.S.A.