



Predator CXC and CXH Spotter

*INFORMATION
&
OPERATING
INSTRUCTIONS*

**READ AND UNDERSTAND THESE INSTRUCTIONS
BEFORE OPERATING THE MACHINE**

CONTENTS:

Machine Specifications	2	Care & Maintenance	4
Record Important information:	2	Views of Machine.	5
Safety Information & Cautions	3	Set up & Operating Instructions	6
Your New Machine	4	CXC Part List & Schematic	7
Normal Use	4	CXH Part List & Schematic	8
Chemicals	4	Troubleshooting.	9
Tools & Accessories	4	Notes	10

MACHINE SPECIFICATIONS:

	CXC	CXH
Pump	55 psi, oscillating	55 psi, oscillating
Vacuum	2-stage, 90" lift, 97 cfm	2-stage, 90" lift, 97 cfm
Heater	N/A	750 watt
Solution Tank Capacity	2.5 Gal	2.5 Gal
Recovery Tank Capacity	2 Gal	2 Gal
Vacuum Shut-off	Ball Float	Ball Float
Dimensions	28 -5/16"H X 11-1/8" W X 15-1/2" L	28-5/16" H X 11-1/8" W X 15-1/2" L
Weight	22 lbs	24 lbs

MACHINE AND PURCHASE INFORMATION:

RECORD AND RETAIN THIS IMPORTANT INFORMATION

Serial Number: _____

Model: CXC CXH

Purchase Date: _____

Write the name and phone number of your distributor:

And don't forget to register your purchase to activate your warranty

CRITICAL SAFETY INFORMATION & CAUTIONS

The acceptable use of this machine is for commercial/professional cleaning, for example, in hotels, schools, hospitals, offices and automobiles rather than for personal housekeeping.

NOTE: Read all instructions before using this machine. Improper use or misuse of the machine can result in personal or property damage.



READ ALL!

WARNING!



To reduce the risk of personal injury or property damage, follow these procedures:

- Connect to a properly grounded outlet only.
- Do not operate the machine in an explosive environment.
- Do NOT use Solvents.
- Never add water over 120° F/49 °C to the solution tank.
- Do not pick up anything that is burning or smoking, such as cigarettes, matches, or hot ashes, or any health endangering dusts. Do not use to pick up flammable or combustible liquids such as gasoline or use in areas where they may be present.
- To avoid electric shock, do not expose to rain or snow and keep from extremes in temperature. Store in a heated location. Use the machine indoors. Do not use outdoors.
- Do not use with damaged cord or plug. If the machine is not working as it should, has been dropped, damaged, left outdoors or flooded with water, return it to a service center.
- Do not use this machine to dry vacuum before wet cleaning.
- Do not leave the machine unattended when it is plugged in. Unplug the unit from the outlet when not in use and before servicing.
- Do not allow to be used as a toy. Close attention is necessary when used near children.
- Use only as described in this manual. Use only the manufacturer's recommended attachments.
- Do not handle the plug, the cord, or the machine with wet hands.
- Extension cords must be 14/3 and no longer than 50 feet. Replace the cord or plug immediately if the ground prong becomes damaged.
- Do not put any object into openings. Do not use with any opening blocked; keep free of dust, lint, hair, and anything that may reduce air flow.
- Keep loose clothing, hair, fingers, and all parts of body away from openings and moving parts.
- Liquid ejected at the spray nozzle could be dangerous as a result of its temperature, pressure, or chemical content

READ AND SAVE THESE INSTRUCTIONS

YOUR NEW MACHINE:

The manufacturer thoroughly tests every machine it sells before it is packaged. When you receive your new machine, examine the packaging for signs of shipping damage. Carefully unpack the machine and inspect it. If you see evidence of damage to the container or the contents, contact the freight carrier immediately.

Additionally, ensure all parts and accessories are present; if you notice anything missing, contact your distributor without delay.

NORMAL USE:

The CXC & CXH Spotters are designed to clean small areas like furniture, area rugs, and spots in carpets. These machines are not suited for cleaning the carpet in an entire room.

CHEMICALS:

The use of clear water in the machine is recommended, with the use of properly diluted cleaner applied as a pre-spray on the area to be cleaned; however, you may mix water and cleaning chemicals in a bucket -- according to directions on the chemical label -- and then pour into the solution tank. If you chose to use chemicals in the machine, always use a cleaner with a pH as close to neutral as possible to avoid premature wear of the pump, seals, and/or other components. Damage caused by the use of strong chemicals is not covered by the warranty.

The use of powder chemicals is discouraged; unless they are mixed very thoroughly and rinsed out completely at the end of the job, powdered cleaners could cause a build-up in the pump, lines, heater and/or quick disconnects. Any problem caused by a chemical build-up is not covered by warranty.

If foaming occurs as you clean, use a defoamer, either in the recovery tank or on the area being cleaned, to prevent overflow which can cause water damage.

TOOLS & ACCESSORIES:

Use only manufacturer's recommended tools and accessories. The hand tool is made from stainless steel and will provide years of trouble-free use. If the spray valve begins to leak or if the spray tip gets worn and is no longer providing a nice even spray pattern, order a replacement part from your distributor.

The solution line and vacuum hose are made of durable and long-lasting components and, with proper care, they both should last for years. Use a spray silicone to keep the quick connect couplings moving freely.

CARE & MAINTENANCE:

For optimum performance flush the machine with clear water at the end of each working day. Once a month, minimum, run a flushing compound through the machine to break up any mineral or chemical build-up that may have formed from the use of hard water or chemicals.

The vacuum motor and the pump do not require any scheduled maintenance; however, the vacuum motor may require replacement brushes after 700 - 1000 hours.

To maintain a professional image, clean the body with an all purpose detergent, and protect it with automobile interior polish. Lubricate the wheels, castors, and quick disconnects with an all purpose, silicone spray.

VIEWS OF MACHINE

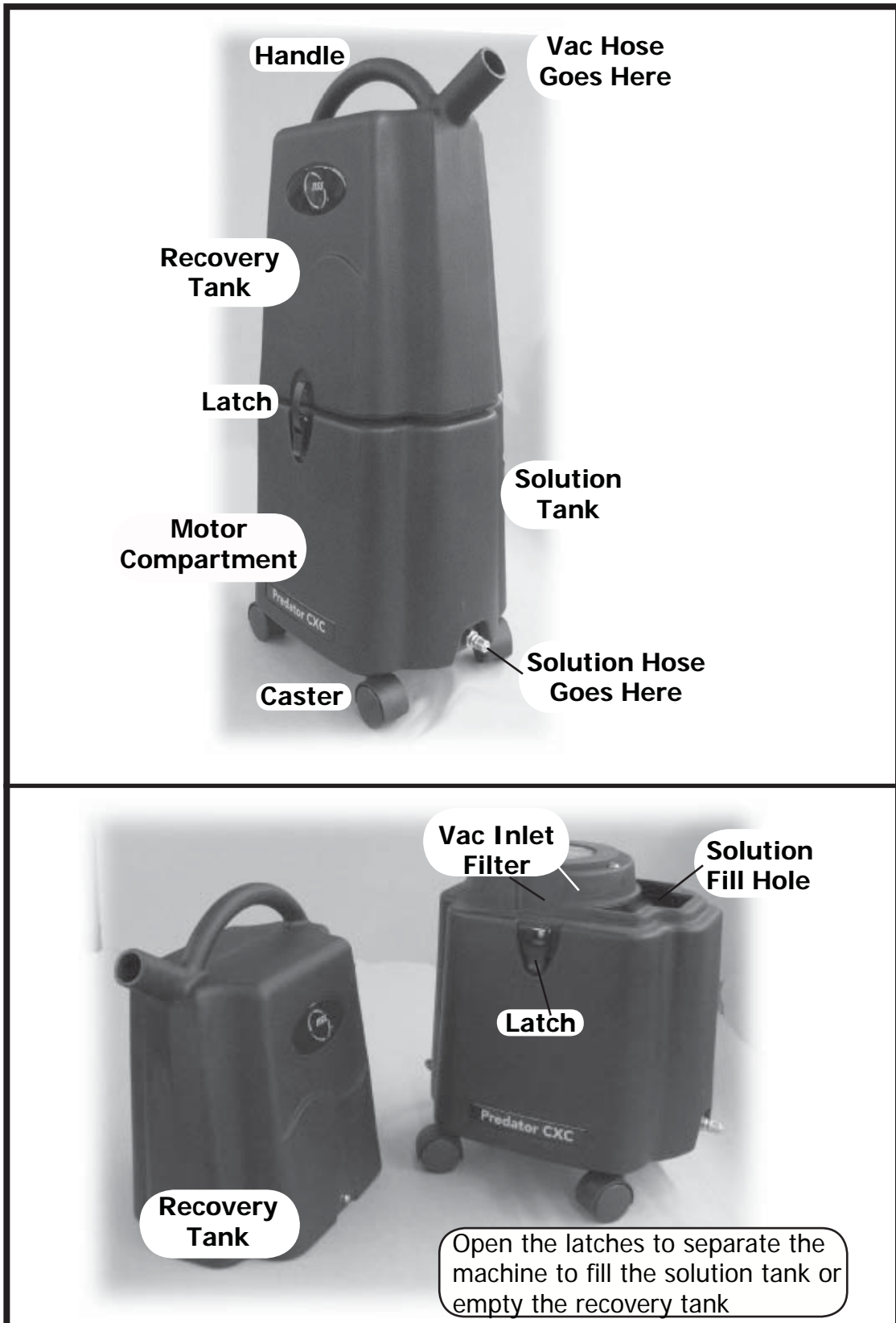

Figure 1

SET-UP AND OPERATING INSTRUCTIONS

1. Inspect the machine, hoses and tool for cleanliness and readiness for use.
2. Release the two latches, grasp the handle on top of the recovery tank, and pull the recovery tank up (Figure 1) and off the solution tank. Set the recovery tank aside.
3. Fill the solution tank with up to 2 gallons of clean, warm water. **NOTE:** do not use water with a temperature exceeding 120° F (49° C) in the solution tank. **CAUTION:** do NOT use solvents. The Predator CXH Spotter has a built-in heater that will supply continuous hot water at the spray tip.
4. Replace the recovery tank back onto the solution tank and secure both latches.
5. Connect the solution hose to the quick coupling on the machine and connect the other end of the solution hose to your cleaning tool. Push the vacuum hose onto the vacuum inlet port on the machine's recovery tank and the other end onto the tool.
6. Plug the power cord into a properly grounded outlet.
7. Turn on the pump (Figure 2, set the switch to the right to turn on both the pump and the vacuum and to the left to turn on only the vacuum. Middle position is off) and spray through your cleaning tool and heater for a few seconds to fill the lines with water, then turn the switch off.
8. CXH only - Turn on the heat switch (Figure 2) to allow the heater two minutes to reach operating temperature.
9. Pre-spray the area to be cleaned with a high quality, non-foaming cleaner mixed to product specifications. **NOTE:** if foaming occurs, use a defoaming agent to prevent damage to electrical components. Water damage is not covered by the warranty.
10. Turn on both the pump and vacuum (Figure 2).
11. Begin cleaning. **NOTE:** the machine has a suction shut-off float in the recovery tank to prevent over-flow. If the suction stops, turn off the machine, remove and empty the recovery tank.
12. When the job is finished, empty the recovery tank and rinse it clean. Remove any remaining liquid from the solution tank.

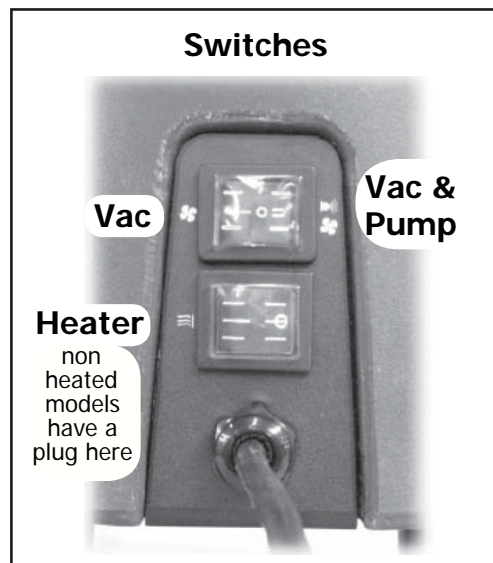
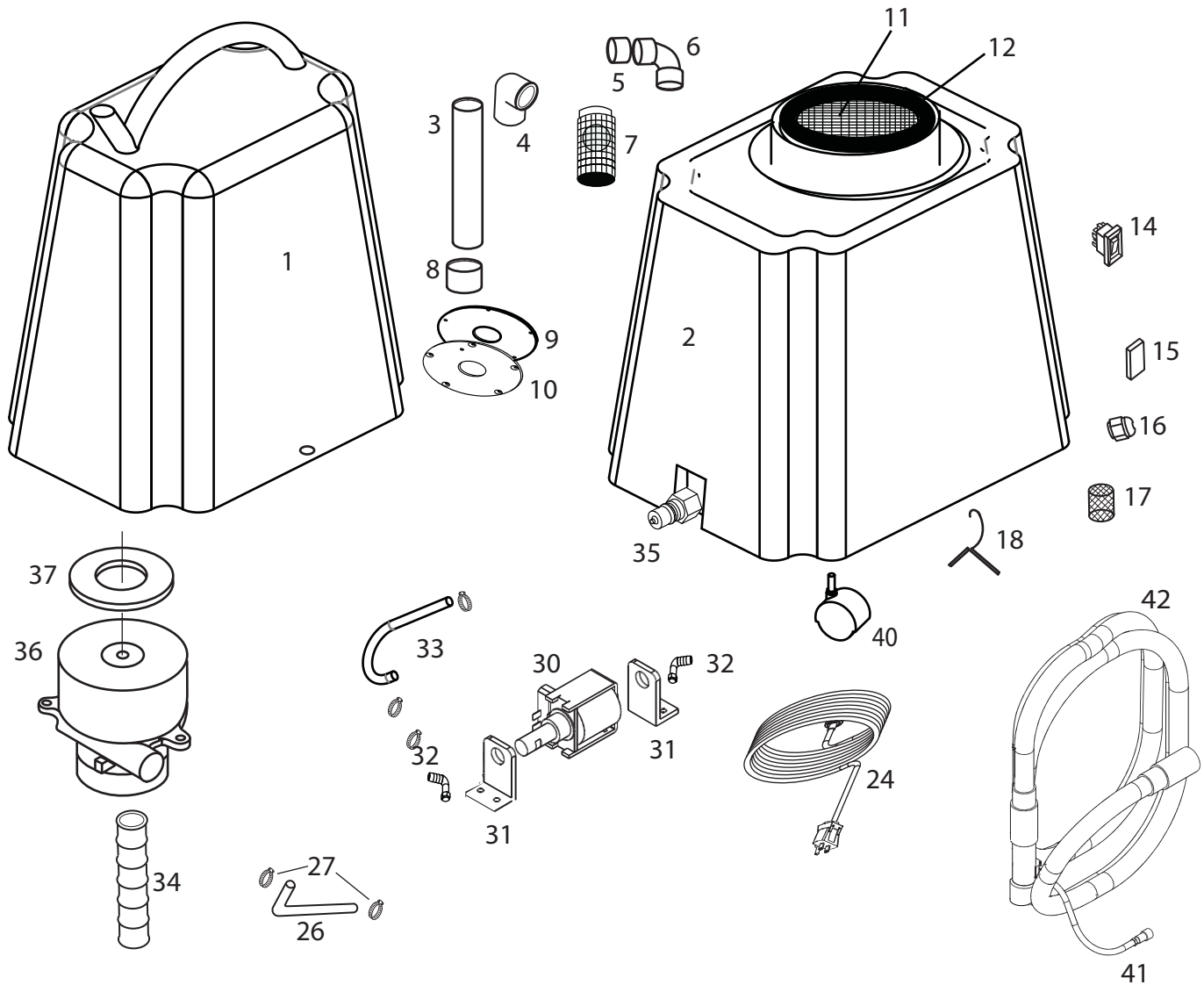

Figure 2

Predator CXC Spotter



Item No.	Part No.	QTY	Description
1	4096651	1	Tank, recovery, Spotter
2	4096661	1	Tank, solution, Spotter
3	4096551	1	Pipe, 1" X 6.5" PVC
4	4092441	1	Elbow, 90 degree, PVC
5	4096581	1	Bushing, 1"x 1.5" PVC
6	4092441	1	Elbow, 1.5"
7	4096461	1	Ball float
8	4096561	1	Coupling, slip fit, PVC
9	4096571	1	Gasket, ball float plate
10	4096511	1	Plate, ball float mounting
11	4096721	1	Screen, vac inlet, 5"
12	4096731	1	Gasket,
13	4096361	2	Hose clamp
14	4092291	1	Switch, rocker, vacuum & pump
15	4092381	1	Plug
16	4096501	1	Cord retainer, for power cord
17	4096741	1	Filter, pump inlet
18	4096441	2	Latch

Item No.	Part No.	QTY	Description
24	4096391	1	Power Cord, 25 ft
25	4096711	1	Hose, black, 8"
26	4096641	1	Hose, Red, measure for length
27	4092391	4	Hose clamp
30	4096411	1	Pump, 55 psi
31	4096471	2	Bracket, pump mounting
32	4096621	2	Hose barb/elbow, nylon
33	4096641	1	Hose, red 14.5"
34	4093411	1	Hose, 2" X 13", wire supported
35	4092491	1	Quick disconnect, male
36	4096801	1	Vac motor, 120V
37	4096521	1	Gasket, vac motor
40	4096451	4	Caster
41	4096351	1	Solution line assembly, 10 ft
42	4096541	1	Vac hose assembly, 10 ft

Predator CXH Spotter

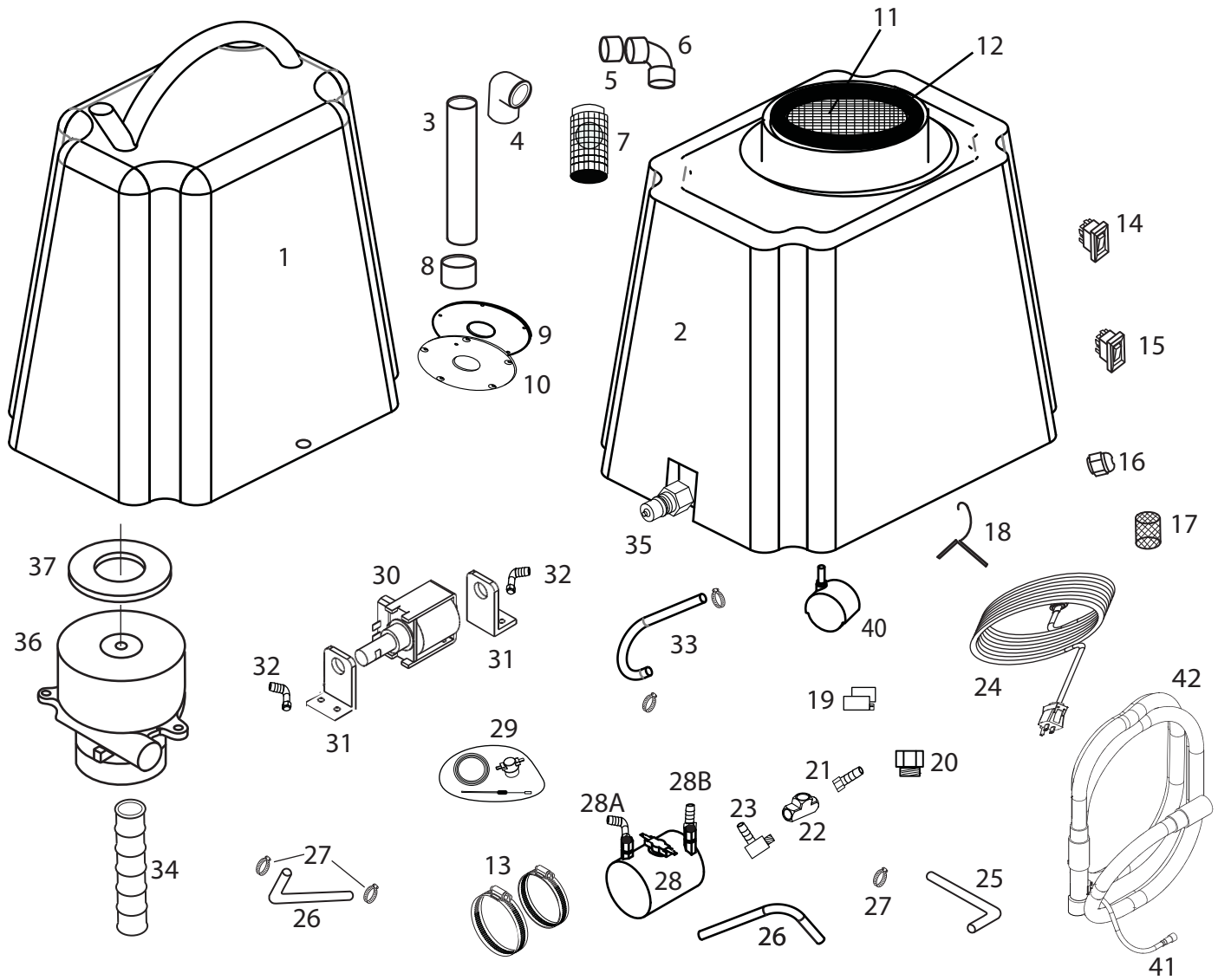

Item No.	Part No.	QTY	Description	Item No.	Part No.	QTY	Description
1	4096651	1	Tank, recovery, Spotter	22	4096811	1	"T", brass
2	4096661	1	Tank, solution, Spotter	23	4096591	1	Elbow, hose barb
3	4096551	1	Pipe, 1" X 6.5" PVC	24	4096391	1	Power Cord, 25 ft
4	4092441	1	Elbow, 90 degree, PVC	25	4096711	1	Hose, black, 8"
5	4096581	1	Bushing, 1"x 1.5" PVC	26	4096701	1	Hose, blue, measure for length
6	4092441	1	Elbow, ABS	27	4092391	6	Hose barb
7	4096461	1	Ball float	28	4096771	1	Heater, complete
8	4096561	1	Coupling, slip fit PVC	28A	4096781	1	Hose barb/elbow, brass
9	4096571	1	Gasket, ball float plate	28B	4096791	1	Hose barb, brass
10	4096511	2	Hose clamp	29	4093391	1	Heat repair kit
11	4096721	2	Hose clamp	30	4096411	1	Pump, 55 psi
12	4096731	1	Gasket,	31	4096471	2	Bracket, pump mounting
13	4096361	2	Hose clamp	32	4096621	2	Hose barb/elbow, nylon
14	4092291	1	Switch, rocker, vacuum & pump	33	4096641	1	Hose, red 14.5"
15	4092281	1	Switch, rocker, heat	34	4093411	1	Hose, 2" X 13", wire supported
16	4096501	1	Cord retainer, for power cord	35	4092491	1	Quick disconnect, male
17	4096741	1	Filter, pump inlet	36	4096801	1	Vac motor, 120V
18	4096441	2	Latch	37	4096521	1	Gasket, vac motor
19	4096751	1	Switch, low pressure detection	40	4096451	4	Caster
20	4096761	1	Bushing, brass	41	4096351	1	Solution line assembly, 10 ft
21	4096631	1	Hose barb, brass	42	4096541	1	Vac hose assembly, 10 ft

TROUBLESHOOTING



ALWAYS UNPLUG THE MACHINE BEFORE DISCONNECTING OR CONNECTING ANY WIRES OR COMPONENTS.

SYMPTOM	POSSIBLE CAUSE
No spray	solution tank is empty; solution hose is not completely connected to machine & tool; spray tip on tool is plugged; pump is not running; pump inlet filter is dirty or plugged;
Pump not running	no power to pump <ul style="list-style-type: none">• check outlet for power;• power to cord or switch is bad;
Low suction	recovery tank not sealed; damaged vacuum gasket; dirty vacuum inlet screen; recovery hose loose or cracked;
No suction	recovery tank is full; vacuum motor not running; <ul style="list-style-type: none">• check outlet for power• power cord is bad• bad switch• bad vac motor

Always use original equipment replacement parts.

Contact your distributor for additional information or to arrange for service.

Predator CXC and CXH Spotter

NOTES:



NSS Enterprises, Inc.
Corporate Headquarters
3115 Frenchmens Rd.
Toledo, OH 43607
419-531-2121
www.nss.com