



Midsized Extractor

OPERATORS MANUAL AND PARTS LIST

Model PFX1080 SERIES



WARNING: OPERATOR MUST READ AND UNDERSTAND THIS MANUAL COMPLETELY BEFORE OPERATING THIS EQUIPMENT.

IMPORTANT SAFETY PRECAUTIONS

WARNING! To reduce the risk of fire, electric shock, or injury

WARNING
To avoid fire, DO NOT use with a flammable or combustible liquid to clean floor.



WARNING
To avoid electric shock, DO NOT expose to rain. Store Indoors.

When using this upright extractor, basic precautions should always be followed, including the following:

- 1) **DO NOT** leave unit when plugged in. Unplug from outlet when not in use and before servicing.
- 2) **DO NOT** allow unit to be used as a toy. Close attention is necessary when used around or near children.
- 3) Use only as described in this manual. Use only manufacturer's recommended attachments.
- 4) **DO NOT** use with damaged cord or plug. If unit is not working properly because it has been dropped, dropped into water, left outdoors, or damaged in any way, contact an authorized service center.
- 5) **DO NOT** handle plug or appliance with wet hands.
- 6) **DO NOT** put any objects into openings. **DO NOT** use with any opening blocked: keep free of dust, lint, hair, or anything that may reduce air flow.
- 7) Keep hair, loose clothing, fingers, and all parts of body away from openings and moving parts.
- 8) **DO NOT** pick up anything that is smoking or burning such as cigarettes, matches, or hot ashes.
- 9) **DO NOT** use to pick up hazardous chemicals.
- 10) Turn off all controls before unplugging.
- 11) Turn unit off immediately if foam or liquid comes from machine exhaust. Empty & clean out recovery (dirty) tank and use defoamer to correct the problem.
- 12) **DO NOT** use to pick up flammable or combustible liquids such as gasoline or use in areas where they may be present.
- 13) **DO NOT** use where oxygen or anesthetics are used.
- 14) Replace damaged or worn parts immediately with genuine original equipment parts to maintain safety.
- 15) This unit must be connected to a properly grounded outlet only. See grounding instruction on page 3.

GROUNDING INSTRUCTIONS

DANGER: Improper use of the grounding plug can result in a risk of electric shock.

GROUNDING INSTRUCTIONS

This extractor must be properly grounded. If it should malfunction or breakdown, grounding provides a path of least resistance for electrical current to reduce the risk of electric shock. This machine is equipped with 1 or 2 pigtail cords having an equipment-grounding conductor and grounding plug. The pigtails must be inserted into an appropriate 12 gauge 3 prong extension cord. This unit is for use on a nominal 120 volt circuit and has a grounded plug that looks like the plug illustrated in (Fig. A).

GROUNDING METHODS

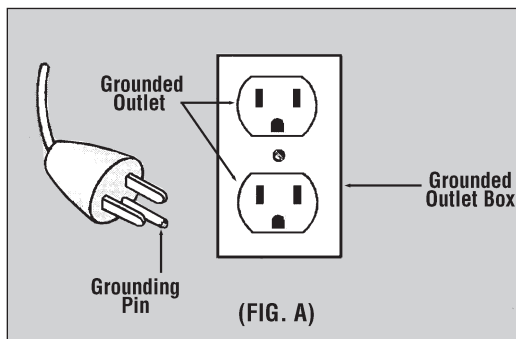

This unit is for use on a nominal 120 volt circuit and has a grounded plug that looks like the plug illustrated in (Fig. A).

WARNING!

Improper connection of the equipment-grounding conductor can result in a risk of electric shock. Check with a qualified electrician or service person if you are in doubt as to whether the outlet is properly grounded. **DO NOT** modify the plug provided with the appliance. If it will not fit the outlet, have a proper outlet installed by a qualified electrician.

General instructions for PFX1080 series Extractors

Congratulations on your purchase of a Powr-Flite extractor. You are now equipped to handle any and all commercial carpet cleaning jobs.

Shipping and Damage

This equipment is thoroughly inspected, tested, and packaged to provide equipment in good operating condition. It is beyond our control after the equipment is turned over to a freight carrier. The freight carrier received and signed for the equipment in good condition. Consequently, it is most important to protect your interest by carefully complying with the following instructions:

Please inspect your cartons for any damage (including concealed damage) that might have occurred during shipment. Any damage is the responsibility of the freight carrier and should be reported to the freight carrier immediately. It is your responsibility to issue a claim and to receive compensation from the freight carrier for any damage done in transit. Damage of this sort is not warranted.

Follow these easy step-by-step instructions to ensure proper operating performance.

1. Fill up the fresh water solution tank with tap water that is 120-135 degrees and approved carpet cleaning chemical, if you are not pre-spraying your chemical on the carpet.
2. Attach two 12 gauge extension cords (NOT INCLUDED) (one cord for non-heated models) to each of the pigtail cords located on the lower backside of the unit. The red pigtail powers the heater while the black pigtail powers the vacuum motors and pump.
3. Plug each extension cord into a separate and grounded 20 amp wall socket circuits. When this is accomplished the green indicator light will be lit (on heated models).
4. Attach the hose system to the unit and to your carpet wand.
5. Turn on the heater and the pump to the "on" position, (only pump on non-heated models). When the heater is on, the orange indicator light on the switch panel will be lit.
6. With the solution line attached to the wand and the achine, prime the pump by squeezing the trigger on the wand releasing the water (hold wand tip over solution tank to put water back into solution tank). This will pump water into the heater and get any air out of the solution line. Let the heater heat up this will take 3 to 5 minutes. *Prime pump on 400 p.s.i. models with prime hose (included).
7. Turn vacuum switches to the "on" position one at at time to begin cleaning.
8. Anyone designated to operate this equipment must read and thoroughly understand all instructions and precautions prior to use.
9. Never use equipment out of doors or in the rain.
10. Never use flammable or explosive materials in or around this equipment!
11. When vacuum tank is full, empty by using dumping valve on the front of the machine. If a pail is used to empty the vacuum waste tank, do not use the same pail to fill the solution tank as this can result in putting dirt and grit into the solution line that can plug filters, orifices, and generally degrade the solution line system (do not reuse solution).
12. To empty solution tank, detach the wand from the end of the vacuum hose and insert the vacuum hose into the solution tank. Turn the vacuum switches to "on" position and transfer solution to vacuum tank and dispose of as outlined in #11. Clean vacuum stack filter at this time.

Maintenance

To receive reliable service from this equipment, regular daily maintenance is a required.

1. Keep the equipment clean, both inside and out.
2. Lubricate brass quick disconnects and drain valves with a quality lubricant such as WD-40®.
3. Flush solution systems after use with clear, clean water. (A white vinegar solution may also be used). This will counter-act hard water and alkaline deposits and aid in keeping orifices clean.
4. Do not allow fluid, either in solution or waste tank, to sit overnight. The unit should be emptied and cleaned daily.
5. Clean the strainer in the solution tank, the filters on the vacuum stack in vacuum tank, and all lint filters in the inlet or vacuum tanks daily.
6. Do not use the same receptacle (pail) to fill solution tank that is used to remove waste from vacuum tank.
7. When the unit is not in use, leave the vacuum tank lid open.
8. At the end of each day, run the vacuum for 3 minutes with lid open and filter off.

Safety Precautions

These precautions are designed with the safety of the operator, the equipment, and others in mind and must be followed at all times to avoid serious personal harm and/or death, and damage to the unit.

1. Always use a grounded electrical outlet.
2. Always disconnect electric cable from electrical outlet before attempting to make any adjustments or repairs.

3. Never use this equipment as a toy.
4. Never use equipment near or around flammable or explosive materials, fuels, or solvents.
5. Never put flammable materials, fuels, or solvents into equipment.
6. Never lift the machine by dumping valve.
7. Do not allow the unit to freeze!
8. The equipment was not designed to be used outdoors or in the rain.
9. Do not operate in standing water.
10. Wear safety equipment and clothing to protect from extremely hot water.
11. Do not operate equipment under any unsafe condition.
12. Do not operate if pigtailed, hoses, etc. are cracked, frayed, leaking, or otherwise in need of repair.



Storage of Equipment

1. Store extractor indoors in dry area.
2. Recovery and solution tank should be empty and clean when the extractor is not in use.
3. Leave the recovery lid and dump valve open to air out the recovery tank.
4. Do not store in freezing temperature.
5. A small amount of windshield washer fluid may be left in the pump and internal solution line for protection against freezing.

Warnings

1. Do not break off or pull the grounding prong on the plug.
2. Do not attempt repair on a warranted machine unless instructions to perform it by an authorized shop are obtained from the factory.
3. Do not use citrus-based (D-Limonene) cleaners in this machine.
4. Do not use cleaning chemicals in this machine except those recommended for steam-type extraction equipment. The use of any chemicals with abrasive additives voids the warranty.

5. Do not use any replacement parts except those specified on the parts list. Performance of the machine could be affected if substitutions are made.
6. Do not use water in excess of 140° F (62° C) through the pump system. It could damage the seals and polypropylene casing of the diaphragm pump.
7. Follow maintenance schedule strictly.
8. **Failure to comply with the above warnings instructions will void the warranty.**



ONE LAST REMINDER

Read All Instructions, Warning and Cautions Before Using. These guidelines are presented for your protection and convenience. Please read them carefully, since failure to heed these precautions could result in discomfort or injury. When using an electrical appliance, basic safety precautions should always be followed.

WARNING

TO AVOID FIRE, DO NOT USE WITH A FLAMMABLE OR COMBUSTIBLE LIQUID TO CLEAN FLOOR.

MODEL PFX1080 SERIES CARPET EXTRACTOR PARTS

PFX1080 base assembly

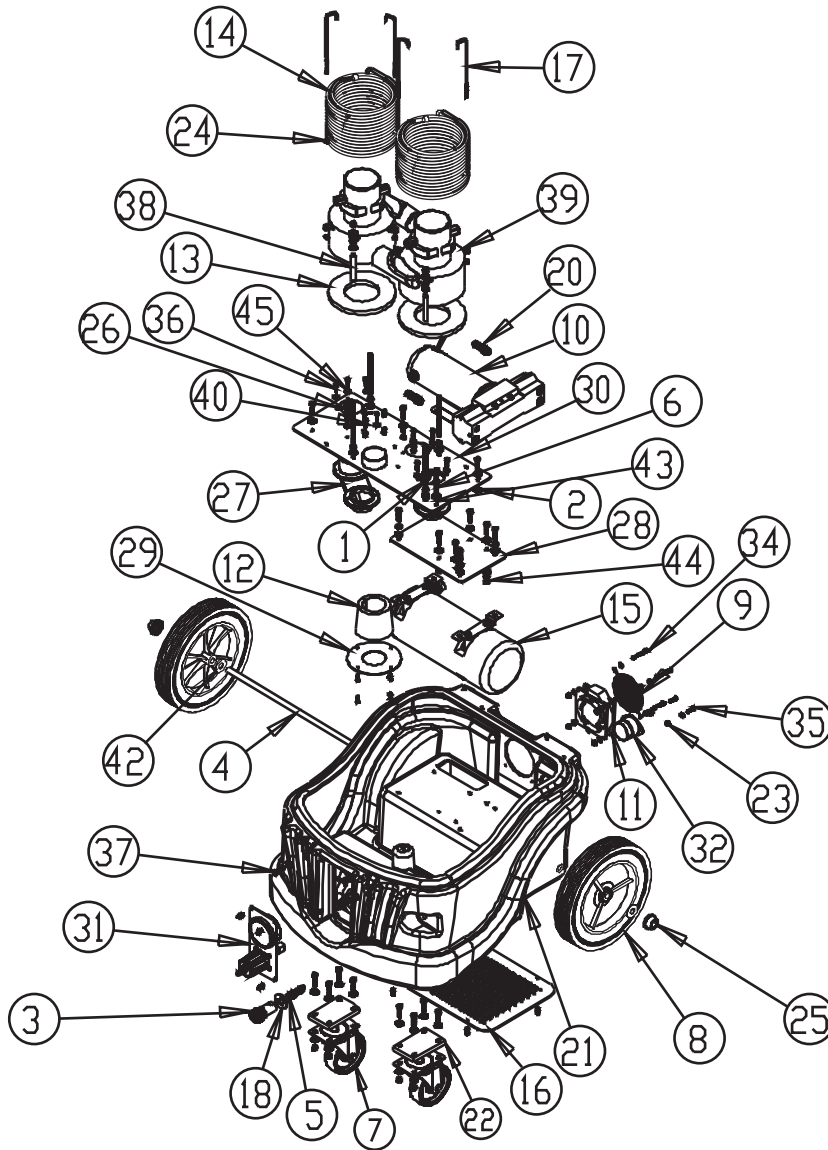

ref#	description	order #	ref#	description	order #
1	10-24 ALL THREAD	72000A	24	NUT 10-32 KEPS	7BF008
2	WASHER 5/16 SAE FLAT ZINC	X8235+	25	NUT PUSH 1/2"	7GL002
3	1/4" QUICK DISCONNECT PX6+		26	NUT, KEP 10-24 ZINC	7BF003
4	AXLE REAR MID SIZE	X9463+	27	PLASTIC VACUUM CHAMBER	X9467+
5	BARB, 1/2 HOSE 1/4 MALE	7AT004	28	PLATE, HEATER /PUMP, MID SIZE EXTRACTOR	X9465+
6	BOLT 1/4-20 X 1"	X8211+	29	PLATE MUFFLER MID SIZE EXTRACTOR	X9471+
7	CASTER, 4" BLACK	71474A	30	PLATE VACUUM MID SIZE EXTRACTOR	X9466+
8	WHEEL 10" GREY	X9063+	31	PRESSURE GAUGE ASSEMBLY PLATE, 100 PSI	X9501+ X9494+
9	COVER FAN	72702A	32	RECEPTACLE, FLANGED INLET STRAIGHT BLADE	X9429+
10	PUMP 200 PSI 115V; PUMP 100 PSI 115V PUMP 500 PSI 115V	PT400+ X9179+ PT400MS	33	SCREW SHEET METAL #8X5/8" BLACK	72387A
11	FAN COOLING 115V	72700A	34	SCREW, 8-32 X 1 3/4" MACHINE PH ZINC	C9476+
12	FDAM, MUFFLER, MID SIZE EXTRACTOR	X9470+	35	SCREW, 8-32 X 3/4", MACHINE PH ZINC	C8298+
13	GASKET, VACUUM MOTOR SEAL	70020B	36	SCREW, 10-24 X 3/4 MACHINE PH BLACK	C8276+
14	HEAT COIL	72713A	37	SCREW, 1/4-20 X 1 PHIL PAN	7BS003
15	HEATER DUAL ELEMENT	X9105+	38	SPACER VAC MOTOR	72651A
16	HEATER COVER, MID SIZE EXTRACTOR	X9464+	39	VACUUM 2-STAGE VACUUM 3-STAGE	1942-IE+ 72365A
17	J-HOOK 6.25" 2-STAGE	X9424+	40	VACUUM CHAMBER GASKET	X9468+
18	WASHER, 1/2 USS FLAT ZINC	X8239+	41	WASHER #8 FLAT, BLACK	X9362+
19	NUT KEP 1/4-20"	7BF004	42	WASHER 1/2 USS FLAT 18-8 SS	7CM007
20	BARB, 1/2H 3/8M	PX218+	43	WASHER 1/4 MED SPLIT LOCK ZINC	X8212+
21	MEDIUM SIZE EXTRACTOR BASE	X9441+	44	WASHER 1/4 MED SPLIT LOCK ZINC	X8213+
22	SPACER, CASTER	72783A	45	WASHER, #10 FLAT ZINC	X8225+
23	NUT 8-32 KEPS	X8256+			

MODEL PFX1080 SERIES CARPET EXTRACTOR PARTS

PFX1080 recovery tank assembly

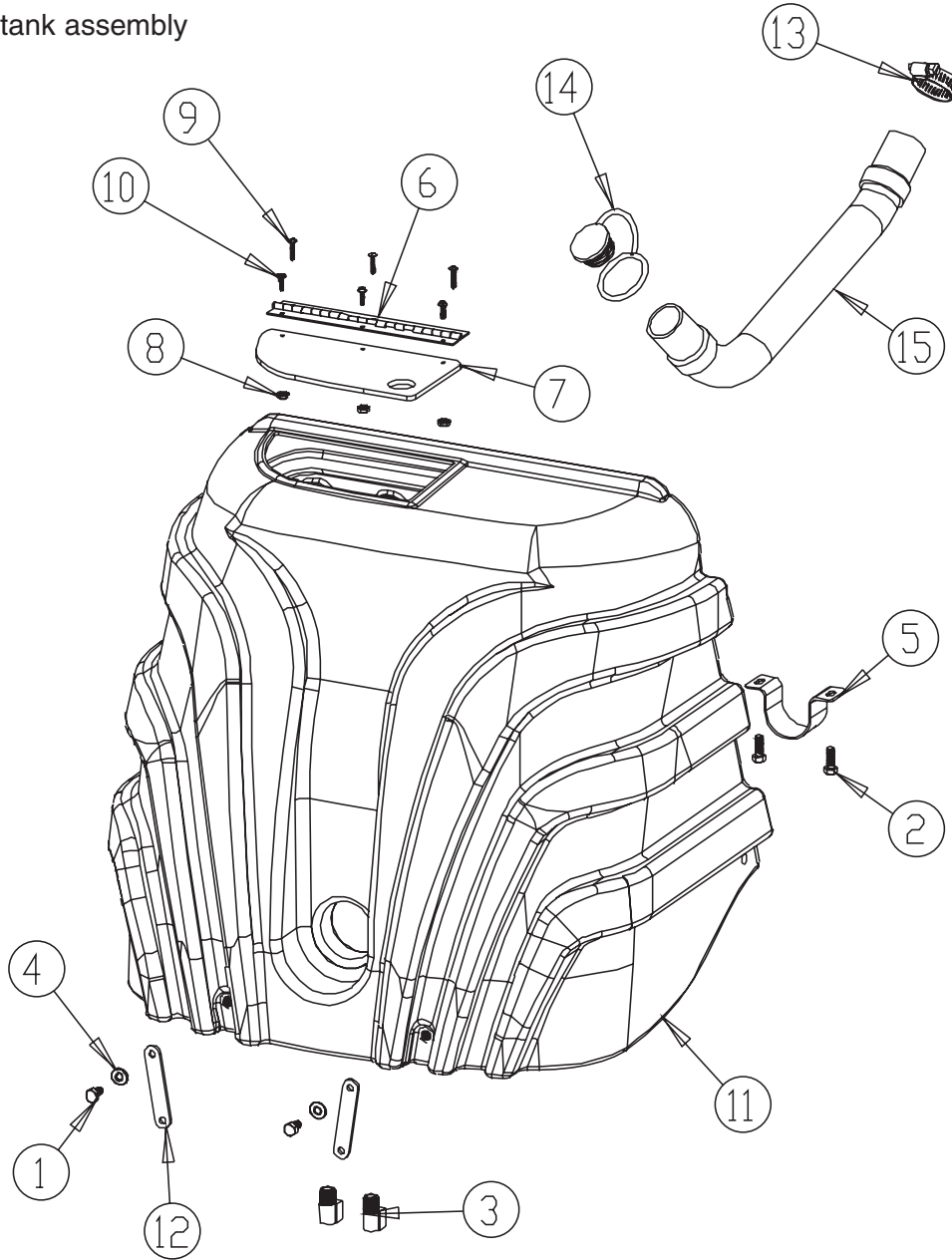

ref#	description	order #	qty
1	1/4-20 X 1/2 HEX CAP SCREW	X8209+	2
2	1/4-20 X 3/4 HEX CAP SCREW	X8268+	2
3	1/4" 90 DEGREE STREET ELBOW	PC49+	2
4	1/4" FLAT WASHER	X8235+	4
5	CLAMP, DISCHARGE VALVE	X9448+	1
6	HINGE SOLUTION TANK LID	X9450+	1
7	LID, SOLUTION TANK	X9451+	1
8	NUT 8-32 KEPS ZINC	X8256+	3
9	SCREW SHEET METAL #8X3/4" BLACK	X9349+	3
10	SCREW, 8-32 X 1/2" MACHINE PH BLACK	X8278+	3
11	SOLUTION TANK AS MOLDED	X9442+	1
12	STRAP, FRONT, MID SIZE EXTRACTOR	X9444+	2
13	CLAMP, 1 1/2" WORM GEAR	7DL005	1
14	PLUG DRAIN HOSE	PS36+	1
15	DRAIN HOSE	PS37+	1

MODEL PFX1080 SERIES CARPET EXTRACTOR PARTS

PFX1080 solution tank assembly

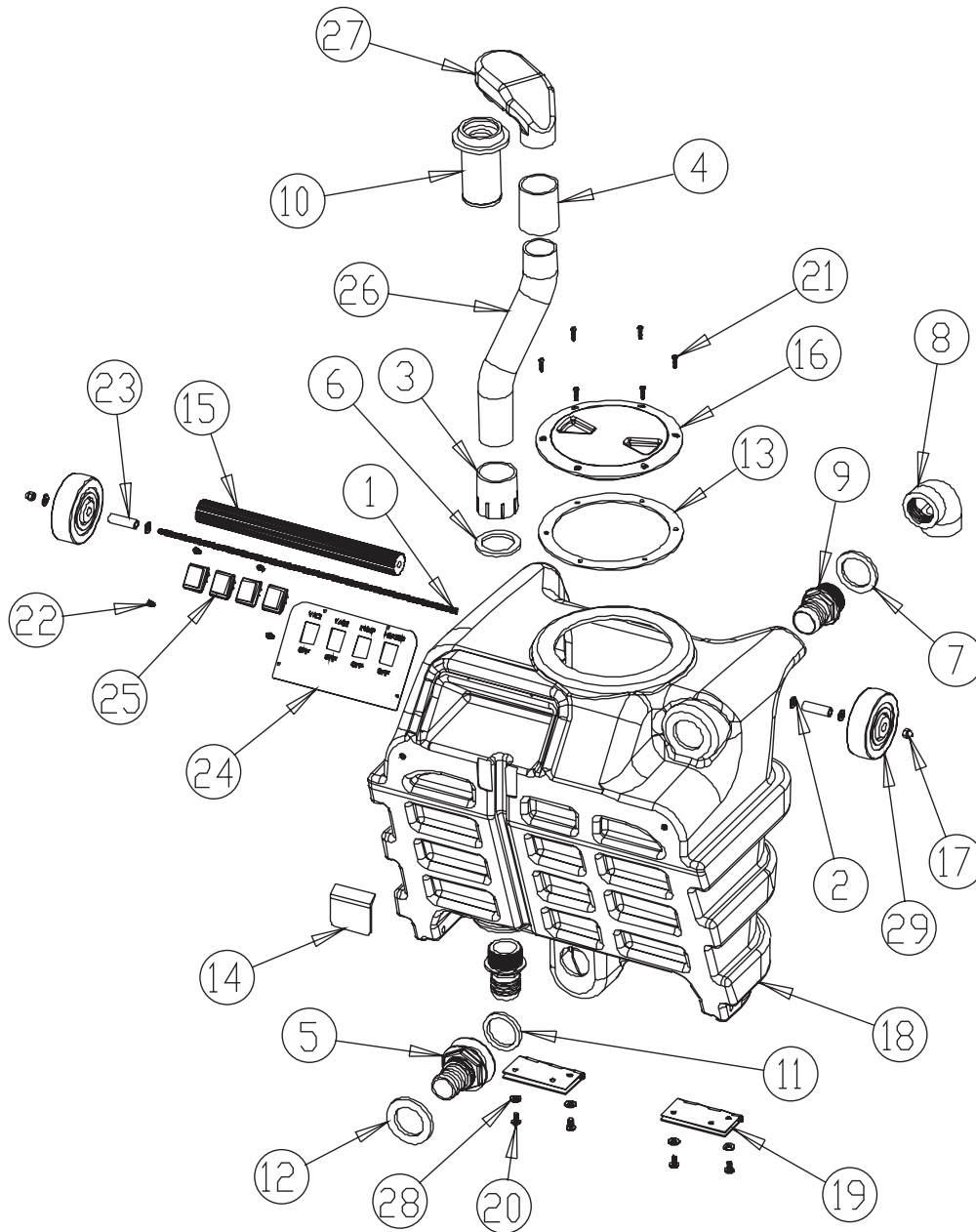

ref#	description	order #	qty	ref#	description	order #	qty
1	1/4-20 X 18.75 ALL THREAD ZINC	X9452+	1	15	HANDLE, MID SIZE EXTRACTOR	X9453+	1
2	1/4" FLAT WASHER	X8235+	4	16	LID, SCREW IN 6" CLEAR W/ BLACK RING	PX103+	1
3	COUPLER PLASTIC 1 1/2 SLIP/THREAD	PX63+	1	17	NUT CAP 1/4-20 ACORN SS	7DN002	2
4	COUPLING PVC 1 1/2"	72615A	1	18	RECOVERY TANK AS MOLDED	X9443+	1
5	DRAIN FITTING 1" HOSE BARB	72677A	1	19	SCE TANK HINGE	X9014+	2
6	DUMP VALVE GASKET 1 1/2 2.5 OD 1/75 RUBBER	PX14+	1	20	SCREW 1/4-20 X 1/2 PHIL PAN	7BS003	4
7	DUMP VALVE GASKET 1 1/2 2.5 OD 1/75 RUBBER THIN	PX14A+	1	21	SCREW SHEET METAL #8 X 3/4" BLACK	X9349+	6
8	FITTING 1 1/2" 90 DEGREE ELL, PLASTIC	PX11A+	1	22	SCREW SHEET METAL #8 X 5/8" BLACK	72387A	4
9	FITTING PLASTIC 1 1/2"NPT 1 1/2" HOSE BARB	PX25+	2	23	SPACER, 1.625 LONG .5OD, .313 ID	72486A	2
10	FLOAT CAGE W/ HEAV BALL	PX31+	1	24	SWITCH PANEL, MID SIZE EXTRACTOR	X9455+	1
11	GASKET DRAIN INNER 1.8 ID 2.3 OD	X9461+	1	25	SWITCH ROCKER, DPST 20A	PX87+	4
12	GASKET DRAIN OUTER 1.8 ID 2.8 OD	X9462+	1	26	VACUUM STANDPIPE, MID SIZE EXTRACTOR	X9456+	1
13	GASKET LID.8" ODX6 5/8" ID 1/8" THICK	PX103G+	1	27	VACUUM TUBE	PX33+	1
14	GASKET SWITCH WIRES MID SIZE EXTRACTOR	X9454+	1	28	WASHER ID.299 OD.622 THK.055	X8858+	4
				29	WHEEL, BLACK 4" X 1 1/4"	X8025+	2

Troubleshooting Information

ELECTRICAL SYSTEM

PROBLEM	POSSIBLE CAUSE	SOLUTION
No electrical power.	<ol style="list-style-type: none"> 1. Defective power cord. 2. Circuit breaker off or fuse blown. 	<ol style="list-style-type: none"> 1. Replace. 2. Turn circuit breaker on or replace fuse. Unplug any equipment using the same circuit.
Switch is turned on.	1. Faulty electrical cable.	1. Repair or replace.
Intermittent power to motor(s).	2. Defective switches.	2. Replace.
	3. Loose terminal or discolored terminal connections.	3. Replace.
Electrical Shock	1. Equipment not grounded.	1. Locate grounded outlet.

VACUUM SYSTEM

PROBLEM	POSSIBLE CAUSE	SOLUTION
Vacuum motor on. Little or no vacuum on wand head.	1. Drain hose open.	1. Close drain hose. Recovery tank lid must be closed.
	2. Defective vacuum hose. Kinks in vacuum hose.	2. Repair or replace hose.
	3. Vacuum disconnected.	3. Open machine, connect vacuum hose to recovery tank.
Not enough vacuum power at the machine.	1. Damaged recovery tank lid.	1. Replace.
	2. Lint clogging ball - type shutoff screen.	2. Remove screen. Clean out fibers and accumulated dirt.
	3. Vacuum hose connection between stand pipe and vacuum motor.	3. Check for leaks around clamps and cuffs (tighten). Replace damaged hose(s).
	4. Vacuum motor exhaust blocked.	4. Check air flow by removing hose from machine and feel the exhaust under the machine. Remove obstruction.
	5. Cords not plugged into separate circuits	5. Relocate one cord to a different room.

VACUUM SYSTEM

PROBLEM	POSSIBLE CAUSE	SOLUTION
Motor running and no vacuum at all.	1. Faulty vacuum motor.	1. Replace.
No exhaust from the blowport.	2. Water shutoff closed.	2. Clean water shutoff screen.
Premature closing of ball type shutoff.	1. Dirty or clogged shutoff filter screen.	1. Remove and clean screen.
Ball type shutoff failing to release after recovery tank is drained.	2. Ball coated with detergent or other foreign material.	2. Remove and rinse ball with clean water.
	2. Screen slightly out of round.	3. Bend screen by squeezing slightly by hand until there is an obvious space between ball and inside of screen.

Foam/dirty solution coming out of vacuum exhaust port.	<ol style="list-style-type: none"> 1. Foam from carpet bypassing water shutoff. 2. Elbow in vacuum tank is not positioned correctly. 	<ol style="list-style-type: none"> 1. Use additional defoamer. 2. The elbow should be pointed directly at the side wall of the tank away from the ball type shutoff.
--	--	--

SOLUTION SYSTEM

PROBLEM	POSSIBLE CAUSE	SOLUTION
Pump motor on – no spray through jets.	1. Clogged or faulty solution control valve.	1. Check intake on valve and remove lint or other foreign material.
	2. Clogged or faulty quick disconnect on housing.	2. Depress plunger on solution hose against inside wall of solution tank. If solution is flowing at this point, the system is O.K. If no solution flows, check the quick disconnect for lint and other foreign matter.
	3. Punctured pump diaphragm.	3. Replace with diaphragm repair kit.
	4. Clogged jets	4. Clean jets on wand or tool.

PROBLEM	POSSIBLE CAUSE	SOLUTION
Uneven spray from jet. Spray weak or uneven.	1. Clogged strainer in solution tank.	1. Unscrew strainer and remove lint and any other foreign material from screen.
	2. Clogged jet.	2. Remove and clean.
Leaking or stuck solution valve.	1. Foreign material in valve.	1. Remove brass hex plug, clean valve and replace.
	2. Loose brass hex nut.	2. Reseal hex and plug.
	3. Valve worn or seals worn.	3. Replace worn parts with solution valve repair kit.
Pump motor not working.	<ol style="list-style-type: none"> 1. Loose wiring 2. Defective pump pressure switch 3. Motor burnout 	<ol style="list-style-type: none"> 1. Tighten wiring 2. Replace with new pressure switch assembly 3. Replace pump motor
Pump pressure low.	1. Clogged screens on.	1. Unscrew strainer in solution tank remove lint and any other foreign material from screen.
	2. Punctured pump diaphragm.	2. Replace with diaphragm repair kit.
	3. Defective rectifier or motor.	3. Replace.
	4. Pump not primed.	4. Plug priming hose into solution connection and place end in solution tank. Run pump for 4 minutes
Pump pressure varies.	1. Worn carbon brushes.	1. Replace brushes.
	2. Defective pump pressure control switch.	2. Replace.

WARRANTY

The manufacturer warrants to the original purchaser that products manufactured are free from defects of workmanship and material, provided such goods are installed, operated and maintained in accordance with written manuals or other instructions for a period of 5 years from date of purchase on housings and frame, 3 years on heater, 1 year on pump, vac motor, and parts and workmanship. In case you as our customer, meet any trouble with your machine, contact your Powr-Flite representative who will be happy to be of service to you and will take care of the warranty settlement.

NOTE: Alterations and changes made to the machine without written approval of the manufacturer and use of unapproved spare parts will not be covered by warranty.

Powr-Flite
COMMERCIAL FLOOR CARE EQUIPMENT

A Tacony Company

3101 Wichita Court • Ft. Worth, TX 76140-1710 • (800) 880-2913