

Accessories

Model :99130 24" EZ Floorkeeper - Series L

	Number	Description	Qty Req.
1	99262	PAD HOLDER-20(EZ)	1
2	99260	BRUSH-POLY.SCRUB 20(EZ)	1
3	99263	BRUSH-GRIT 20(EZ)	1
4	99272	PAD HOLDER-24(EZ)	1
5	99270	BRUSH-POLY.SCRUB 24(EZ)	1
6	90676	ATTACHMENT SET-(1-1/2) T-LITE,WET,FLOORKEEPER	1
6	90288	HOSE 1-1/2 X 10' POLYETHYLENE(W/O SLEEVE)	1
6	90286	WAND-DBL.CURVED ALUM 1-1/2 X 4'	1
6	90640	TOOL-FLOOR(1-1/2)T-LITE SQUEEGEE(14)	1
6	90062	HOSE CONNECTOR(1-1/2) NIPPLE(6)	1
7	99510	BATTERY CHARGER-24V/20A W/ RED CON (SB-50)	1
8	99526	BATTERY CHARGER-24V/20A (WORLD)	1

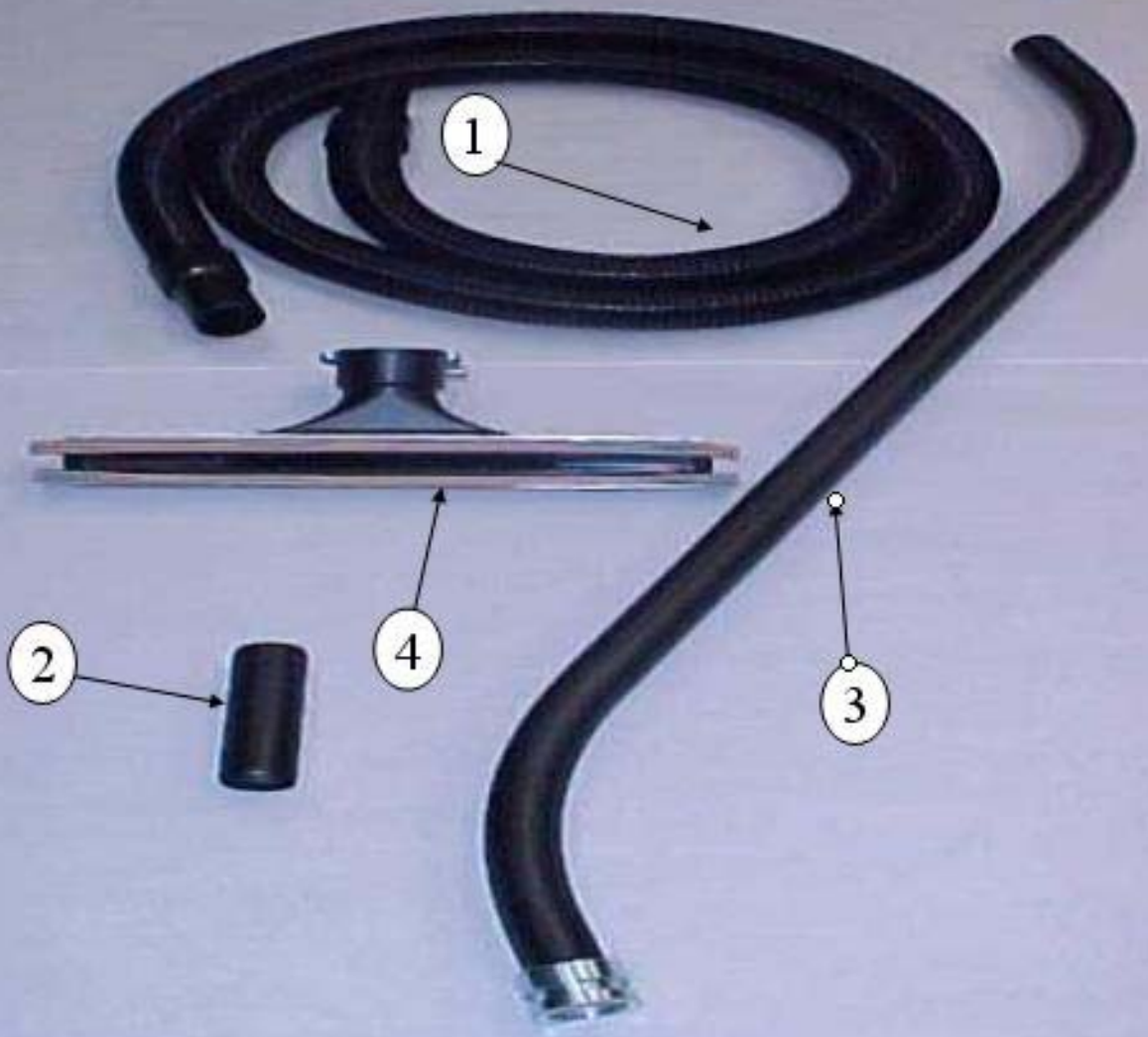

Wiring Diagram, Model:99130 24" EZ Floorkeeper - Series L

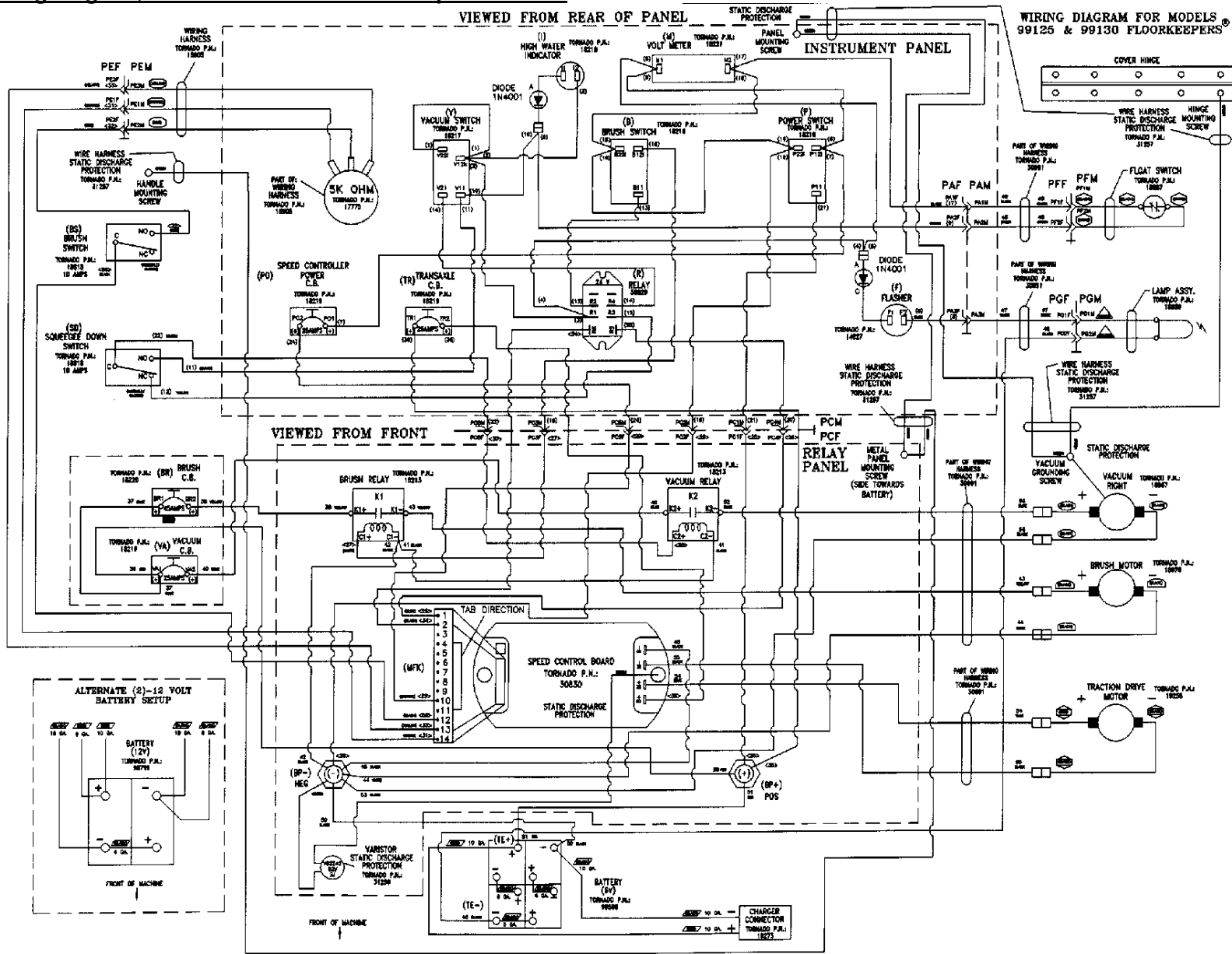

Brush Lift Assembly

Model :99130 24" EZ Floorkeeper - Series L

	Number	Description	Qty Req.
1	02663	USE #03470RING-RETAINING	4
2	18122	PIN	2
3	16581	WASHER-PLAIN .563 ID (SS)	4
4	18196	(MS) WELDMT-BRSH.LFT PDL	1
5	18203	USE #19006PEDAL MAT	1
6	18083	PIN-CLEVIS 3/8 DIA	1
7	18081	CLEVIS 3/8	2
8	18093	NUT-FINISHED HEX 3/8-24 (ZP)	2
9	18191	ROD-LIFT(ZINC PL.SHAFT) (99105-125,126,130)	1
10	18399	SCREW-HEX HD CAP 5/16-18 X 4.00 (ZP)	1
11	02568	WASHER-PLAIN 5/16 ID (ZP)	1
12	18758	WELDMENT-BRUSH RELEASE LATCH	1
13	18126	SPRING-EXTENSION	1
14	18179	BEARING-SPACER	2
15	03955	BUSHING FLANGED NYLON 3/4	2
16	03321	WASHER-PLAIN .391 ID (ZP)	2
17	16671	SCREW-HEX HD CAP 3/8-16 X 5/8 (ZP)	2
18	12554	WASHER-PLAIN 1/2 ID (NATURAL NYL.)	2
19	18185	ARM(20 L.H.) 030	1
	18186	ARM(24 L.H.) 043	1
20	18107	SPACER-3/8	1
21	03736	WASHER-PLAIN 3/8 ID (ZP)	13
	03736	WASHER-PLAIN 3/8 ID (ZP)	10
22	18165	PIN	1
23	03947	RING-RETAINING EXT. 3/8	8
	03947	RING-RETAINING EXT. 3/8	6
24	15677	SCREW-SOCKET HD SHOULDER 3/8D X 3/8 (ZP)	3
25	18872	SCREW-HEX FLANGE HEAD 5/16-18 X 1/2 (ZP)	4
27	07132	WASHER-SPRING 3/8 (3-WAVE)	2
28	01589	NUT-FINISHED HEX W/ LOCTITE 5/16-18 (ZP)	3
29	18164	PLATE-ADJUSTMENT	2
30	18163	PIN	2
31	16347	BEARING FLANGED BRONZE 3/8	4
32	18195	SLEEVE BEARING BRONZE 3/8	2
33	18166	ARM(20 R.H.) 030	1
	18167	ARM(24 R.H.) 043	1
34	18184	WELDMENT-BRUSH LIFT 20 035	1
	18193	WELDMENT-BRUSH LIFT 24 035	1
35	18403	LINK	1
36	18405	PIN-3/8 DIA EXPRESS LINK	1
	18083	PIN-CLEVIS 3/8 DIA	1
	03395	PIN-COTTER 3/32 DIA X 3/4 E/P	1
37	18398	SPRING-EXTENSION	1
38	18397	WELDMENT-TAKE UP ADJUST. BRACKET	1
39	03395	PIN-COTTER 3/32 DIA X 3/4 E/P	1
40	19078	PIN-SPRING 1/2 DIA X 1-1/4 SLL	1

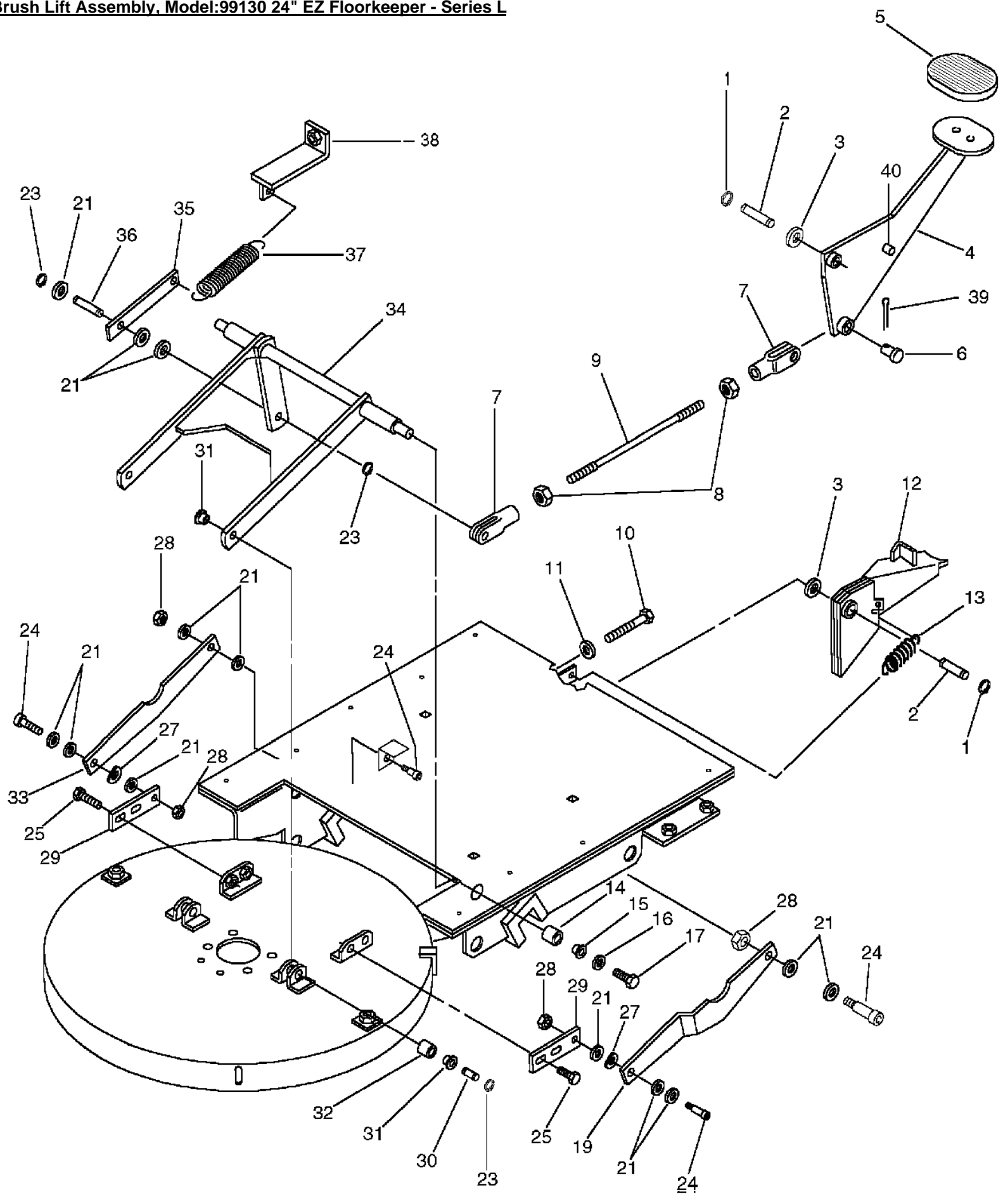

Brush Motor & Cover Assembly

Model :99130 24" EZ Floorkeeper - Series L

	Number	Description	Qty Req.
3	18076	MOTOR-BRUSH(1HP) 24VDC/200RPM	1
4	18148	WELDMENT-BRUSH COVER 20 (99105,-125,-126) PAINT	1
	18149	WELDMENT-BRUSH COVER 24 037	1
5	18388	PLATE - CLUTCH BACKING MUST ORDER W/18389	1
6	14241	SCREW-SET SOCK. 1/4-20 X 1/4(BLK.OXIDE)	1
7	18389	PLATE - BRUSH RETAINER MUST ORDER W/18388	1
8	18390	PIN-GROOVED 5/16 DIA X 1 TP B	2
9	18640	PLATE-BRUSH CLUTCH RETAI NING	1
10	18391	SCREW-SOCK.HEAD CAP(NYLK 5/16-18 X 7/8	1
11	16472	SPRING-EXTENSION	1
12	18159	BUMPER STRAP-20	1
	18160	BUMPER STRAP-24	1
13	17733	KEEPER	2
14	18161	BUMPER-BRUSH COVER 20	1
	18162	BUMPER-BRUSH COVER 24	1
15	03947	RING-RETAINING EXT. 3/8	2
16	16347	BEARING FLANGED BRONZE 3/8	2
17	16671	SCREW-HEX HD CAP 3/8-16 X 5/8 (ZP)	4
18	18558	PLATE-BEARING RETAINING	1
20	00600	SCREW-SLO. RND HD MACH #8-32 X 3/4 (ZP)	2
21	07132	WASHER-SPRING 3/8 (3-WAVE)	2
22	03264	USE #30044WHEEL-3" DIA (3/8" BORE)	2
23	03736	WASHER-PLAIN 3/8 ID (ZP)	2
24	18130	SCREW-HEX HD CAP 3/8-16 X 1-1/2 (ZP)PATCH	2
25	18165	PIN	1
26	06838	SPRING	1
28	02956	NUT-HEX.LOCK(KEPS) # 8-32	2
29	18593	CAP - SCREW THREAD BLACK VINYL	1

Brush Motor & Cover Assembly, Model:99130 24" EZ Floorkeeper - Series L

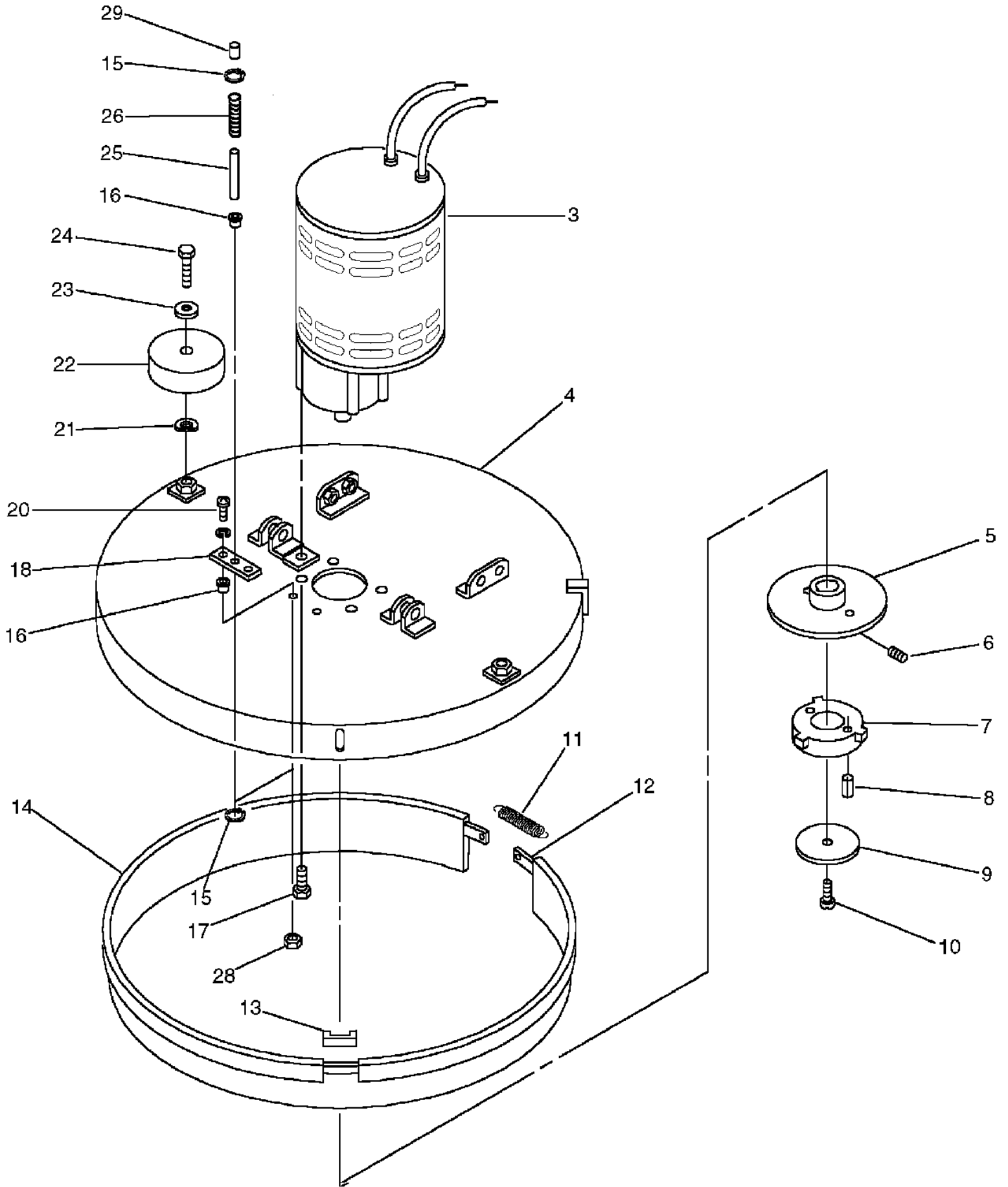

Control / Instrument System

Model :99130 24" EZ Floorkeeper - Series L

	Number	Description	Qty Req.
1	18221	GAUGE-BATTERY CONDITION	1
2	18253	SCREW-T.F.PLT60 PAN HEAD # 8-16 X 3/4	10
3	18218	INDICATOR LIGHT-28V(RE D) EZ	1
4	18217	SWITCH-ROCKER DPST (99105-)28VDC (C.B.)	1
5	18216	SWITCH-ROCKER S.P.S.T. 24VDC(LIGHTED) EZ	2
6	18212	PANEL-INSTRUMENT(EZ)	1
7	15560	NUT-HEX.LOCK(KEPS) # 4-40	2
8	15542	SWITCH LEAF S.P.D.T. 10 AMPS EZ	1
9	18896	HANDLE-CONTROL(EZ-BD)	1
13	18897	SCREW-PHIL. FLAT HD MACH #8-32 X 1-1/4 (ZP)	1
14	02071	SCREW-TCT (T) R.H. #8-32 X 3/8	2
15	18895	WELDMENT-BRUSH ACTUATION LEVER	1
16	18675	BRACKET-DEAD MAN HANDLE STOP	1
18	02956	NUT-HEX.LOCK(KEPS) # 8-32	2
23	08079	SCREW-SOCKET HD SHOULDER 5/16D X 1-1/2 (ZP)	4
24	16075	SCREW-PHIL. PAN HD MACH #8-32 X 1/2 (ZP)	1
25	18346	BLOCK, TERMINAL8 TAB 1/4 Q.D.	1
31	18323	SCREW-PHIL. PAN HD MACH #4-40 X 5/8 (ZP)	2
37	31028	PANEL-CONTROLLER (EZ)	1
40	18364	DECAL SOLUTION CONTROL EZ F/K	1
41	18376	DECAL SQUEEGEE CONTROL EZ F/K	1
42	18385	CAP - SCREW HEAD GRAY VINYL	4
43	18402	GRIP-FOAM CONTROL HANDLE	1
44	18677	SCREW-PHIL. PAN HD MACH #8-32 X 1.00 (ZP)	1
45	18657	SPACER #8	1
49	18660	USE #14142WASHER PLAIN 5/16ID (ZP)	4
52	14827	FLASHER RELAY EZ	1
53	15913	CLAMP 1.13 EZ	1
54	18863	KNOB - PLASTIC 1/4 DIA	1
55	18905	POTENTIOMETER - 5K W/WIRING HARNESS (FK/LR)	1

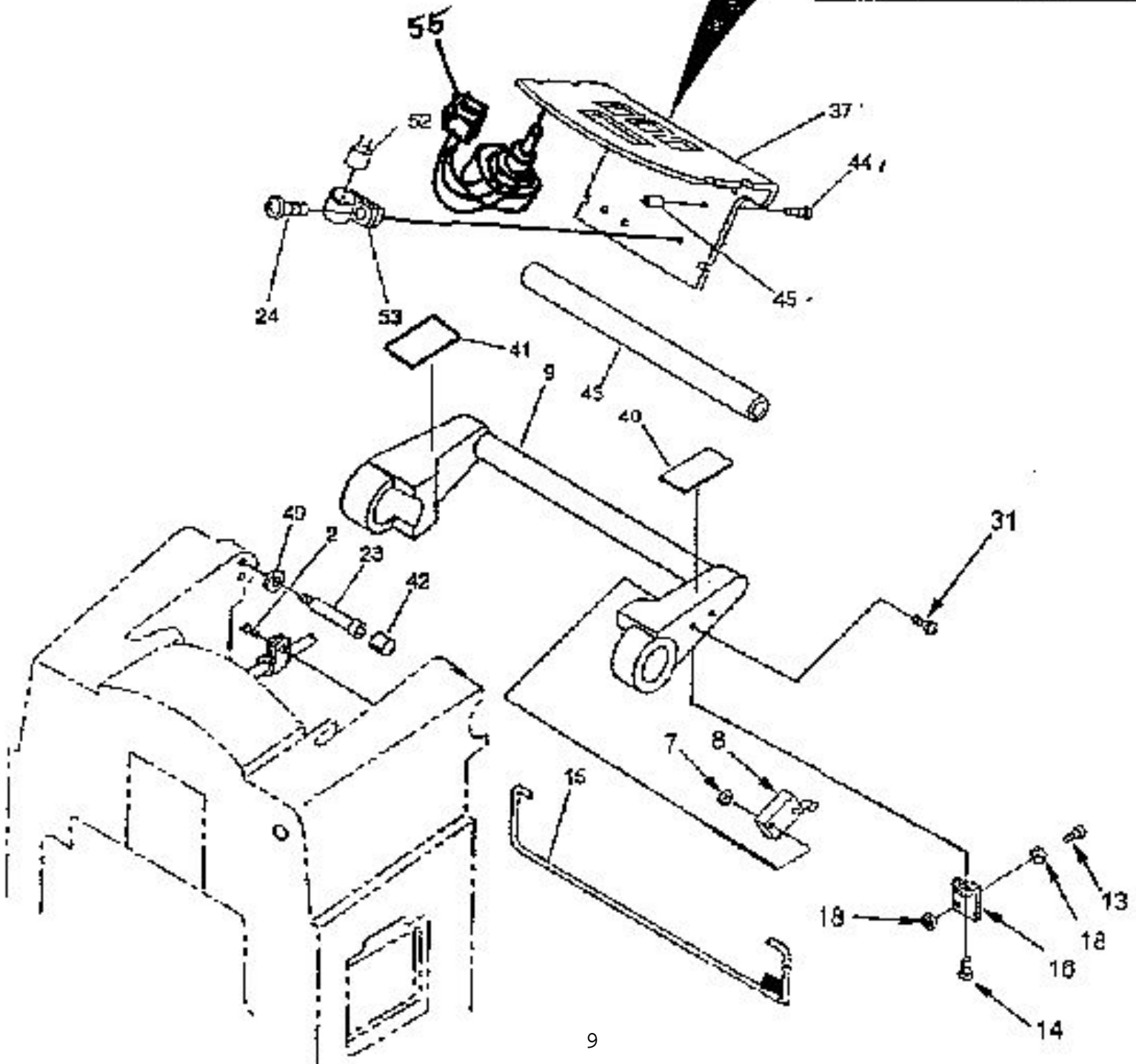
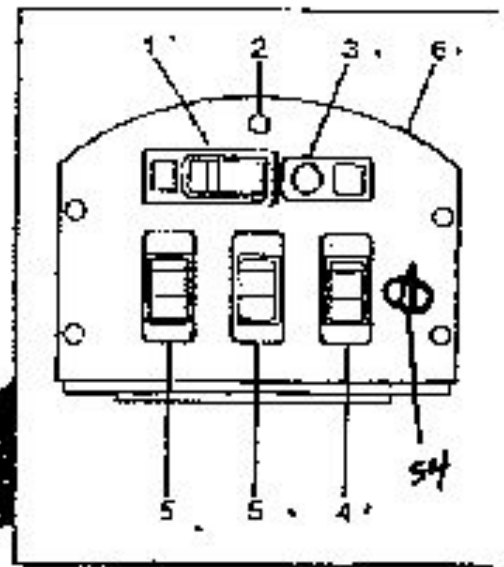

Rear Access Panel W/Relays

Model :99130 24" EZ Floorkeeper - Series L

	Number	Description	Qty Req.
	30830	SPEED CONTROLLER(24V EZ) SVC USE: 32569	1
1	15330	GROMMET 5/8 ID	4
2	06192	SCREW-PHIL. TRUSS HD 1/4-20 X 1/2 (ZP)	8
4	14142	WASHER-PLAIN .265 ID (ZP)	4
5	05427	SCREW-PHIL. RND HD MACH 1/4-20 X 5/8 (ZP)	4
6	01574	WASHER-LOCK(H/S)1/4	4
7	15345	BUSHING INSULATOR	2
9	04442	SCREW-PHIL. PAN HD MACH 1/4-20 X 1/2 (ZP)	8
10	18230	CLIP-RETAINING TUBE	1
13	00128	SCREW-PHIL. RND HD MACH #8-32 X 1/2 (NICK)	2
14	02956	NUT-HEX.LOCK(KEPS) # 8-32	2
15	18468	CLIP-SIGHT TUBE RETAIN	1
16	18255	WELDMENT-RELAY MOUNTING PLATE	1
17	31028	PANEL-CONTROLLER (EZ)	1
18	03660	SCREW-PHIL. PAN HD MACH #10-24 X 7/16 (ZP)	2
19	10894	NUT-HEX.LOCK(P/T) #10-24	2
20	18219	CIRCUIT BREAKER 25 AMP EZ	1
21	18220	CIRCUIT BREAKER 45 AMP EZ	1
22	18355	PLATE-CIRCUIT BREAKER MOUNTING	1
23	15545	NUT-RETAINER 1/4-20 (.093/.126)	4
24	18213	RELAY PWR. CNTCTR 24 VDC S.P.N.O. EZ	2
25	19329	PIN-RETAINING ACCESS PNL (EZ F/K)	4
	18308	PANEL-RELAY ACCESS (99105-130)	1
	30829	RELAY-24VDC EZ	1

Rear Access Panel W/Relays, Model:99130 24" EZ Floorkeeper - Series L

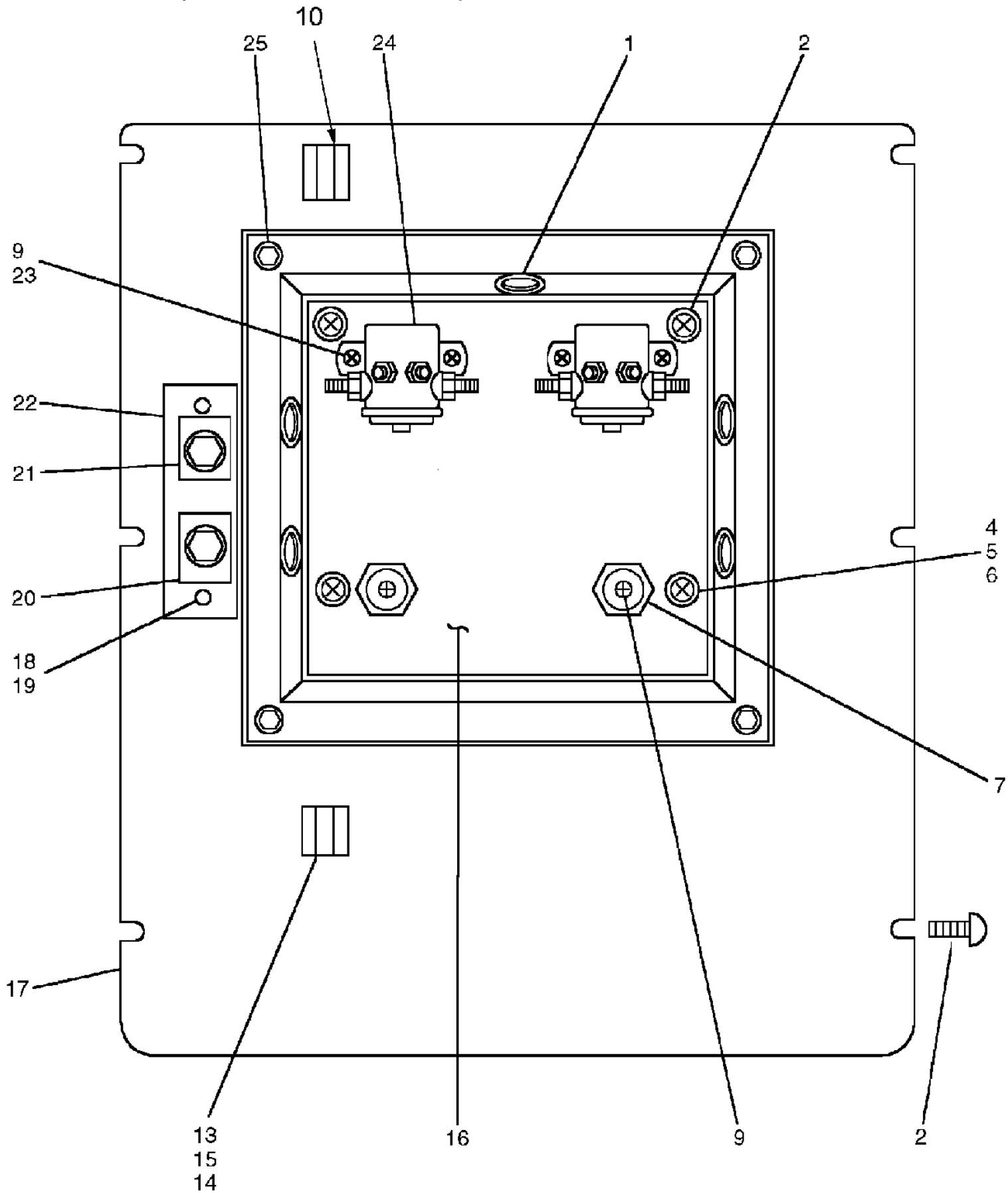

Recovery Tank W/Vac Motor

Model :99130 24" EZ Floorkeeper - Series L

	Number	Description	Qty Req.
1	18741	COVER-REC. TANK ACCESS (EZ)	1
2	18799	ASS'Y INTAKE DEFLECTOR (E/Z)	1
3	15088	ADAPTER - MALE PVC 1-1/2 SCH 40	1
4	18789	ASSEMBLY - CABLE (STEEL) TANK COVER RETN	1
6	18887	ASSEMBLY-FLOAT(EZ)	1
7	18742	GASKET - TANK ACCESS COVER EZ	1
8	18790	CLASP-COVER CABLE	1
9	31235	ASS'Y VAC MOTOR (E/Z)	1
10	05781	GASKET	2
11	15096	FITTING -FEMALE ADAPTER 1-1/2 SCH 40	1
12	18259	SLEEVE-HOSE CUFF ADAPTER	1
13	18477	GROMMET-REAR PANEL (6 IN. LG.)	1
14	18241	BRACKET-SQUEEGEE HOSE SUPPORT	1
15	18747	HOSE-STEEL SUPPORTED BLK 1-1/2 X 56 W/CUFFS	1
16	18253	SCREW-T.F.PLT60 PAN HEAD # 8-16 X 3/4	2
17	18226	PLUG - DRAIN 1-1/2	1
18	18358	STRAP-HOSE PLUG RETAINING	1
19	18357	SLEEVE-RECOVERY DRAIN HOSE	1
20	01734	SCREW-PHIL. RND HD MACH #6-32 X 3/8 (NICK)	6
21	01246	WASHER-LOCK(H/S)# 6	6
22	18671	CLIP - RETAINING DRAIN HOSE	3
23	01905	WASHER-LOCK(E/T C'SUNK) #10	6
24	01993	SCREW-PHIL. FLAT HD MACH #10-24 X 5/8 (ZP)	6
25	18439	PLATE-DRAIN HOSE RET.CLI P MTG.	3
26	19286	HOSE-BELLOW 1-1/2X20LG CP-HOSE ON 99430 SERVICE W/31237	1
27	16091	CLAMP-HOSE(SCREW) 1-1/4-2(LINED)	1
28	18401	SLEEVE-SCH.40 1-1/4 X 1- 1/2	1
29	18052	FITTING-SCH.40 ADAPT.ABS 1-1/4SMPT X 1-1/4FSF	1
30	31990	TANK-RECOVERY(F/K-EZ) NEW FLOAT (YELLOW)	1
31	19398	ASSEMBLY-INTAKE FILTER (EZ VACUUM MOTOR)	1
32	18846	SPACER-(1/4-20)	1
33	17392	CLAMP-CABLE(CCH 5/16)	1
34	18342	SCREW-FLAT HEAD CAP 1/4-20 X 1(SS)(NYLOCK)	2
35	14142	WASHER-PLAIN .265 ID (ZP)	3
36	15183	USE #17177SCR-HEX 1/4-20X1-1/4 SS	1
37	18333	SCREW-PHIL. PAN HD MACH 1/4-20 X 1.00 (ZP)	3
38	18349	SPACER-(1/4-20)	2
40	18847	GASKET-VACUUM MOTOR(EZ) (99105,125,126,130)	1
41	17508	NUT-FINISHED HEX 1/4-20 (SS)	1
42	18885	WASHER-PLAIN 1/4 ID (SS)	1
43	18886	WASHER-PLAIN 2.00 ID (SS)	2
44	18688	BATTERY TRAY(EZ)	1
45	18687	HOSE-STEEL SUPPORTED BLK 2 X 36 NO CUFFS	1
46	18686	MUFFLER-VACUUM MOTOR EXHAUST	1
47	18692	BRACKET-BATTERY SPACING(EZ)12V	1
48	18706	WIRE TIE-15(BLACK)	2
49	14858	CLAMP-HOSE(SCREW) 1-5/16-2-1/4(LINED)	1
50	04651	SCREW-TCT(F)PAN HEAD #10-24 X 1/2	1
51	00851	WASHER-PLAIN 1/4	3
52	98799	BATTERY-12V(FLOODED)	2
53	99506	BATTERY- 6V (FLOODED)	4
54	99510	BATTERY CHARGER-24V/20A W/ RED CON (SB-50)	1
55	18692	BRACKET-BATTERY SPACING(EZ)12V	1
56	30725	CABLE-BATTERY JUMPER 6 GA. X 17 BLACK	2

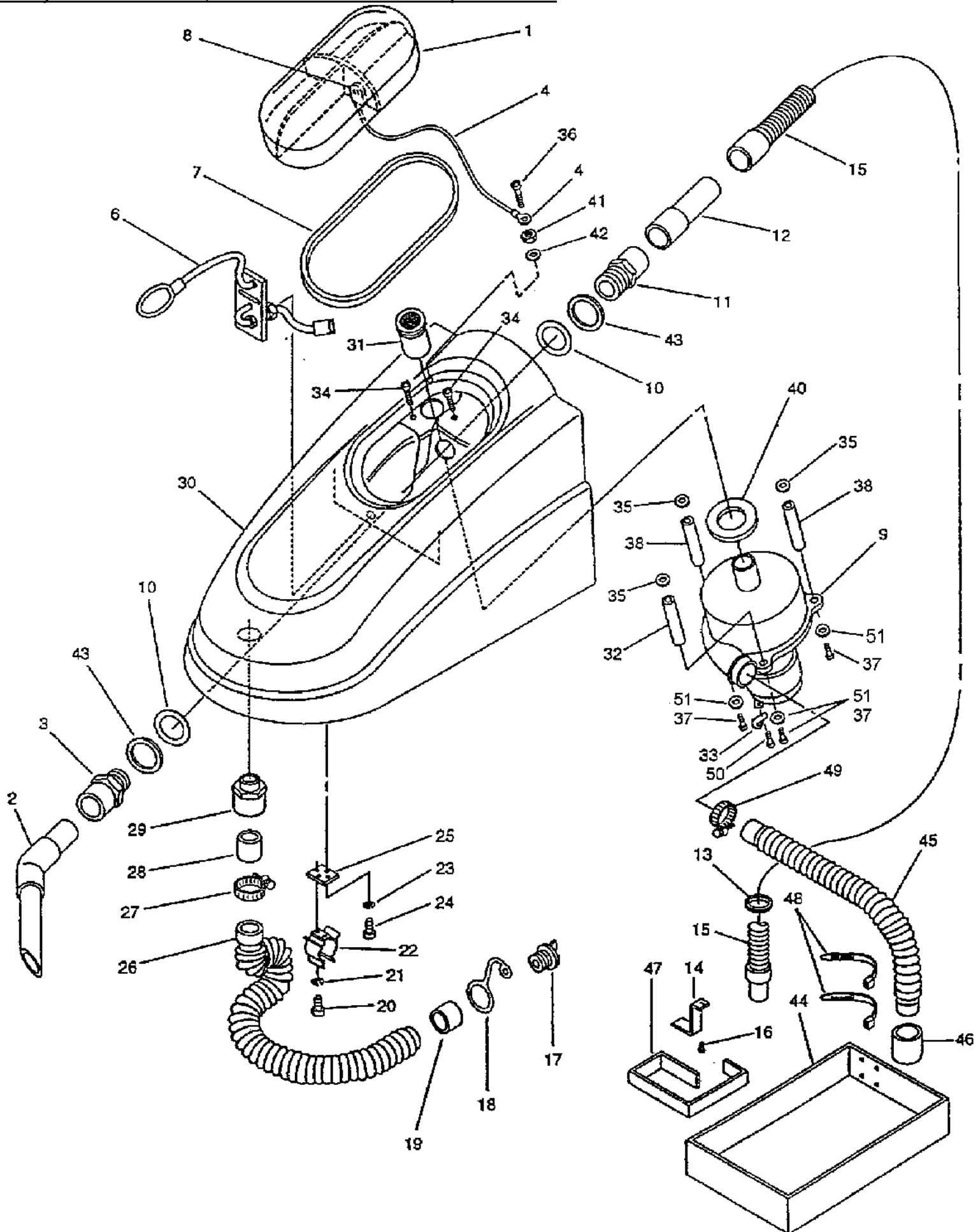

Solution Tank

Model :99130 24" EZ Floorkeeper - Series L

	Number	Description	Qty Req.
3	00128	SCREW-PHIL. RND HD MACH #8-32 X 1/2 (NICK)	3
4	31264	ASS'Y GROUND WIRE (MARATHON 800/1200)	1
5	18230	CLIP-RETAINING TUBE	2
6	02956	NUT-HEX.LOCK(KEPS) # 8-32	3
7	03320	SCREW-HEX HD CAP 3/8-16 X 1.00 (ZP)	1
8	18652	BRACKET-SOL. CONTROL PIVOT MOUNTING	1
9	04442	SCREW-PHIL. PAN HD MACH 1/4-20 X 1/2 (ZP)	2
10	18328	PLATE-SOLUTION CONTROL	1
11	18261	PIN-SOLUTION CONTROL LIN KAGE	3
12	18316	RING-RETAINING EXT. 3/8	8
13	18329	BAR-LOWER SOL. CONTROL LINK	1
14	15677	SCREW-SOCKET HD SHOULDER 3/8D X 3/8 (ZP)	1
15	18486	FITTING - PLASTIC ELBOW 3/8 NPT X 3/8	1
16	18457	COVER-SOLUTION FILL KIT (99105,125-130)	1
17	07626	CLAMP-HOSE (SCREW) 5/16-7/8	3
18	18684	BRACKET-SOL. VALVE RETAINING (E/Z)	1
19	07533	NUT-HEX.LOCK(P/T) 1/4-20	2
20	31253	VALVE-BALL (E/Z)	1
21	18485	FITTING - PLASTIC CPLR 3/8 NPT X 3/8	1
22	31646	HOSE-1/2ID X 15 (CLEAR) NYLON BRAID REINF PVC	1
24	03736	WASHER-PLAIN 3/8 ID (ZP)	2
25	31648	FITTING-RUN TEE (BRASS) 3/8MPT X 3/8FPT X 3/8FPT	1
26	18253	SCREW-T.F.PLT60 PAN HEAD # 8-16 X 3/4	2
27	18207	TANK SOLUT.(NO OPENING) (F/K-EZ) YELLOW	1
28	18466	PLATE-SOLUTION LEVER STOP	1
29	18262	PIN-SOLUTION CONTROL LIN KAGE	1
30	18330	BAR-UPPER SOL. CONTRL LI NK 031	1
31	03868	NUT-HEX JAM LOCK (NYL) 3/8-16 (ZP)	1
32	18319	WELDMENT-SOL. CNTRL. HANDLE	1
33	16347	BEARING FLANGED BRONZE 3/8	2
34	18249	BRACKET-HANDLE PIVOT (99105-130)	1
35	16136	SCREW-TFT(PLT30)FIL.HD. #13-9 X 3/4	3
36	10894	NUT-HEX.LOCK(P/T) #10-24	2
37	18431	TUBE-SOLUTION RELEASE 31USE 32643	1
	18433	TUBE-SOLUTION RELEASE 32USE 32643	1
38	01589	NUT-FINISHED HEX W/ LOCTITE 5/16-18 (ZP)	1
39	01246	WASHER-LOCK(H/S)# 6	1
40	16581	WASHER-PLAIN .563 ID (SS)	2
41	01577	WASHER-LOCK(H/S)5/16 (REGULAR)	4
42	18339	SCREW-PHIL. FLAT HD MACH #10-24 X 3/4 (SS)	2
44	16031	SCREW-HEX HD CAP 5/16-18 X 1-1/2 (ZP)	4
45	18229	HINGE 1/4 DIA PIN X 3 X 18	1
46	18251	USE #10721GRIP - HANDLE	1
47	18308	PANEL-RELAY ACCESS (99105-130)	1
48	18359	ASSEMBLY - CABLE (STEEL) VACUUM TANK STOP(EZ)	1
49	30816	DECAL-TORNADO W/ LOGO 2.25 WIDE X 9.50 LG. BLK	1
53	18377	DECAL-BATT.CHRGNG.INSR.	1
54	18381	DECAL CIRCUIT BREAKER IDENTIFICATION	1
55	15734	GAGE COLOR	1
56	06192	SCREW-PHIL. TRUSS HD 1/4-20 X 1/2 (ZP)	10
57	14544	SCREW-PHIL. FLAT HD MACH #6-32 X 7/8 (ZP)	2
58	30812	DECAL-LOGO SWIRL 3.625 DIA. BLACK	1
59	17376	NUT-HEX.LOCK #10-24(NYLON)	2
60	18237	CONNECTOR-HOUSING SB-50 RED	1
61	18239	PLATE-CHARGER CONN. MOUNTING	1
62	18240	BRACKET-WARNING LIGHT MNT.	1
63	18253	SCREW-T.F.PLT60 PAN HEAD # 8-16 X 3/4	4
64	18309	SCREW-PHIL. PAN HD MACH #10-24 X 1/2 (ZP)	2
65	18336	SCREW-PHIL. PAN HD MACH #10-24 X 1/2 (NYLON)	2
67	05427	SCREW-PHIL. RND HD MACH 1/4-20 X 5/8 (ZP)	2
68	18849	LABEL-WIRING DIAGRAM (99125-130) 115V	1
70	18642	WASHER-PLAIN .281 ID (ZP)	4

Solution Tank

Model :99130 24" EZ Floorkeeper - Series L

	Number	Description	Qty Req.
71	03321	WASHER-PLAIN .391 ID (ZP)	4
72	18859	ASSEMBLY-EZ WARNING LIGHT	1
73	15639	#194 LAMP	2
75	18717	CLAMP-CABLE(5/8DIA.)	2
76	18309	SCREW-PHIL. PAN HD MACH #10-24 X 1/2 (ZP)	2
77	10892	NUT-HEX.LOCK(KEPS) #10-24	2
78	19945	SCREW-TRUSS HEAD 1/4-20 X 5/8	1
79	31649	FITTING-ADAPTER (BRASS) 3/8MPT X 5/8HB	1
80	31647	FITTING-ELBOW (BRASS) 3/8MPT X 1/2HB	1
81	31645	FITTING-ADAPTER (BRASS) 3/8MPT X 1/2HB	1

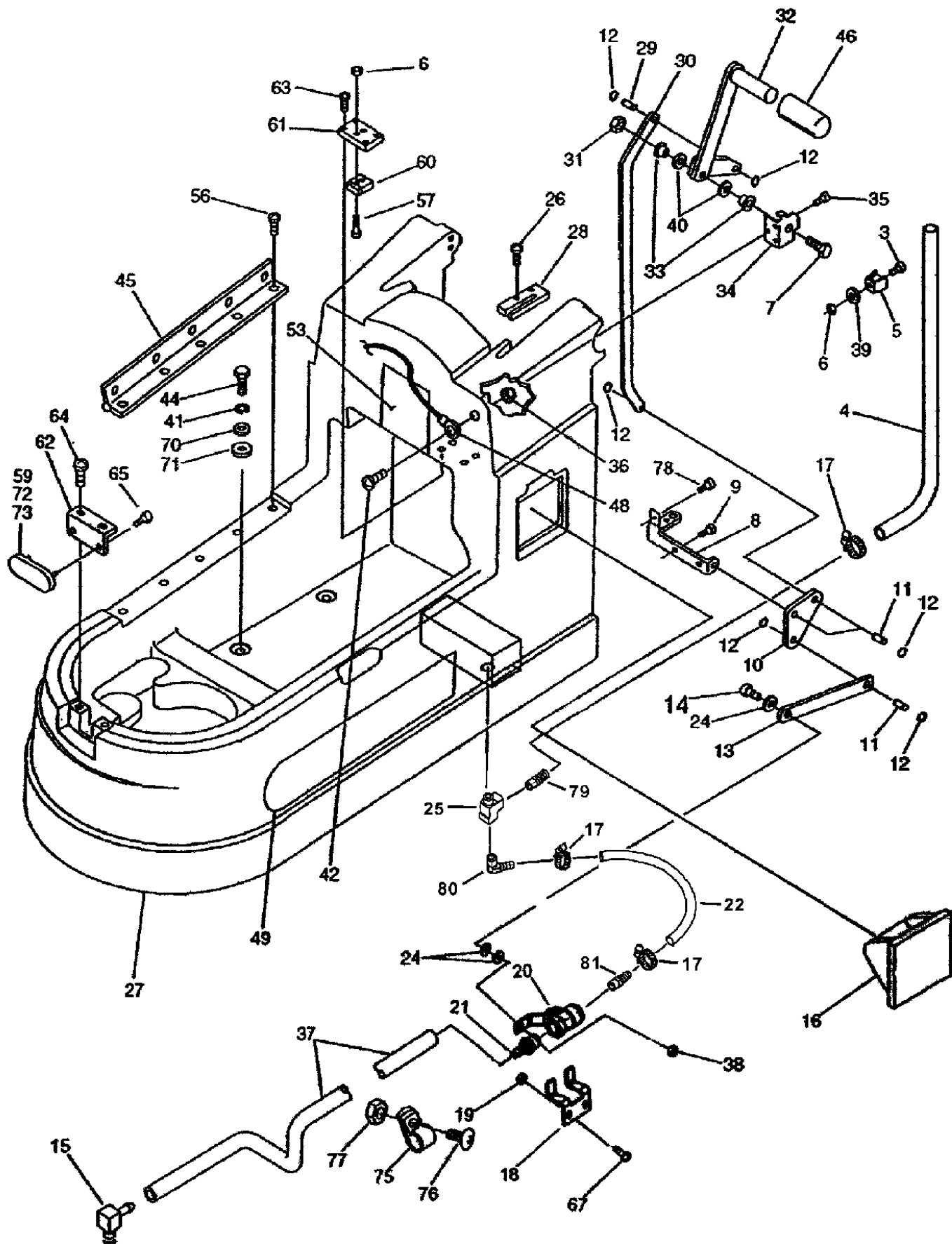

Squeegee Assembly

Model :99130 24" EZ Floorkeeper - Series L

	Number	Description	Qty Req.
1	03868	NUT-HEX JAM LOCK (NYL) 3/8-16 (ZP)	1
2	16581	WASHER-PLAIN .563 ID (SS)	2
3	18314	WELDMENT-SQGE CNTRL. HANDLE	1
4	16347	BEARING FLANGED BRONZE 3/8	2
5	18655	NUT-PUSH ON RETAINER CAP 3/16	1
6	16136	SCREW-TFT(PLT30)FIL.HD. #13-9 X 3/4	5
7	18817	BRACKET-HANDLE PIVOT(EZ) (99125,126,130)	1
8	03320	SCREW-HEX HD CAP 3/8-16 X 1.00 (ZP)	1
9	19910	ASSEMBLY - CABLE SQUEEGEE LIFT	1
10	03660	SCREW-PHIL. PAN HD MACH #10-24 X 7/16 (ZP)	2
11	18651	PLATE-CONTROL CABLE CLAS P	1
12	10894	NUT-HEX.LOCK(P/T) #10-24	2
13	30227	PIN-COTTER (EXT.PRONG) 5/64 X 1/2 STL ZP	2
14	18400	WHEEL- 1-5/8DIA. BLACK/RUBBER	2
15	30226	PIN-CLEVIS .320 DIA / 1-1/4LONG	2
16	00696	WASHER-PLAIN #10 ID (ZP)	4
17	17130	NUT-ACORN LOCK(P/T) 1/4-20	2
18	17400	SPACER-1/4	2
19	11053	WHEEL- 4DIA.(3/8BORE) BLACK(15/16WIDTH)	2
20	07132	WASHER-SPRING 3/8 (3-WAVE)	2
21	18136	CHANNEL-OUTER(28SQGEE)	1
	18137	CHANNEL-OUTER 32 SQUEEGEE E	1
22	18710	SQUEEGEE BLADE SET (EZ-24)	1
23	18663	RETAINER-30SQGEE.BLADE	1
	18664	SQUEEGEE BLADE RETAINER (34)	1
24	18680	SCREW-FLAT HEAD CAP 1/4-20 X 2-1/4(SS)	2
26	18681	SCREW-FLAT HEAD CAP 5/16-18 X 1-3/4(SS)	2
27	03320	SCREW-HEX HD CAP 3/8-16 X 1.00 (ZP)	1
28	16586	WASHER-LOCK(I/T)3/8	1
29	03914	WASHER-PLAIN .443 ID (BRASS)	1
30	18145	BEARING-THRUST 5/8 (BRON ZE)	1
31	18146	PIVOT STAINLESS	1
32	18141	WELDMENT-TOWING ARM (99105-) PLUS 2 SUBPARTS	1
33	18119	KNOB - PLASTIC INSERT 5/16-18	3
35	01577	WASHER-LOCK(H/S)5/16 (REGULAR)	4
36	18111	SCREW-HEX HD CAP 5/16-18 X 5/8 (SS)	4
37	18142	SHAFT-PIVOT	1
38	16254	PIN-COTTER 1/8 DIA X 1 E/P	1
39	16347	BEARING FLANGED BRONZE 3/8	2
40	18114	WELDMENT - PIVOT FRAME	1
41	18144	WELDMENT-PIVOT FRAME	1
42	18568	SPRING-EXTENSION	1
43	18138	SPRING ADJUSTER	1
44	18176	PIN-SPRING SLTD 1/8 DIA X 1-1/4	1
45	18206	WELDMENT-SQUEEGEE WHEEL SUP'T.	1
46	18650	BRACKET-SQUEEGEE CABLE MOUNTING	1
47	18251	USE #10721GRIP - HANDLE	1
48	18253	SCREW-T.F.PLT60 PAN HEAD # 8-16 X 3/4	3
49	18548	BRACKET-SQUEEGEE LEVER S TOP	1
50	14142	WASHER-PLAIN .265 ID (ZP)	4
51	01574	WASHER-LOCK(H/S)1/4	1
52	01497	NUT-FINISHED HEX 1/4-20 (NICK)	1
53	18695	BOLT - SQUEEGEE LIFT CABLE MTG.	1
54	15560	NUT-HEX.LOCK(KEPS) # 4-40	2
55	18323	SCREW-PHIL. PAN HD MACH #4-40 X 5/8 (ZP)	2
56	18818	SWITCH BUTTON S.P.D.T. 10 AMPS EZ	1
57	03301	USE #14142WASHER-5/16 (ZP)	4
58	19796	PLATE-CONTROL CABLE CLASP	1
59	00851	WASHER-PLAIN 1/4	2

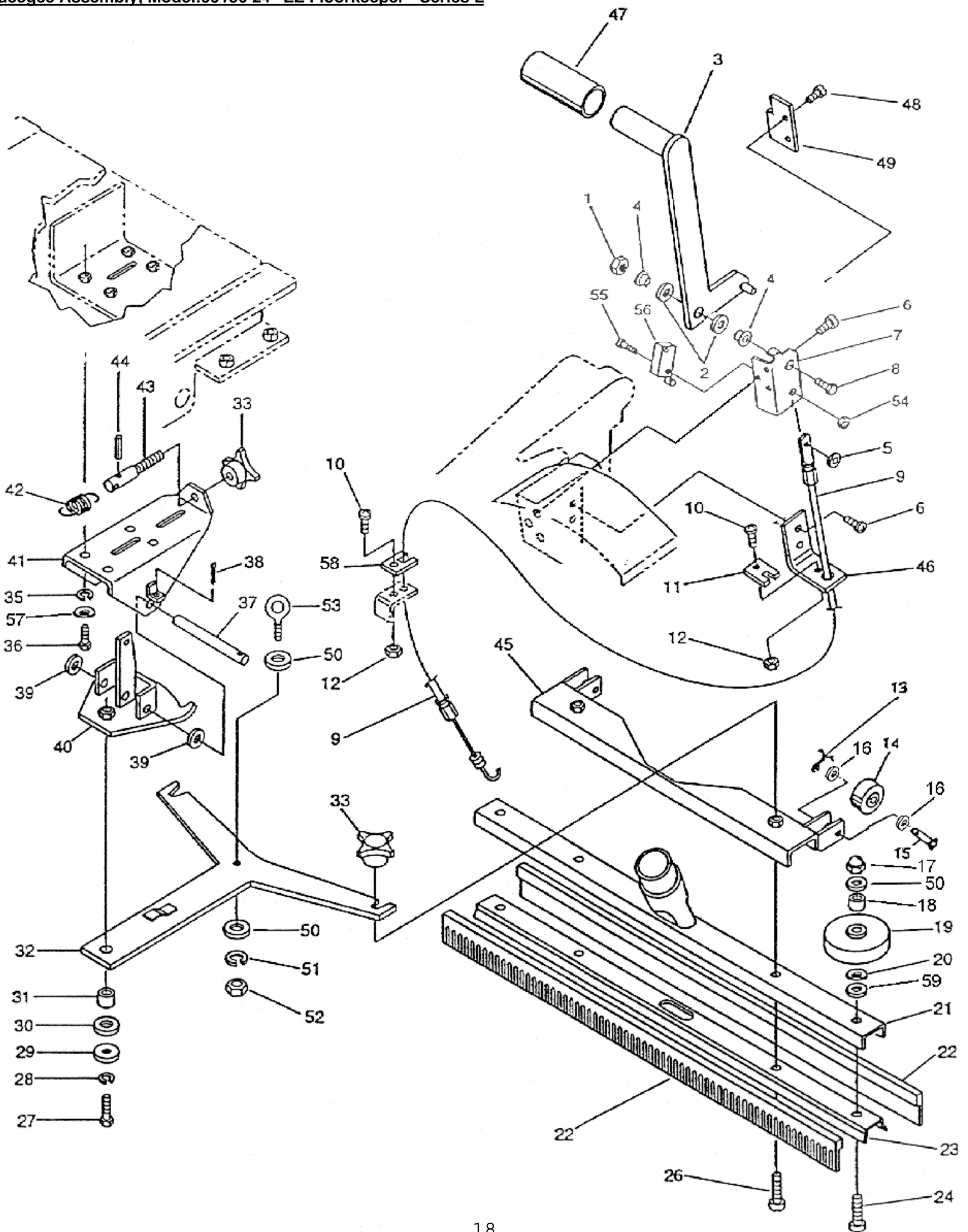

Traction Drive Assembly

Model :99130 24" EZ Floorkeeper - Series L

	Number	Description	Qty Req.
1	19283	CHASSIS-EZ FLOORKEEPERS	1
2	18079	CASTER SWIVEL 4 DIA (EZ)	2
3	03301	USE #14142WASHER-5/16 (ZP)	8
4	01577	WASHER-LOCK(H/S)5/16 (REGULAR)	8
5	18111	SCREW-HEX HD CAP 5/16-18 X 5/8 (SS)	8
7	03536	WASHER-LOCK(H/S)3/8	2
8	18104	SCREW-HEX HD CAP 3/8-16 X 3/4 (ZP) PATCH	2
9	03321	WASHER-PLAIN .391 ID (ZP)	2
10	18509	WHEEL 8 DIA	2
11	19258	USE 32923TRNSAXLE-24VDC,1/4HP 12A	1
14	18115	KEY-SQUARE 3/16 X 1 LG.	2
15	16031	SCREW-HEX HD CAP 5/16-18 X 1-1/2 (ZP)	4
16	01574	WASHER-LOCK(H/S)1/4	4
17	05427	SCREW-PHIL. RND HD MACH 1/4-20 X 5/8 (ZP)	4
18	19294	RETAINER-EZ TRANSAXLE	2
20	02956	NUT-HEX.LOCK(KEPS) # 8-32	4
21	10892	NUT-HEX.LOCK(KEPS) #10-24	4
22	18309	SCREW-PHIL. PAN HD MACH #10-24 X 1/2 (ZP)	4
23	03960	WASHER-PLAIN 25/32 ID (ZP)	2
	24422	CARBON BRUSH-TRANSAXLE (19258) SERVICE PART	2
	24423	CAP BRUSH-TRANSAXLE (19258) SERVICE PART	2

