

# Main Assembly

Model :97575 28" ProGlazer Series D

	Number	Description	Qty Req.
1	01574	WASHER-LOCK(H/S)1/4	4
2	01577	WASHER-LOCK(H/S)5/16 (REGULAR)	10
3	01734	SCREW-PHIL. RND HD MACH #6-32 X 3/8 (NICK)	3
4	02046	SCREW-HEX HD CAP 1/4-20 X 1.00 (ZP)	8
5	02047	SCREW-HEX HD MACH 1/4-20 X 5/8 (NICK)	2
6	02217	NUT-HEX JAM LOCK (NYL) 1/4-20 (ZP)	17
7	02958	NUT-HEX.LOCK(KEPS) # 6-32	3
8	03124	RIVET-BLIND CEBM 3/16 D X .656	5
9	03218	WASHER-PLAIN 1/4 ID (ZP)	7
10	03536	WASHER-LOCK(H/S)3/8	1
11	03736	WASHER-PLAIN 3/8 ID (ZP)	1
12	04054	PLUG-HOLE 11/16DIA. STEEL	1
13	10677	SCREW-TFT (A) P.H. #10-12 X 1/2	4
14	12812	SCREW-HEX HD CAP 5/16-18 X 1-3/4 (ZP)	4
15	12896	SCREW-PHIL. RND HD MACH #10-32 X 5/8 (ZP)	6
16	12957	WASHER-PLAIN 1/2 ID (ZP)	4
16	14142	WASHER-PLAIN .265 ID (ZP)	16
17	14142	WASHER-PLAIN .265 ID (ZP)	16
18	15061	CLAMP-NOZZLE BAR	1
19	15378	SCREW-PHIL. PAN HD MACH #10-24 X 1-3/4 (ZP)	2
20	15666	SPACER SQUEEGEE LIFT	3
21	15887	RETAINER-PAD (BIG-MOUTH) (GLZRS) USE KIT# 90599	1
22	16069	SCREW-FLAT HD.SOCKET CAP 5/16-18 X 1-1/4	8
23	17177	SCREW-HEX HD CAP 1/4-20 X 1-1/4 (SS)	4
24	18641	SCREW-HEX HD CAP 1/4-20 X 1-3/4 (ZP)	1
25	18666	WASHER-PLAIN .500 ID (ZP)	1
26	18875	SCREW-HEX HD CAP 1/2-13 X 1-3/4 (ZP)	2
27	19145	NUT-HEX LOCK (NYL.INS.) #10-24 (SS)	2
28	19337	NUT-HEX LOCK (NYL.INS.) 1/2-13 (ZP)	2
29	19513	NUT-HEX LOCK (NYL.INS.) 5/16-18 (ZP)	14
30	19666	BRIDGE PIN 1/2DIA.	2
31	30274	DECK-MACHINED 28 PROPANE	1
32	30278	PAD GRIPPER-HANDLE DELUX (PROPANE)	1
33	30280	HANDLE-UPPER DELUXE ASSY (PROPANE) PAINT BLACK	1
34	30293	WELDMENT-LOWR.HANDL.ASSY (PROPANE) BLACK PAINT	1
35	30311	PAD DRIVER 28 INCH	1
36	30313	BRACKET-WHEEL (HRS/BLK) (PROPANE)	2
37	30314	WHEEL-6 GREY (PROPANE)	2
38	30315	PIN-CLEVIS (WHEEL) 5/16D X 2.6 LG (ZP)	2
39	30316	SPACER-WHEEL 3/8 (NYLON)	8
40	30319	PIN-COTTER .12 X 2.37(ZP)	2
41	30324	PAD-BEIGE(ULTRA H/S)28 (97560)	1
42	30331	PULLEY-24 CAST IRON (PROPANE 24)	1
43	30332	BUSHING-PULLEY (PROPANE)	1
44	30335	WASHER-PLAIN 7/16 ID (ZP)	7
45	30340	WASHER-SPRING LOCK 7/16	4
46	30341	WASHER-SPRING LOCK 1/2	2
47	30354	SCREW-HEX HD CAP 1/4-20 X 5/8 (ZP)	2
48	30355	CASTER-3 GREY (PROPANE)	1
49	30356	WASHER-LOCK(E/T) 1/2 (ZP)	4
50	30358	NUT-HEX LOCK (NYL.INS.) #10-32 (ZP)	6
51	30363	WELDMENT-BATTERY TRAY (PROPANE) PAINT BLACK	1
52	30367	FELT SIDE-BATTERY TRAY (PROPANE)	2
53	30368	FELT BACK-BATTERY TRAY (PROPANE)	1
54	30370	BRACKET-BATTERY (C.R.S) (PROPANE) PAINT BLACK	1
55	30371	WELDMENT-BATTERY COVER (PROPANE) PAINT BLACK	1
56	30374	COVER BATTERY (BACK) (PROPANE) PAINT BLACK	1
57	30375	LATCH-PROPANE TANK (PROPANE)	1
58	30377	FELT TANK-RET. BACK (PROPANE)	1
59	30384	SCREW-SOCKET HEAD HEX 5/16-18 X 1(BLCK OXIDE)	2
60	30394	THROTTLE CONTROL (PROPANE)	1
61	30396	TANK-PROPANE(STEEL) (ALL PROPANES)	1

## Main Assembly

Model :97575 28" ProGlazer Series D

	Number	Description	Qty Req.
62	30400	TRIM-GUARD RAIL (76) (97560) CHROME	1
63	30414	SWITCH-KEY (PROPANE)	1
64	30609	KEY-SHAFT (ZP) (PROPANE)	1
65	30614	KEY-STOCK 1/4SQ X 1LG (PROPANES) (ZP)	1
66	30662	ASSY-BELT TENSION(PURCH) (PROPANE)	1
67	30663	DECAL ON/OFF (97560 555 550 540)	1
68	30666	PIN (W/RING) LOCKING BRIDGE PIN (ZP) 3/8 OD	2
69	30814	DECAL-TORNADO W/ LOGO 1.75 WIDE X 7.25 LG. BLK	2
70	31127	SCREW-HEX HD CAP 3/8-16 X 2-3/4 (ZP)	1
71	31399	HOUR-METER (MANUAL) (PROPANES)	1
71	31158	COUPLING-TANK (97430-)	1
72	31160	HOSE-FUEL	1
74	31445	SPACER-BELT TENSIONER (PROPANE)	1
75	31453	RELAY-12V DC 4-TERMINAL (PROPANE) 80AMPS	1
76	31547	BOX-BASE KEY/METER (PROPANE)	1
77	31548	BOX-COVER KEY/METER (PROPANE)	1
78	31848	BELT-DRIVE (PROPANE) B48	1
79	31937	WIREFORM FILTER CAGE (97570 97575 KAWASAKI)	1
80	31970	FILTER-BONNET 6 (FOAM) ENGINE TOP (KAWASAKI)	1
81	32119	BUSHING (ENGINE) PROPANES	1
82	32208	FRONT END ASS'Y (PLASTIC) PROPANES	1
83	32214	SCREW-PHIL. OVAL HD MACH 1/4-20 X 1.50 LG. (SS)	6
84	32268	ENGINE-KAWASAKI 17HP MODEL FH541V (CONVERTED)	1
85	32303	CONVERTER-CATALYTIC PALLADIUM- ENGINE 32268	1
86	32305	MANIFOLD EXHAUST	1
87	32401	BATTERY-12V/18AH(PROPANE (AGM CONSTRUCTION)	1
88	32403	KIT-17HP KAWASAKI ENGINE CONVERSION (541V)	1
89	32405	SPACER-#10 X .4 LG. .194 ID X .25 OD	2
90	32406	WOOD BLOCK(BATTERY STOP) 2X8X1-7/8 FOR P/N 32401	1
91	32476	PULLEY (ENGINE) PROPANES 4.45 OD (BK47H)	1
92	32481	SCREW-HEX HD CAP 7/16-20 X 2.00 (ZP)	1
93	32482	SCREW-HEX HD CAP 7/16-14 X 1-1/2 (ZP)	4
94	18706	WIRE TIE-15(BLACK)	2
95	30681	OIL-SAE 30(1 QUART) (PROPANE ENGINES)	1.5
96	31785	LABEL EMISSIONS COMPLI- ANT PROPANES/KAWASAKI	1
97	32506	KAWASAKI/BROWN FUEL SYS WIRING DIAGRAM	1
98	32507	WIRING HARNESS-STANDARD KAWASAKI	1

Main Assembly, Model:97575 28" ProGlazer Series D

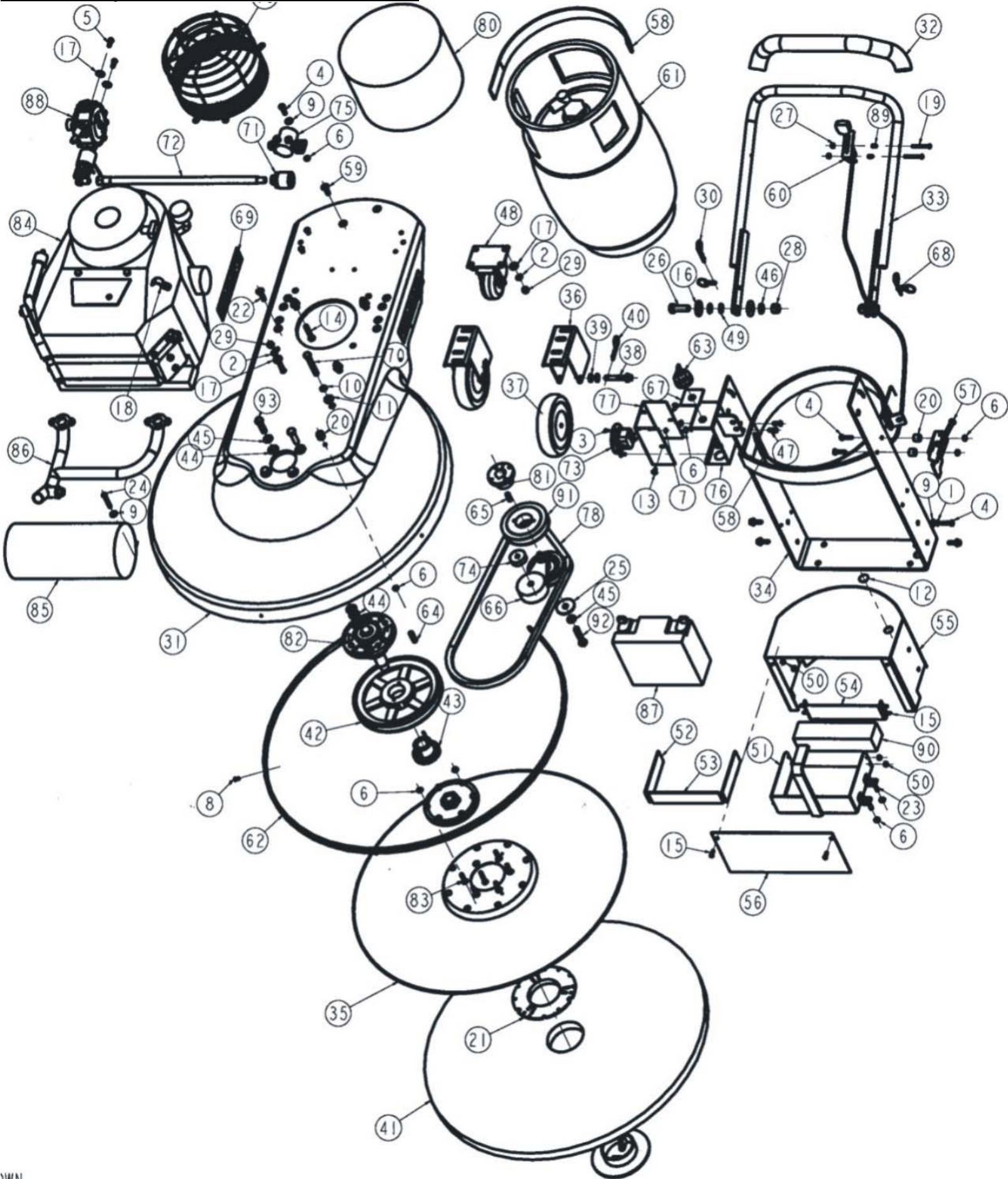

OWN

**Wiring Diagram - Gas Regulator (w/Oxygen Sensor), Model:97575 28" ProGlazer Series D**

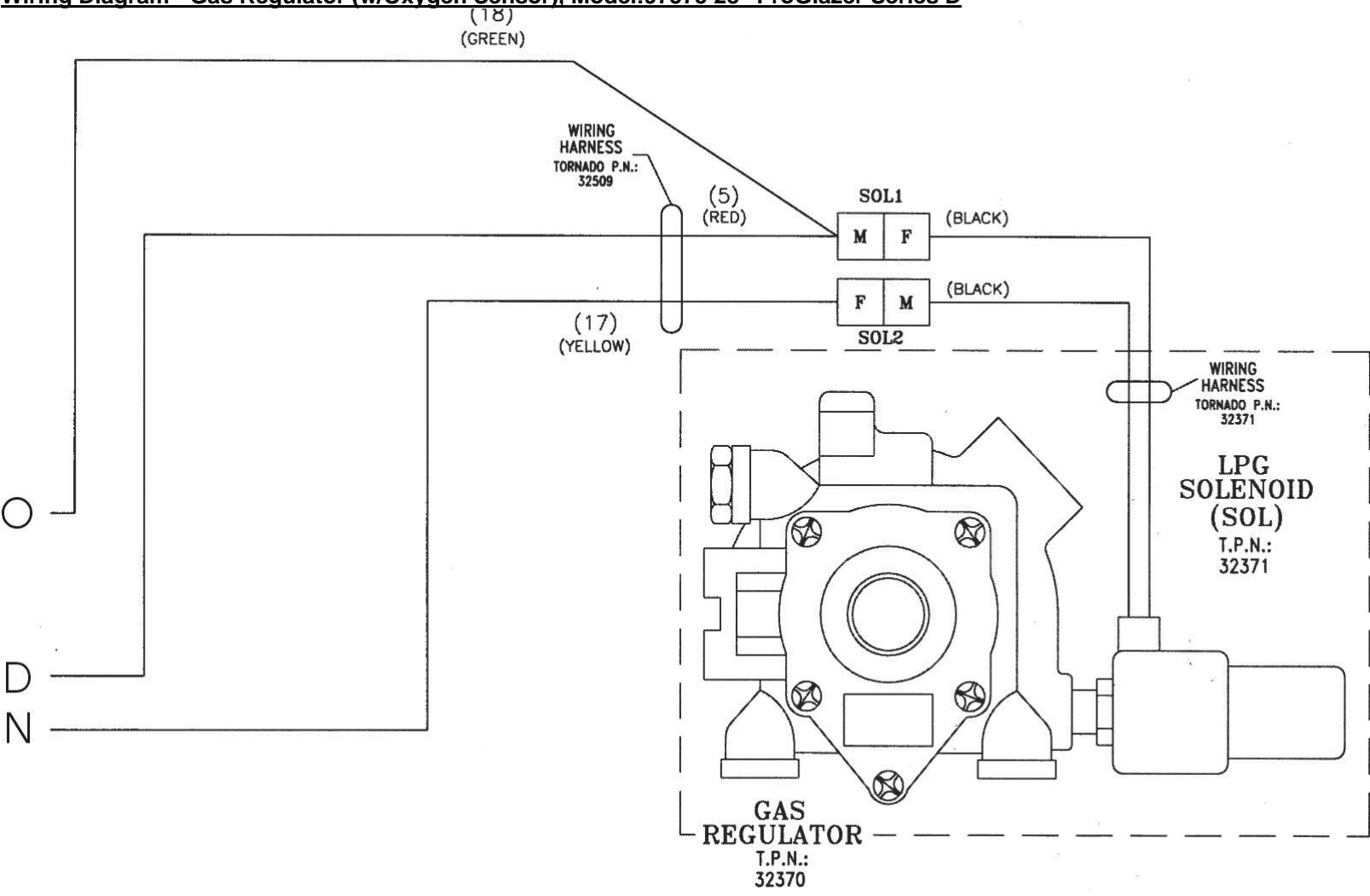

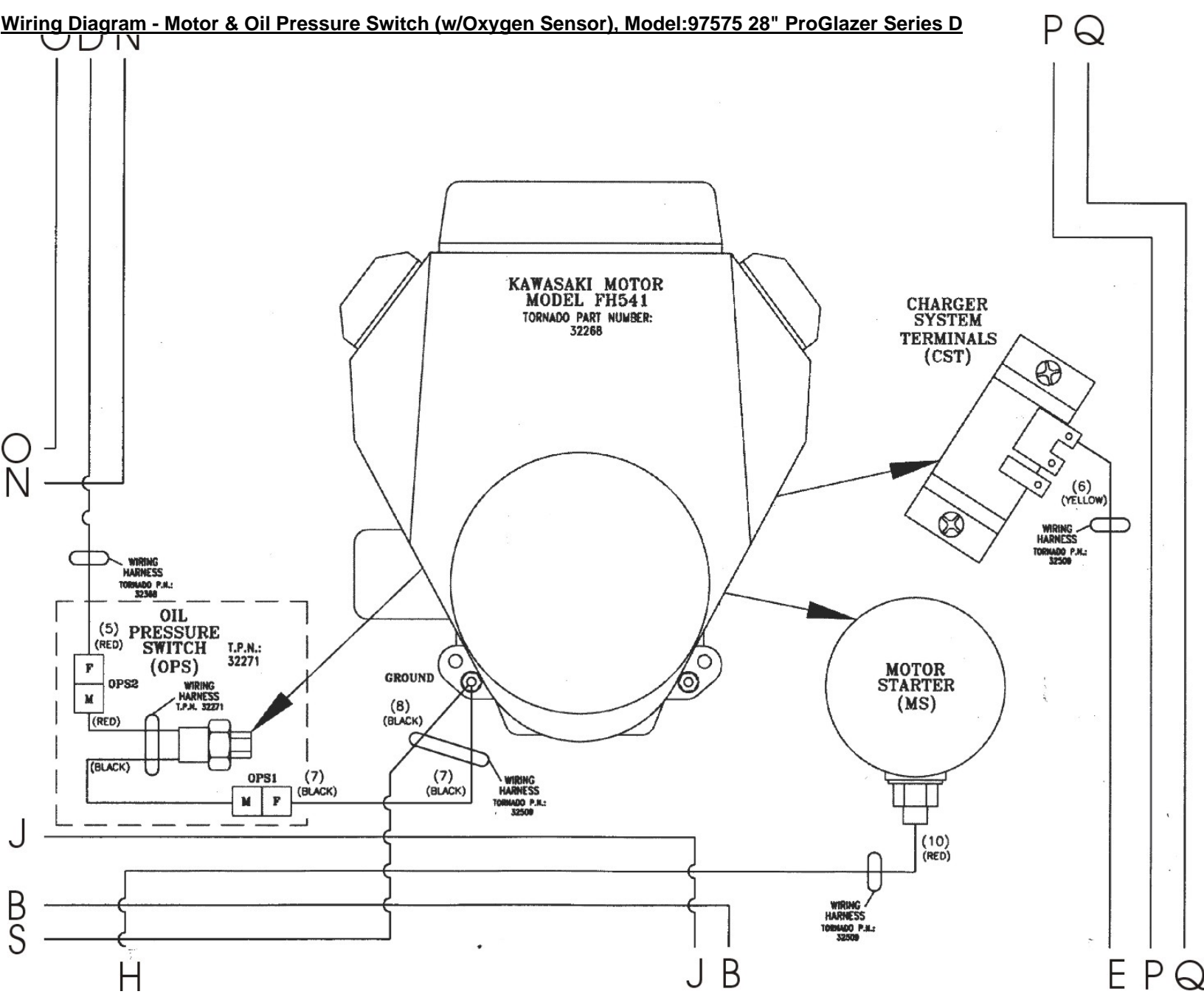

**Wiring Diagram - Oxygen Sensor (w/Oxygen Sensor), Model:97575 28" ProGlazer Series D**

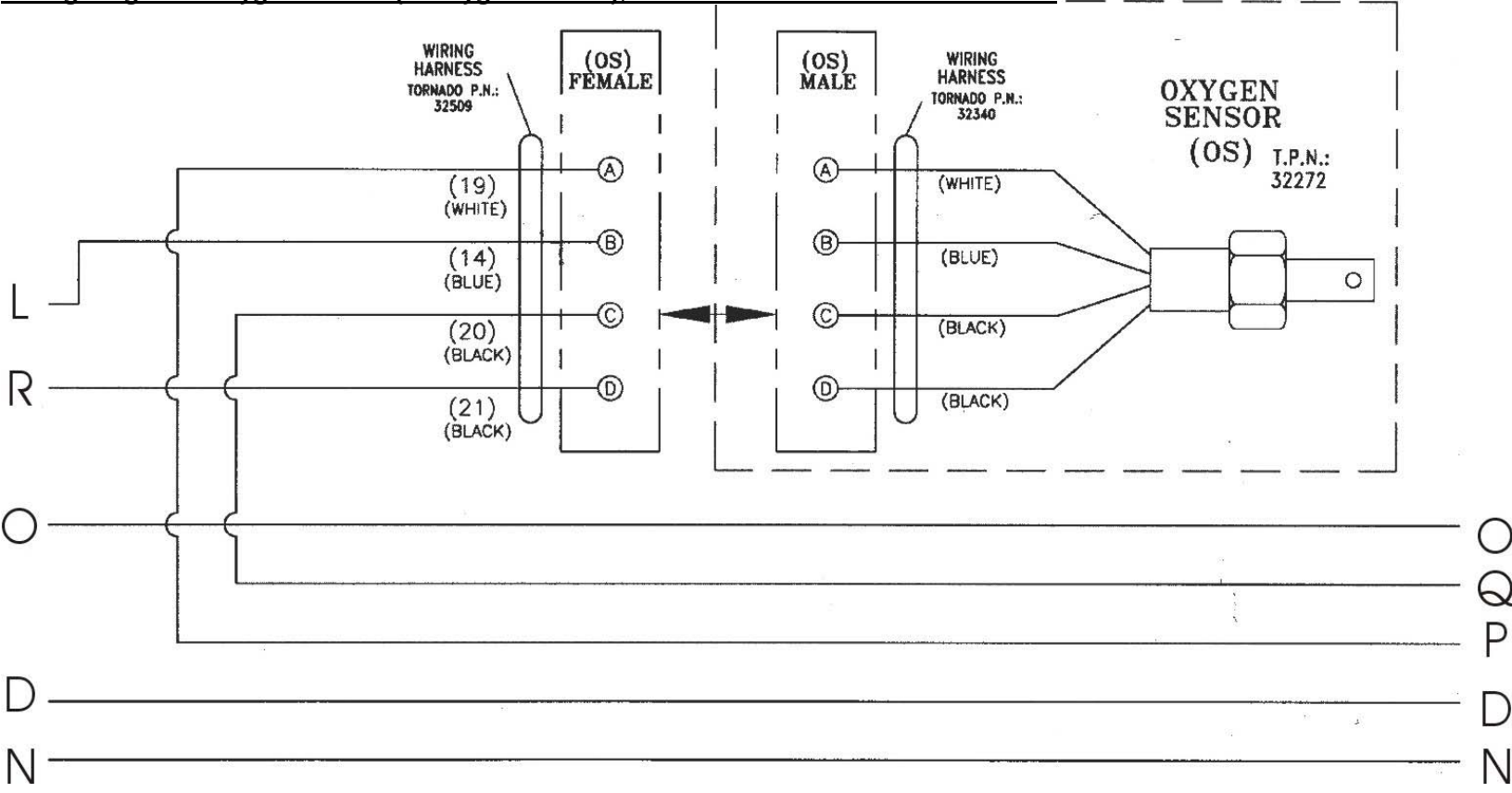

Wiring Diagram - Side Control Panel (w/Oxygen Sensor), Model:97575 28" ProGlazer Series D

SIDE CONTROL PANEL

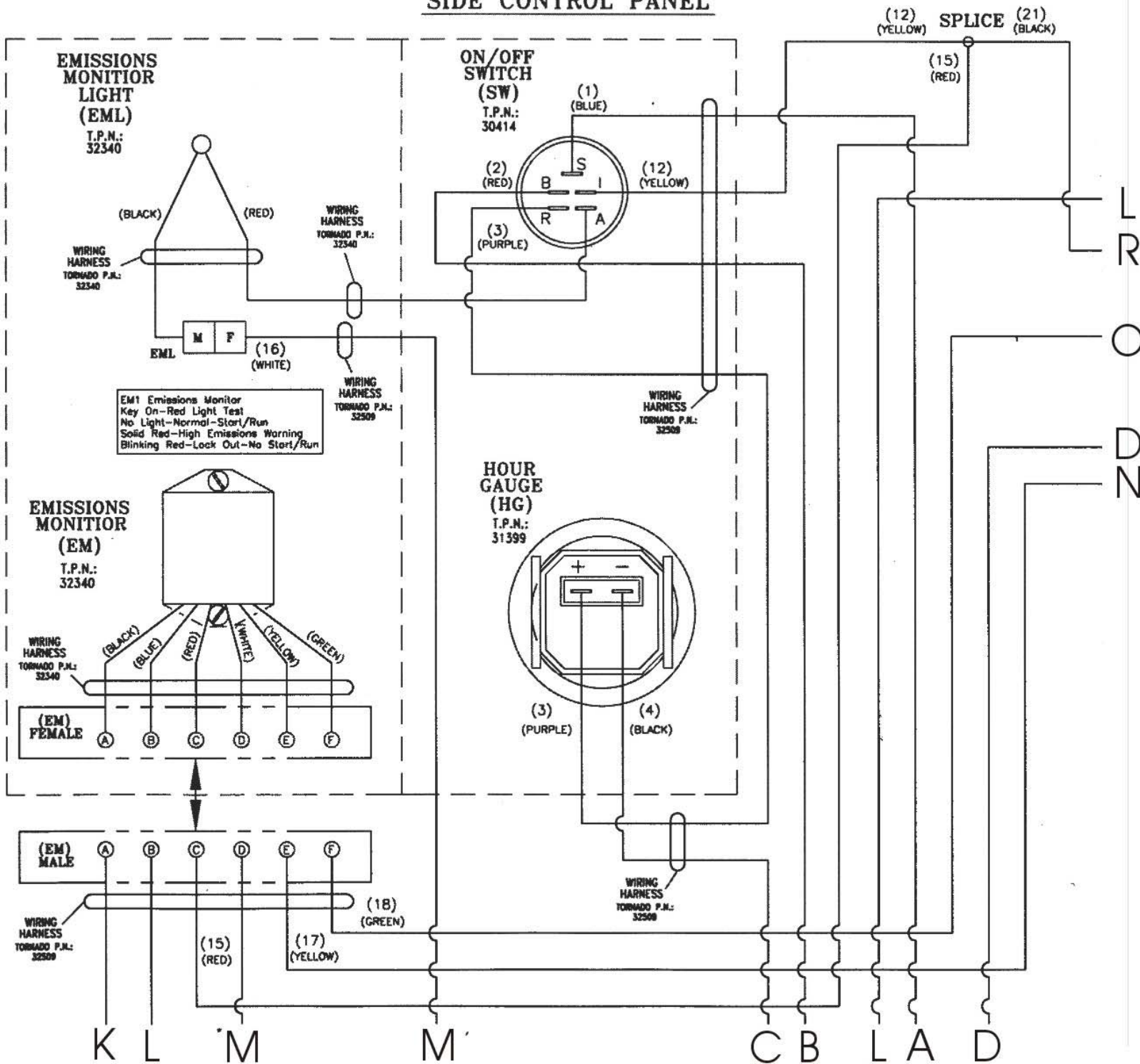

**Wiring Diagram - Starter Relay (w/Oxygen Sensor), Model:97575 28" ProGlazer Series D**

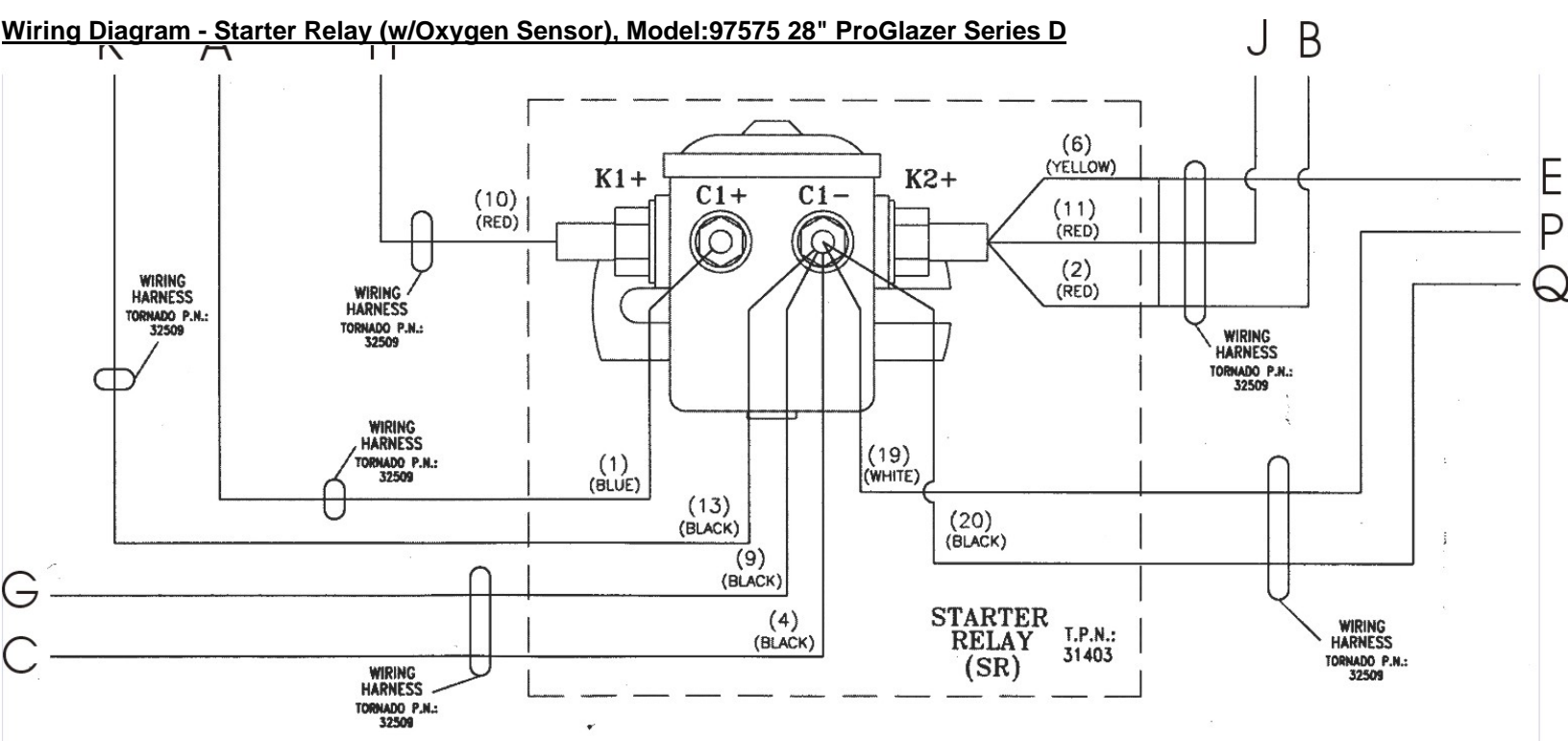



## WIRE TABLE

		WIRE NO'S	AWG	TYPE	COLOR	FROM	TO
WIRING HARNESS TORNADO PART #: 32507	1	14	UL1015		BLUE	SW(S)	SR(C1+)
	2	14	UL1015		RED	SW(B)	SR(K2+)
	3	14	UL1015		PURPLE	SW(R)	HG(+)
	4	14	UL1015		BLACK	HG(-)	SR(C1-)
	5	14	UL1015		RED	SPLICE	OPS2
	6	14	UL1015		YELLOW	SR(K2+)	CST
	7	14	UL1015		BLACK	GROUND	OPS1
	8	6	UL1015		BLACK	GROUND	TE-
	9	14	UL1015		BLACK	SR(C1-)	TE-
	10	6	UL1015		RED	MS	SR(K1+)
	11	6	UL1015		RED	SR(K2+)	TE+
	12	14	UL1015		BLACK	SW(I)	SPLICE
	13	14	UL1015		RED	SPLICE	SOL2
	14	14	UL1015		BLACK	SOL1	SRC1-

**Wiring Diagram - Gas Regulator, Model:97575 28" ProGlazer Series D**

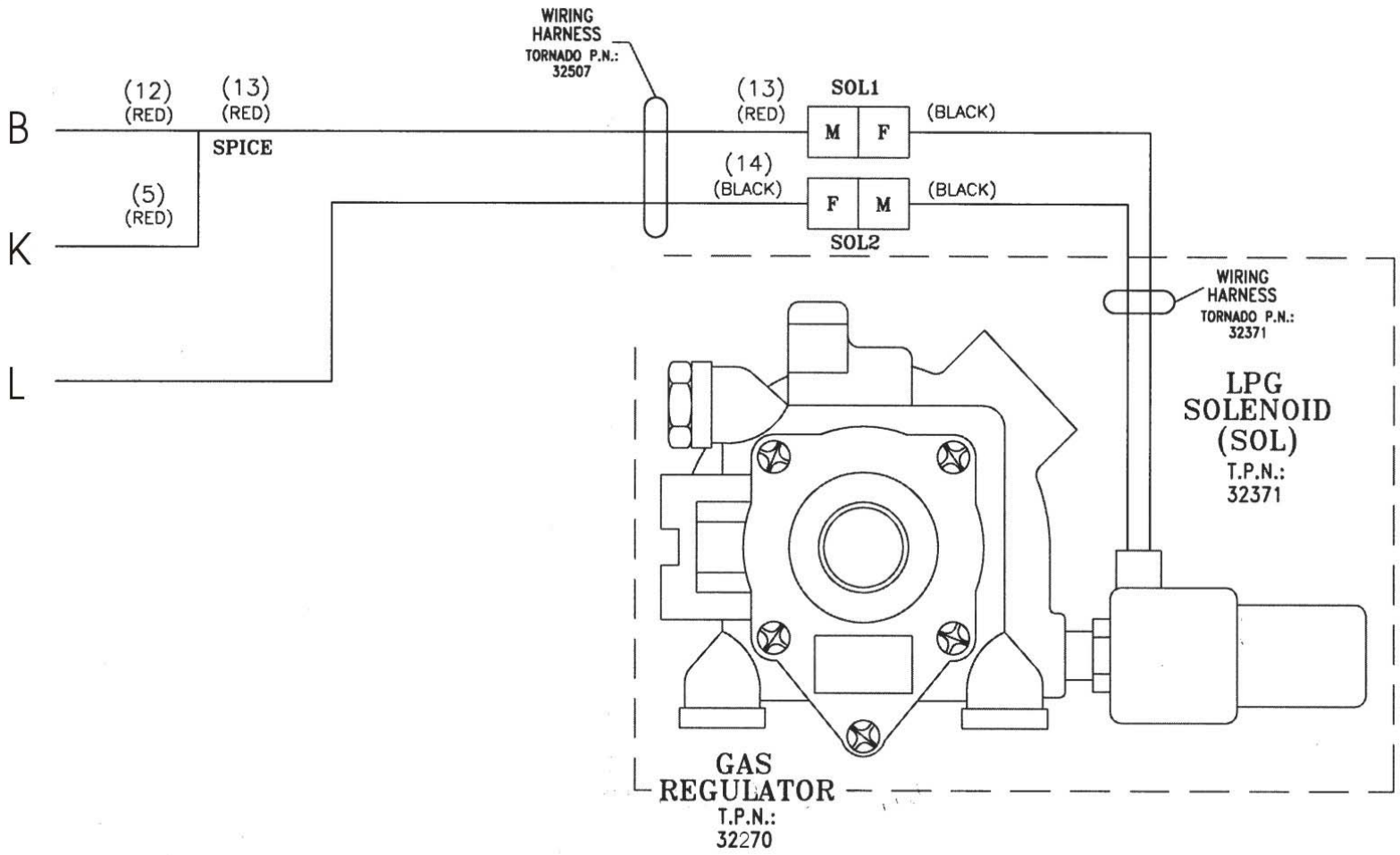

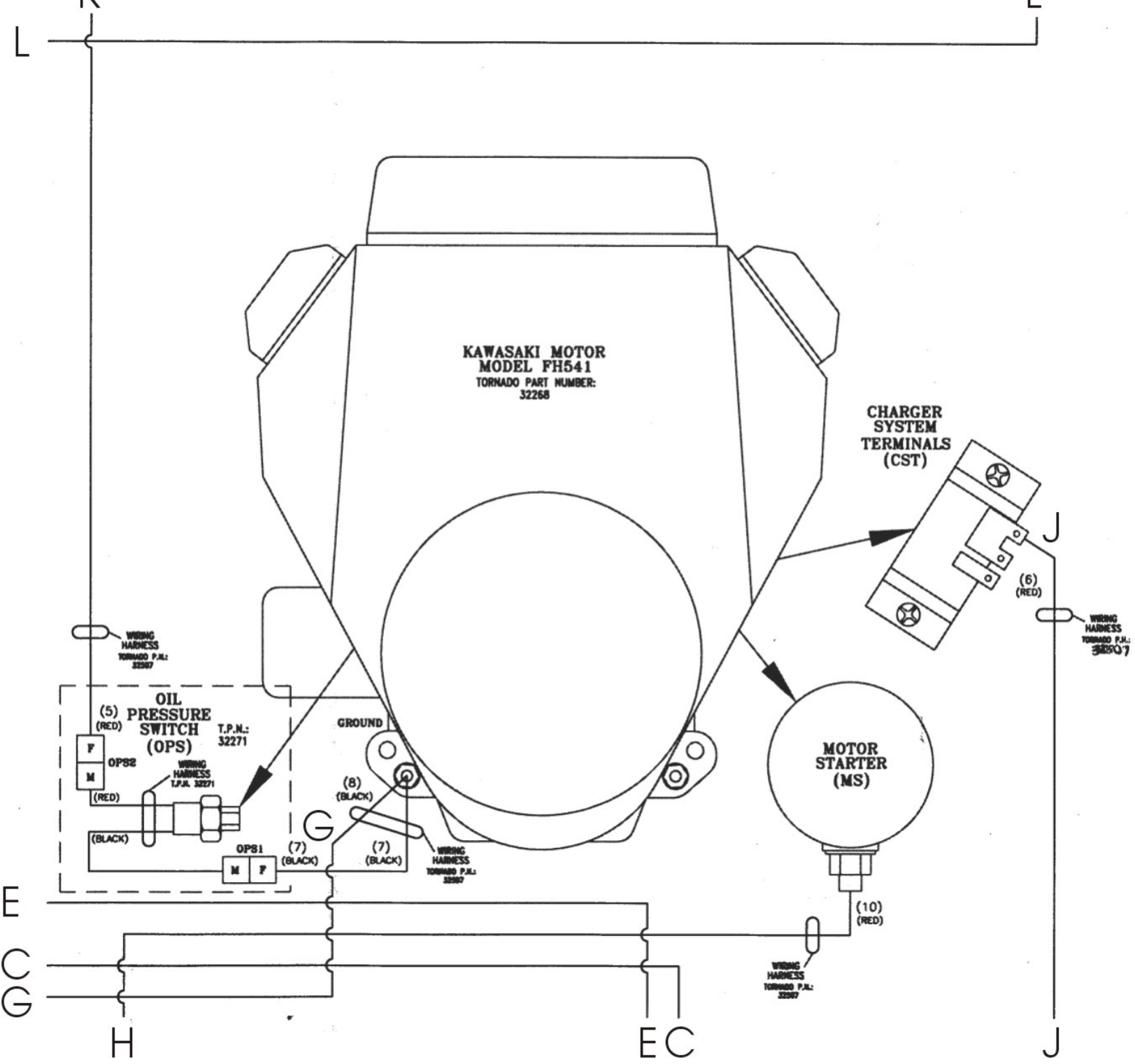

# SIDE CONTROL PANEL

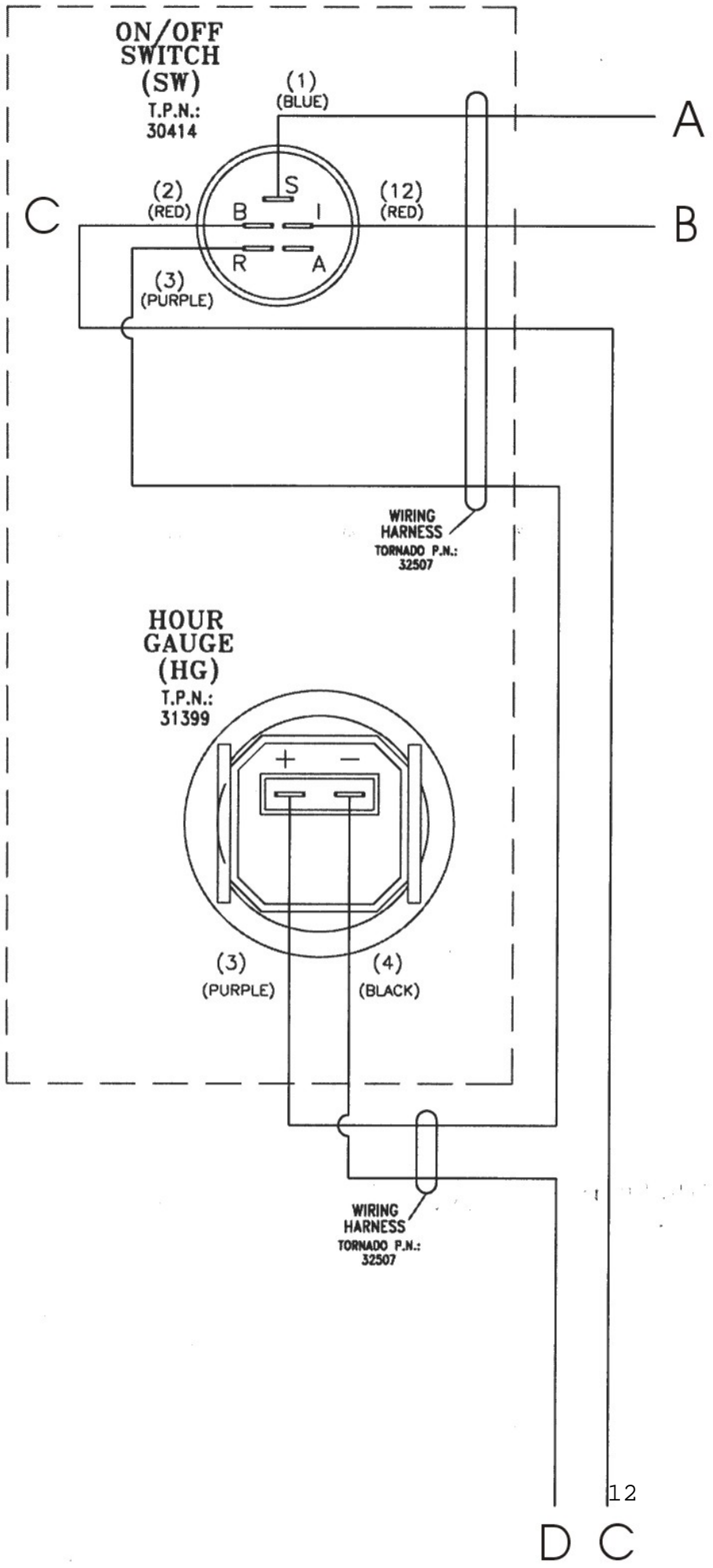

**Wiring Diagram - Starter Relay, Model:97575 28" ProGlazer Series D**

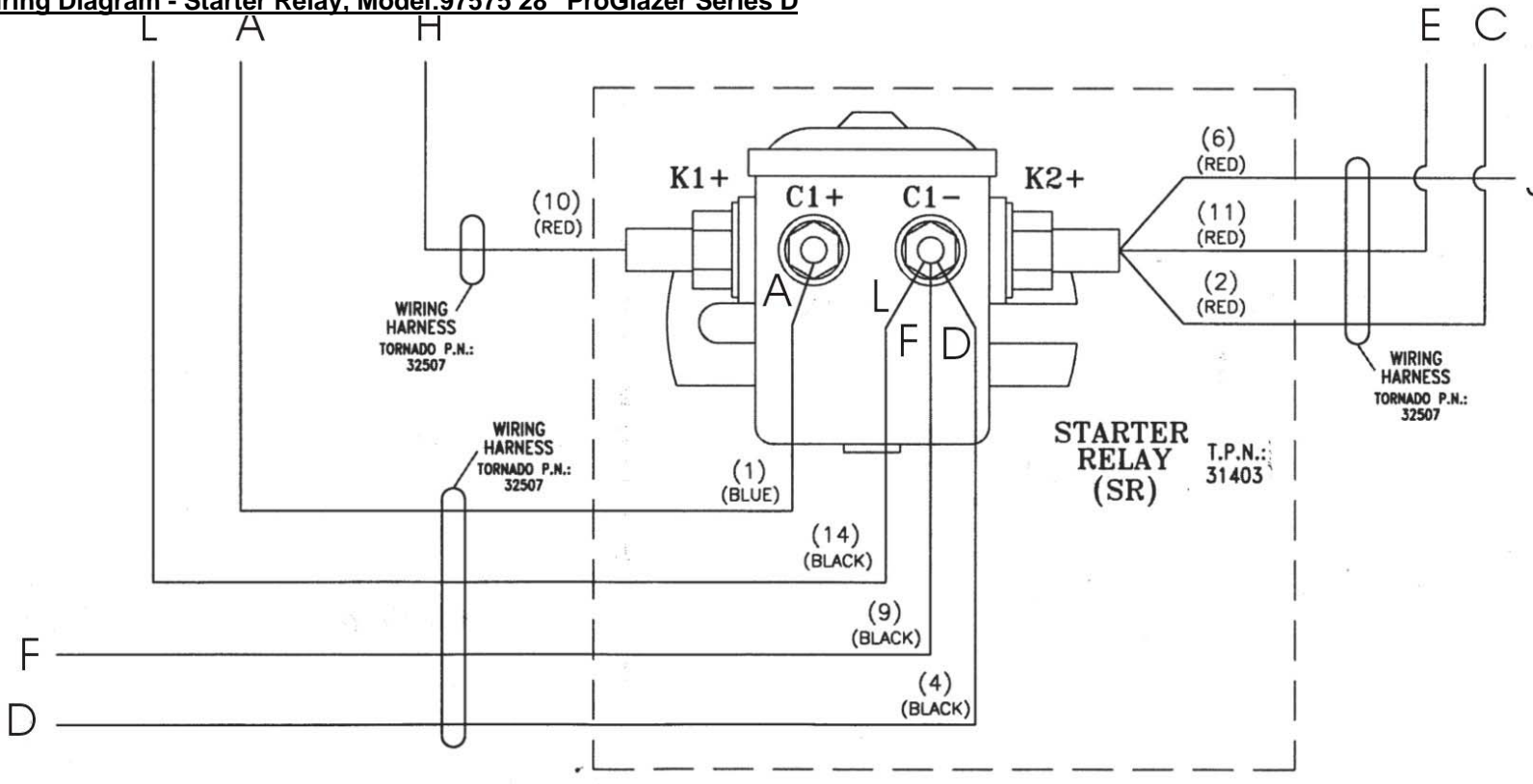

## 32410 Oxygen Sensor Kit

Model :97575 28" ProGlazer Series D

	Number	Description	Qty Req.
1	10677	SCREW-TFT (A) P.H. #10-12 X 1/2	2
2	14560	WIRE TIE- 7(WHITE)	6
3	15245	TERMINAL-RING #10 X 16/14GA.(INSUL.)	3
4	19503	TERMINAL-Q.D.FEMALE 1/4 X 22/18GA.(FUL.INS)	1
5	31506	TERMINAL-Q.D.MALE RED 1/4 X 22/18GA.(FUL.INS)	5
6	32340	SENSOR OXYGEN PROPANE (BROWN) W/WIRING HARNESS	1



Innovative Cleaning Systems

Call Toll-free: 1-800-VACUUMS



## **32410 Oxygen Sensor Kit**

		WIRE TABLE					
		WIRE NO'S	AWG	TYPE	COLOR	FROM	TO
WIRING HARNESS TORNADO PART #: 32509		1	14	UL1015	BLUE	SW(S)	SR(C1+)
		2	14	UL1015	RED	SW(B)	SR(K2+)
		3	14	UL1015	PURPLE	SW(R)	HG(+)
		4	14	UL1015	BLACK	HG(-)	SR(C1-)
		5	14	UL1015	RED	SOL1	OPS2
		6	14	UL1015	YELLOW	SR(K2+)	CST
		7	14	UL1015	BLACK	GROUND	OPS1
		8	18	UL1015	BLACK	GROUND	TE-
		9	14	UL1015	BLACK	SR(C1-)	TE-
		10	6	UL1015	RED	MS	SR(K1+)
		11	6	UL1015	RED	SR(K2+)	TE+
		12	14	UL1015	YELLOW	SW(I)	SPLICE
		13	14	UL1015	BLACK	EMPA	SR(C1-)
		14	14	UL1015	BLUE	OSPB	EMPB
		15	14	UL1015	RED	EMPC	SPLICE
		16	14	UL1015	WHITE	EMPD	EML
		17	14	UL1015	YELLOW	EMPE	SOL2
		18	14	UL1015	GREEN	EMPF	SOL1
		19	14	UL1015	WHITE	SR(C1-)	OSPA
		20	14	UL1015	BLACK	SR(C1-)	OSPC
		21	14	UL1015	BLACK	OSPD	SPLICE



FRONT  
OF  
MACHINE

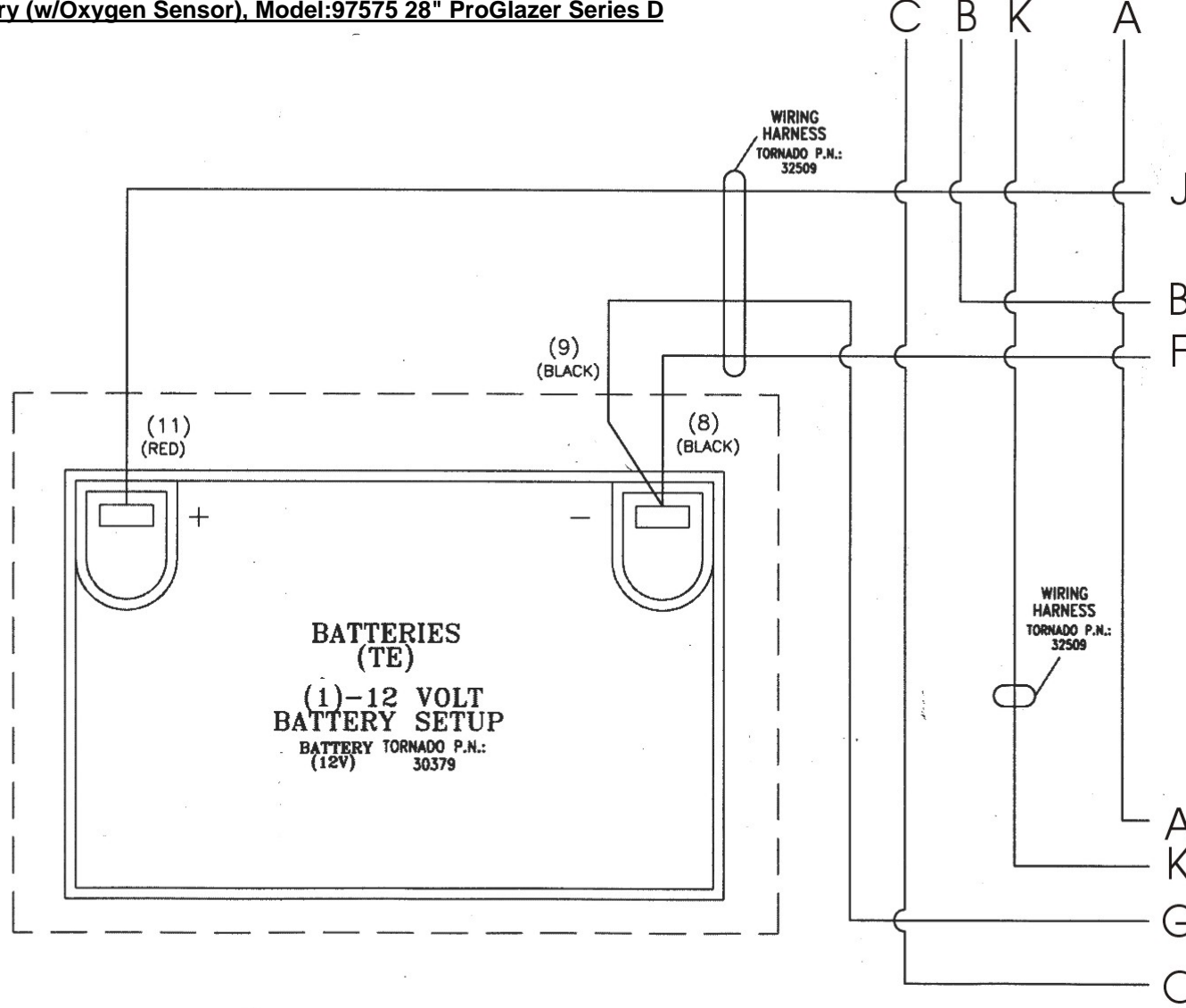

FRONT  
OF  
MACHINE

