

P Series 1600 & 2000 Glazer Schematic

Model :98458 P Series 1600 Glazer (115V)

	Number	Description	Qty Req.
1	X8862+	Flexible Pad Driver Kit	1
2	M1400GS+	14/3 SJTWA, 75', Gray W/Relief (M1200-3)	1
3	SR36+	Strain Relief Washer	1
4	X8218+	Washer, Flat SAE 5/16"	1
5	X8008N+	NUT LOCK 1/2" STEEL CONDUIT APPLETON	1
7	X8012+	Clamp, Collar, Handle	1
8	X8013+	Cord Hook, Plated	1
9	X8207+	Screw, 10-24 x 1/2"	1
10	X8012A+	Handle Tube Clamp Lever Assembly (excludes clamp collar)	1
11	X8016+	Knob, Plastic, Handle Release	1
12	X8022+	In-Line Cord	1
13	X8028+	Oval Cam Washer	1
14	X8037-1+	Motor	1
15	X8097-3+	Pulley M1200-3	1
16	X8216+	5/16-18 x 3/4" Hex Cap Bolt	1
17	X8217+	Washer, Lock 5/16"	1
18	X8219+	3/8" SAE Flat Washer	1
19	X8230+	3/8" Washer	1
20	X8041A+	Motor Cover	1
21	X8050A+	Base Housing	1
22	X8020+	WASHER COUNTERSUNK AXLE	1
23	X8024+	Wheel 5" x 1-1/4"	1
24	X8025+	Wheel Black, 4" x 1-1/4"	1
25	X8027L+	Left Bracket, Brace, Handle, W/Slot	1
26	X8027R+	Right Bracket, Brace, Handle, W/Slot	1
27	X8816+	Axle, 1/2" Dia x 14-1/2"	1
28	X8812+	AXLE 1/2" X 13-1/4" NEW BURNISHER	1
29	X8813+	Pivot Shaft, 1/2" x 10"	1
30	X8030G+	Bumper, 45.75" Blue/Black	1
31	X8101+	Washer, Spring	1
32	X8821+	Screw, 8-32 x 3/4"	1
33	X8210+	SCREW 1/4-20 X 1/2 PHIL FLAT MS ZINC	1
34	X8258A+	Bumper, Blk, 1.13" OD x .75" H	1
35	X8258AS+	#8 x 1" PHPH Type "A"	1
36	X8822+	Spacer, PLastic, Blk, #8 x .25 (2)	1
37	X8091+	Shaft and Plate Weldment	1
38	X8092+	Bearing Space	1
39	X8096+	Main Pulley	1
40	X8098+	Bearing (2)	1
41	X8215+	5/16-18 x 3/4" Hex Cap Bolt	1
42	X8227+	5/16-18 x 1-1/4" Hex Cap Screw	1
43	X8231+	6/16-18 Hex Nut	1
44	X8217+	Washer, Lock 5/16"	1
45	X8219+	3/8" SAE Flat Washer	1
46	X8230+	3/8" Washer	1
47	X8099-7+	39.5 Inch Deep Vee Belt Type B M1200-3	1
48	X8226+	1/4-20 x 1/ 1/4 Hex Head Cap	1
49	X8212+	1/4" Spring Lock Washer	1
50	X8216+	5/16-18 x 3/4" Hex Cap Bolt	1
51	X8218+	Washer, Flat SAE 5/16"	1
52	X8222+	SCREW 1/4-20 X 3/16 SOC SET FLAT POINT W/LOC-TITE	1
53	X8223+	3/8-16 x 3/4" Hex Cap, Grd 5 (4)	1
54	X8230+	3/8" Washer	1
55	X8272+	Screw, 8-32 x 1/2", Truss/PH (2)	1
56	X8811+	Pivot Shaft, 1/2" x 10-1/2"	1
57	X8821+	Screw, 8-32 x 3/4"	1
58	X8912+	Switch Box Cover	1
59	X8914+	Thumb Actuation Release	1
60	X8917+	Handle Trigger	1
61	X8916+	Trigger Tension Spring (2)	1
62	X8915+	Handle Trigger Thumb Actuatin Spring	1
63	X8918+	Handle Roll Pin (2)	1

P Series 1600 & 2000 Glazer Schematic

Model :98458 P Series 1600 Glazer (115V)

	Number	Description	Qty Req.
64	X8941+	1" Handle Grip (2)	1
65	X8207+	Screw, 10-24 x 1/2"	1
66	X8923+	Insulation Sheet	1
67	F5P+	Switch	1
68	X8911+	HANDLE ALL METAL FM .BURNISHR SHIP M8600-3+	1
69	7BG004	7/16" Diameter Grommet	1
70	X8222+	SCREW 1/4-20 X 3/16 SOC SET FLAT POINT W/LOC-TITE	1
71	X8512+	Carbon Brush	1
72	X8034-2+	50AMP, 60 Cycle Rectifier	1
75	X8955+	Start Capacitor 380 UF 125V	1
77	7CY001	WASHER #10 INT TOOTH LOCK SS	1
79	X9298+	Groove Pulley M2000-3	1
80	X8936+	Axle, 1/2" x 13-3/4" M2000 Only	1
81	X8099-5+	40.5 Inch Deep Vee Belt Type B M1600-3	1
82	X8931+	42.5 Inch Deep Vee Belt Type B M2000-3	1

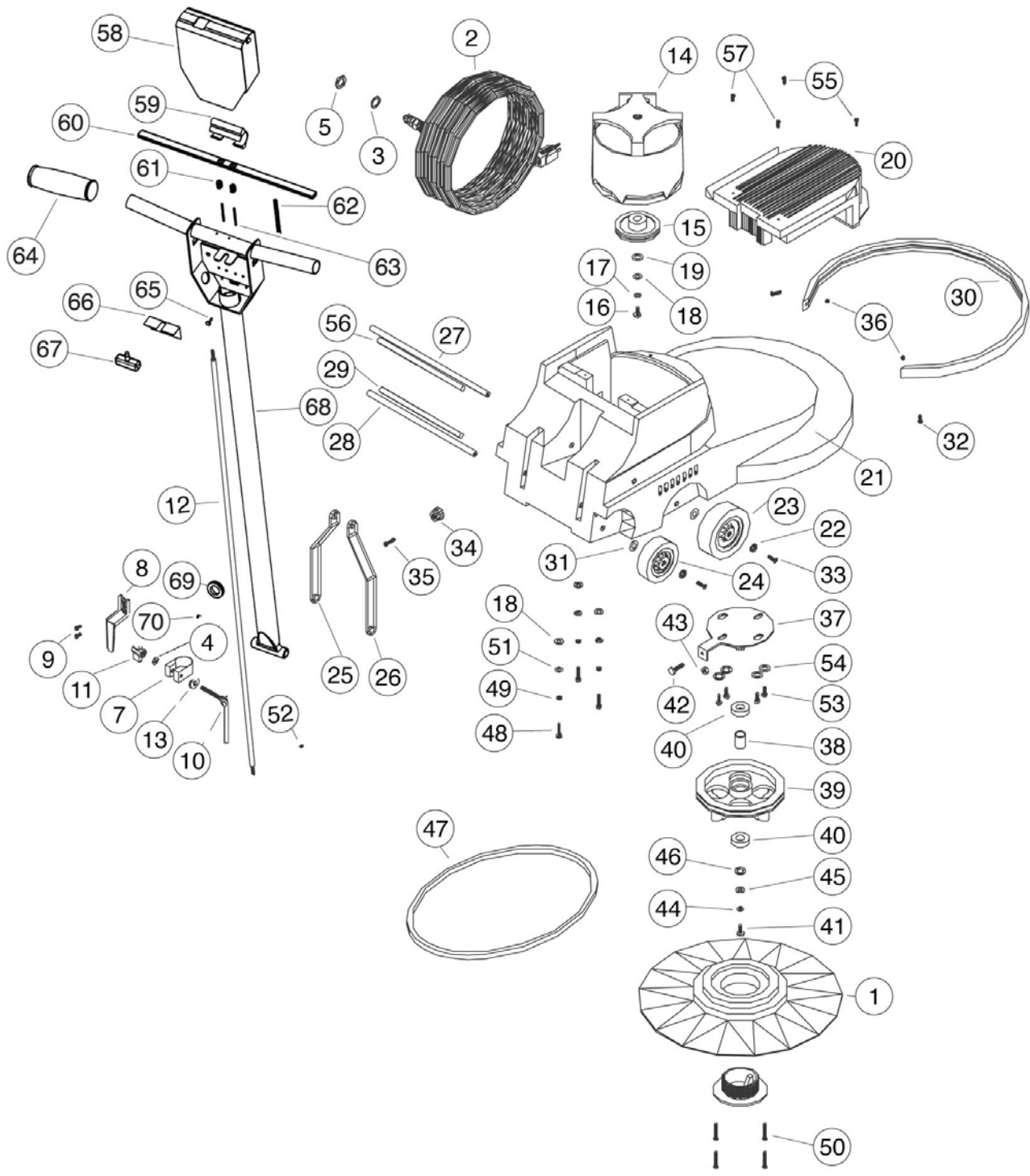

Handle Assembly

Model :98458 P Series 1600 Glazer (115V)

	Number	Description	Qty Req.
1	X8418A+	WARNING LABEL	1
2	X8820+	12 X 2 PHI; FLAT TS-A	1
3	X8805+	LOCK OUT KNOB	1
4	X8819+	1/4 X 1-1/4 PHIL FLAT MACH SCR	1
5	X8818+	1/4 X 1-1/2 PHIL PLAT TC-F	1
6	X8002A+	BOTTOM HANDLE HOUSING	1
7	X8023+	CIRCUIT BREAKER, 15A, W/NUTS	1
7A	X8151C+	3/8" HOLE PLUG	1
8	X8009+	LEAD, 14G, BLK, 4", W/2 F26	1
9	X8009+	LEAD, 14G, BLK, 4", W/2 F26	1
10	F5P+	Switch	1
11	X8284+	8-32 X 3/8" PHPH, TYPE F	1
12	X8026+	TRIGGER PIN	1
13	X8010+	SWITCH SPRING	1
14	X8823+	LOCK-OUT BRUSHING	1
15	X8814+	SPRING, OD .312, WIRE DI .025	1
16	X8804+	LOCK-OUT ROD	1
17	X8817+	#6 SAE FLAT WASHER, BLACK	1
18	X8803+	LOCK-OUT STOP	1
19	X8806+	PLATE, HANDLE SUPPORT	1
20	X8061+	CLIP SWITCH LEVER	1
21	X8003+	HANDLE SWITCH TRIGGER	1
22	X8110A+	COMPRESSION SPRING	1
23	X8005+	CROSS BAR HANDLE	1
24	X8007+	HANDLE GRIP	1
25	X8001A+	TOP HANDLE HOUSING	1
26	X8815+	HANDLE, BACK, M-SERIES, W/LBL	1

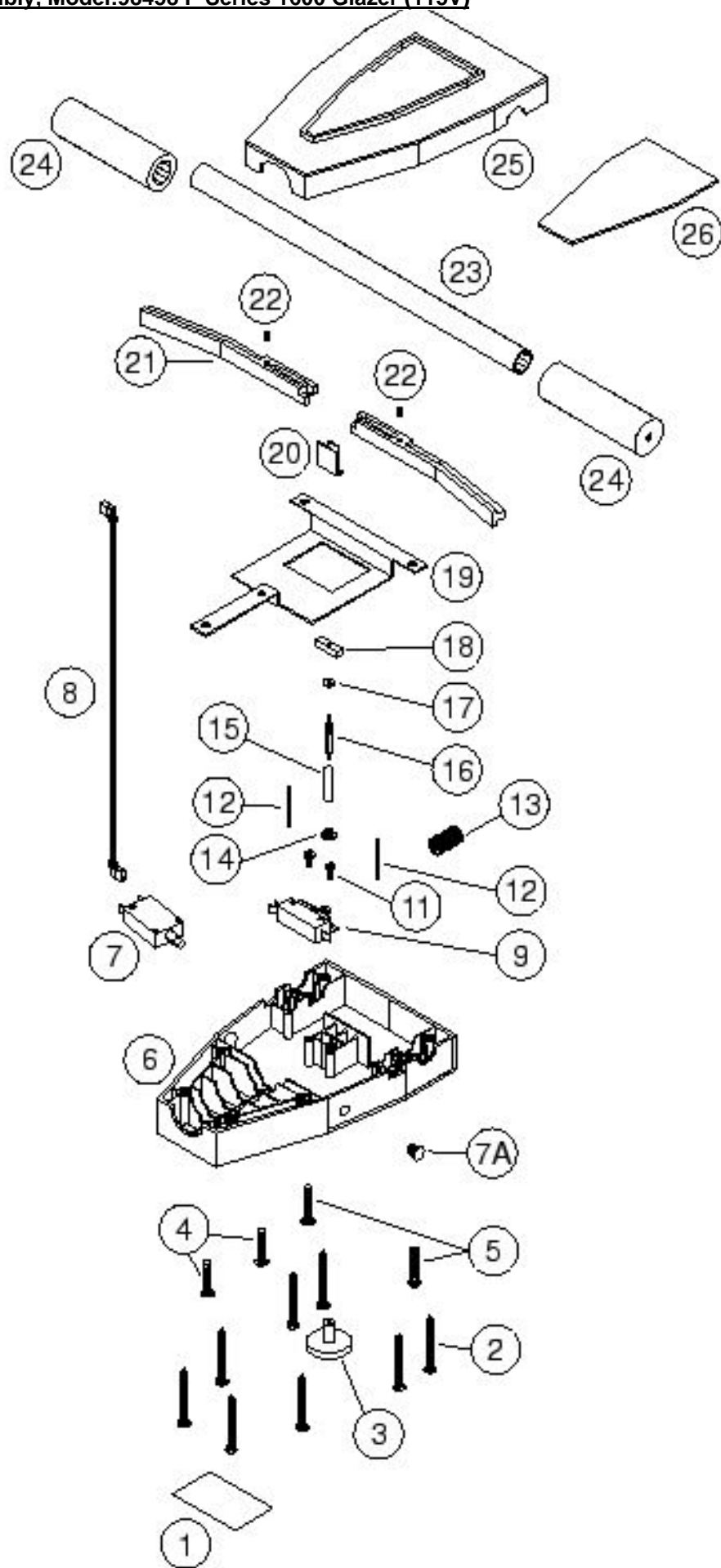

SCHEMATIC USED FOR THE FOLLOWING MACHINES:

M2000-3-DB+	M1600-3-DB+	-	-
M1600-3+	M1600-3-2DB+	-	-
M2000-3+	M1600-3-JL+	-	-
C1600-3+	-	-	-

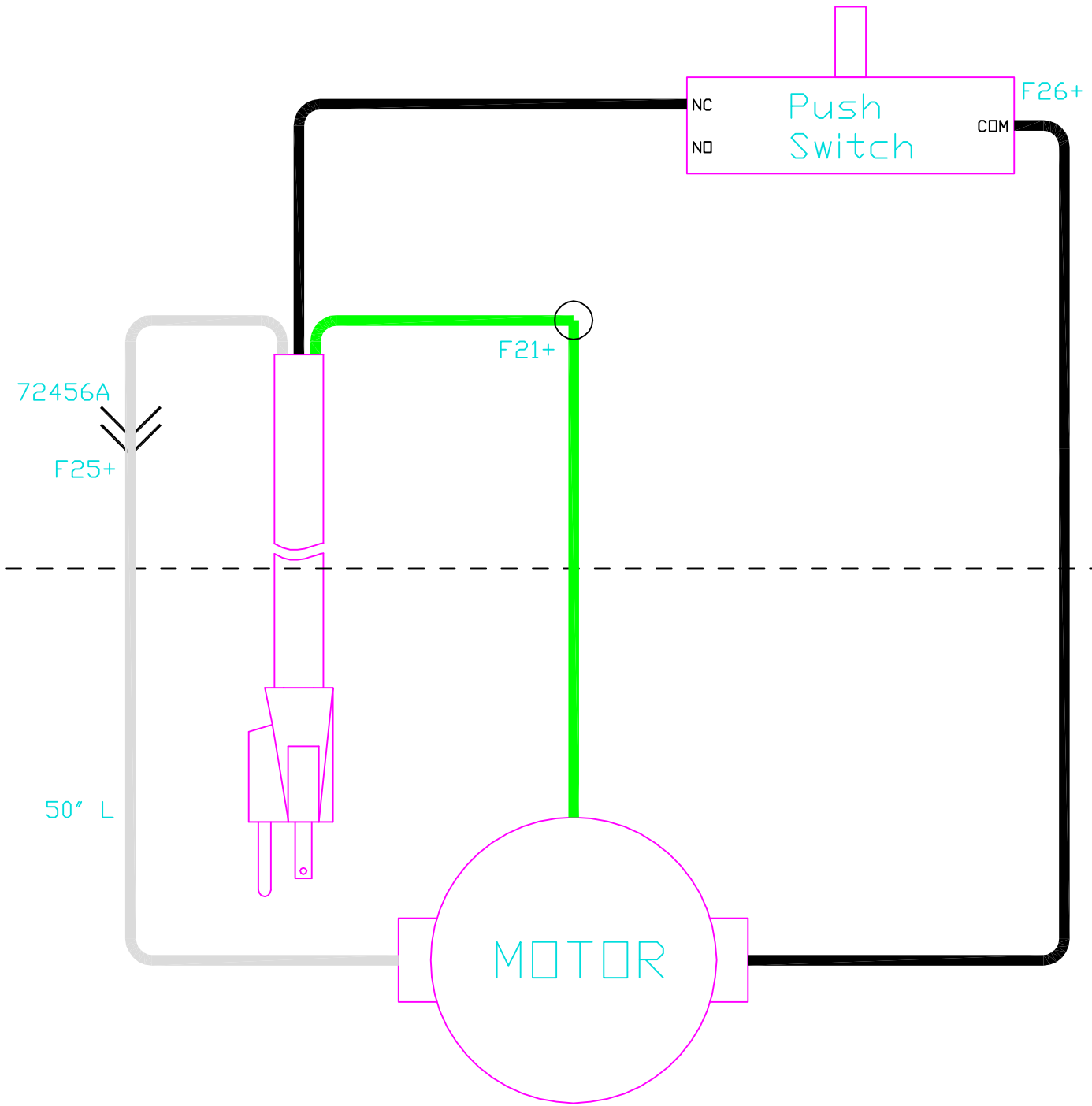

REV	DATE	ECN	DESCRIPTION	BY	Powr-Flite 3101 Wichita Court Fort Worth, TX 76140-1755 <i>COMMERCIAL FLOOR CARE EQUIPMENT</i>		
-	-	-	-	-	MATERIAL	FINISH	SCALE
-	-	-	-	-	DWN	DATE	SHT
-	-	-	-	AR	5/30/07	1 OF 2	
XX ±0.02 IN. RADII XX ±0.02 XXX ±0.01 IN. XXX ±0.01 XXXX ±0.005 IN. COMMON & CONCENTRIC TO 0.002" XXXXX ±0.0005 IN. ± 0°30'				POWR-FLITE CORPORATION CLAIMS PROPRIETARY RIGHTS IN THE MATERIAL DISCLOSED HEREIN. THIS DRAWING IS ISSUED FOR ENGINEERING INFORMATION ONLY. IT MAY NOT BE REPRODUCED, NOR MAY THE INFORMATION HEREIN BE USED FOR MANUFACTURING PURPOSES WITHOUT WRITTEN PERMISSION FROM POWR-FLITE CORP.			
BREAK SHARP EDGES TO .010 MAX.					DESCRIPTION 5 PART NUMBER WPF032		REV -