

## Brush Assembly

Model :93030 30" Clean-Air Carpetkeeper (Wide Area) - Series F

	<b>Number</b>	<b>Description</b>	<b>Qty Req.</b>
1	02011	SCREW-SET SOCK. 1/4-20 X 5/16(BLK.OXID)	2
2	07535	SCREW-TFT (A) R.H. #8-15 X 3/8	4
3	11276	SCREW-PHIL. FLAT HD MACH 1/4-20 X 7/8 (ZP)	2
4	16142	SCREW-PHIL. PAN HD MACH #10-32 X 1/2 (ZP)	4
5	19804	PULLEY BRUSH DRIVE(ALUM) (93030) 6 GRVE.POLY V	1
6	19805	BEARING BLOCK BRUSH-ALUM (93030) 6061-T6 ALUMINUM	2
7	19808	AXLE-BRUSH .500 (CRS) (93030 _93032)	1
8	19809	BEARING BRUSH (VENDOR) (93030)	2
9	19810	SHOE BRUSH MOUNT-16GA.SS (93030)	1
10	19811	28" BRUSH ROLL	1
11	19838	O-RING-NITRILE(BUNA N) (93030)	1
12	19848	GUARD THREAD-22GA SS (93030)	2

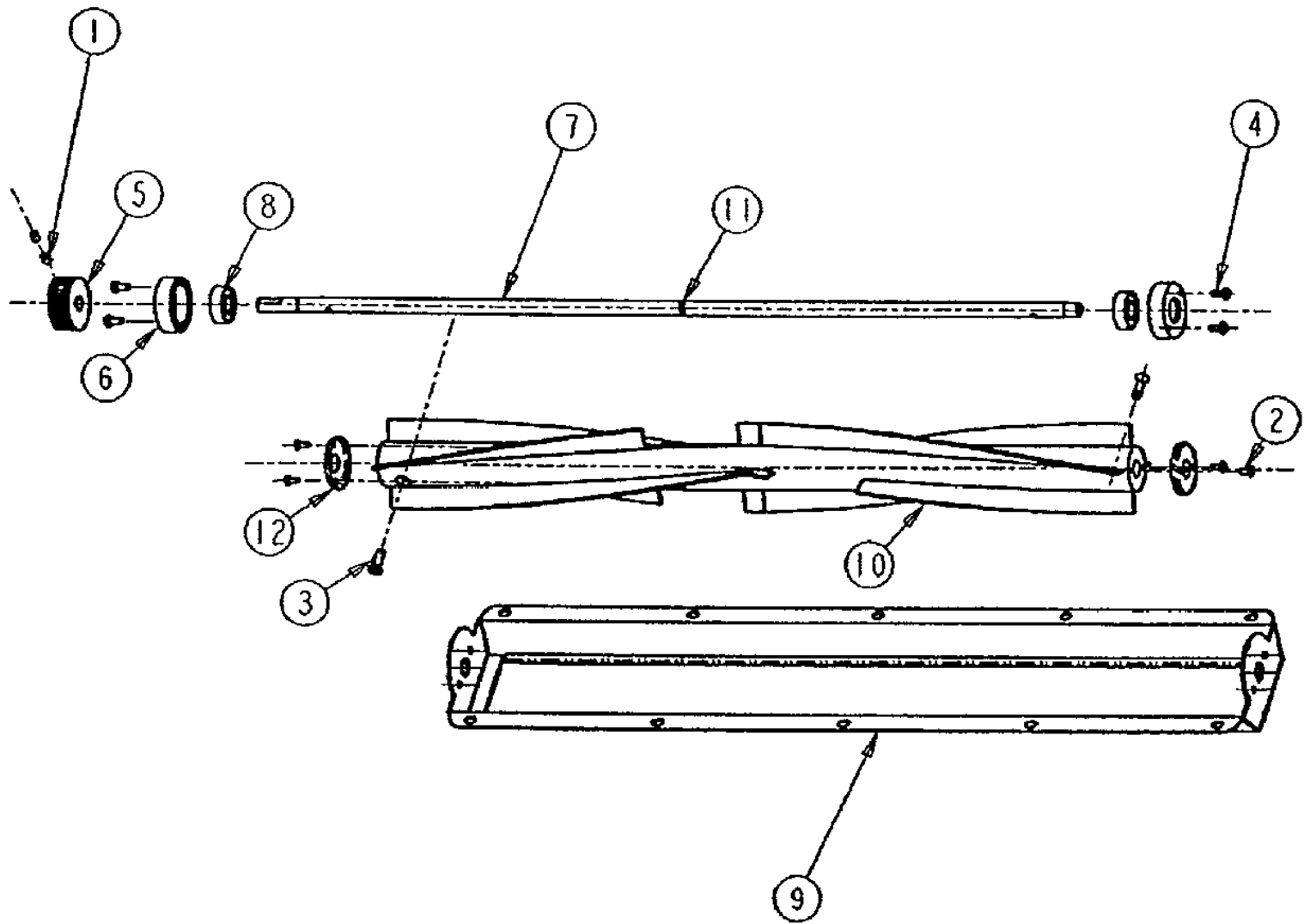

**Full Assembly-Back View**

Model :93030 30" Clean-Air Carpetkeeper (Wide Area) - Series F

	<b>Number</b>	<b>Description</b>	<b>Qty Req.</b>
5	01993	SCREW-PHIL. FLAT HD MACH #10-24 X 5/8 (ZP)	4
17	15475	SCREW-PHIL. FLAT HD MACH #8-32 X 3/8 BLACK ZINC	8
34	19850	SWITCH ON/OFF 10 AMP 250 VAC WAV	1
61	30595	PEDAL-FOOT ADJ.(STEEL) (93030) PAINTED BLACK	1
72	30596	COVER-PEDAL(BLACK NYLON) (93030) MFG.	1

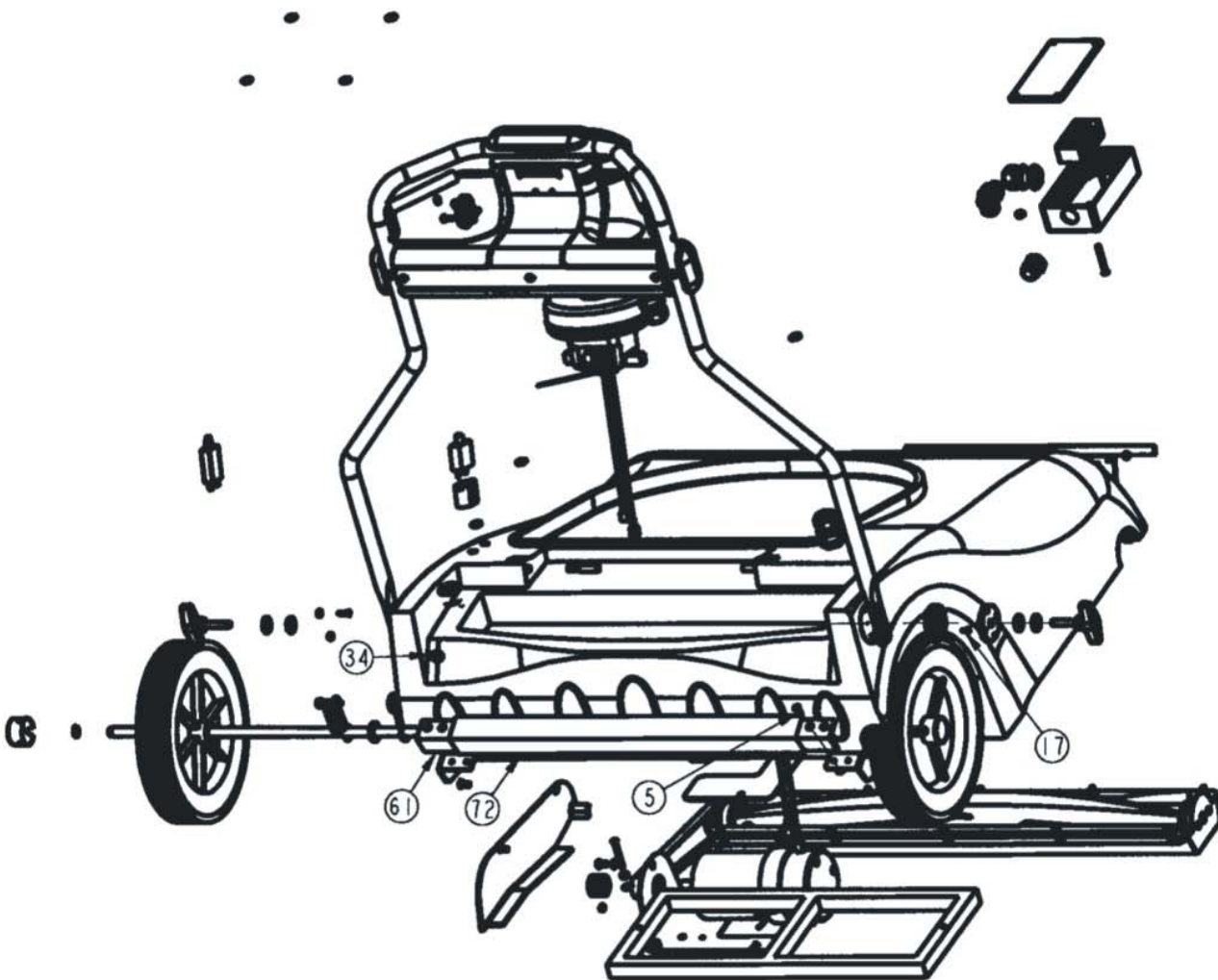
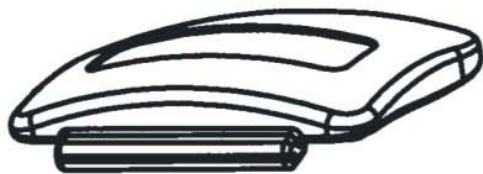

## Full Assembly-Bottom Left & Right View

Model :93030 30" Clean-Air Carpetkeeper (Wide Area) - Series F

	<b>Number</b>	<b>Description</b>	<b>Qty Req.</b>
3	00851	WASHER-PLAIN 1/4	10
14	10894	NUT-HEX.LOCK(P/T) #10-24	4
39	19875	FITTING STRAIGHT(CABLE) (93030)SEALCON-BLK.PLSTC	1
41	19878	CONDUIT CABLE-10LENGTH (93030)-MANUF.DWG.	1
51	30018	SCREW-THUMB W/SHOULDER #10-32 X 1/2 (ZINC)	4
54	30089	GASKET-MOTOR (POLY FOAM) (93030-) .188W/ADHESIVE	2
63	30620	SCREW-PHIL. PAN HD TAPT #10-16 X 3/4 (ZP)	8

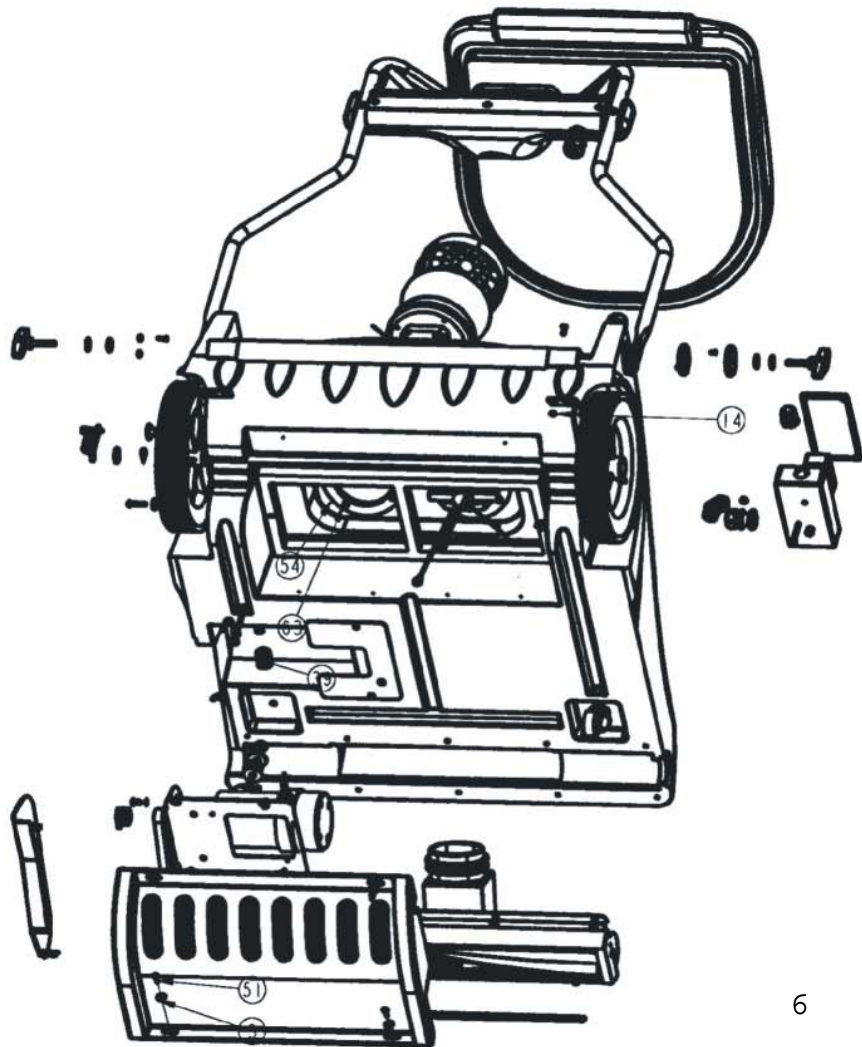
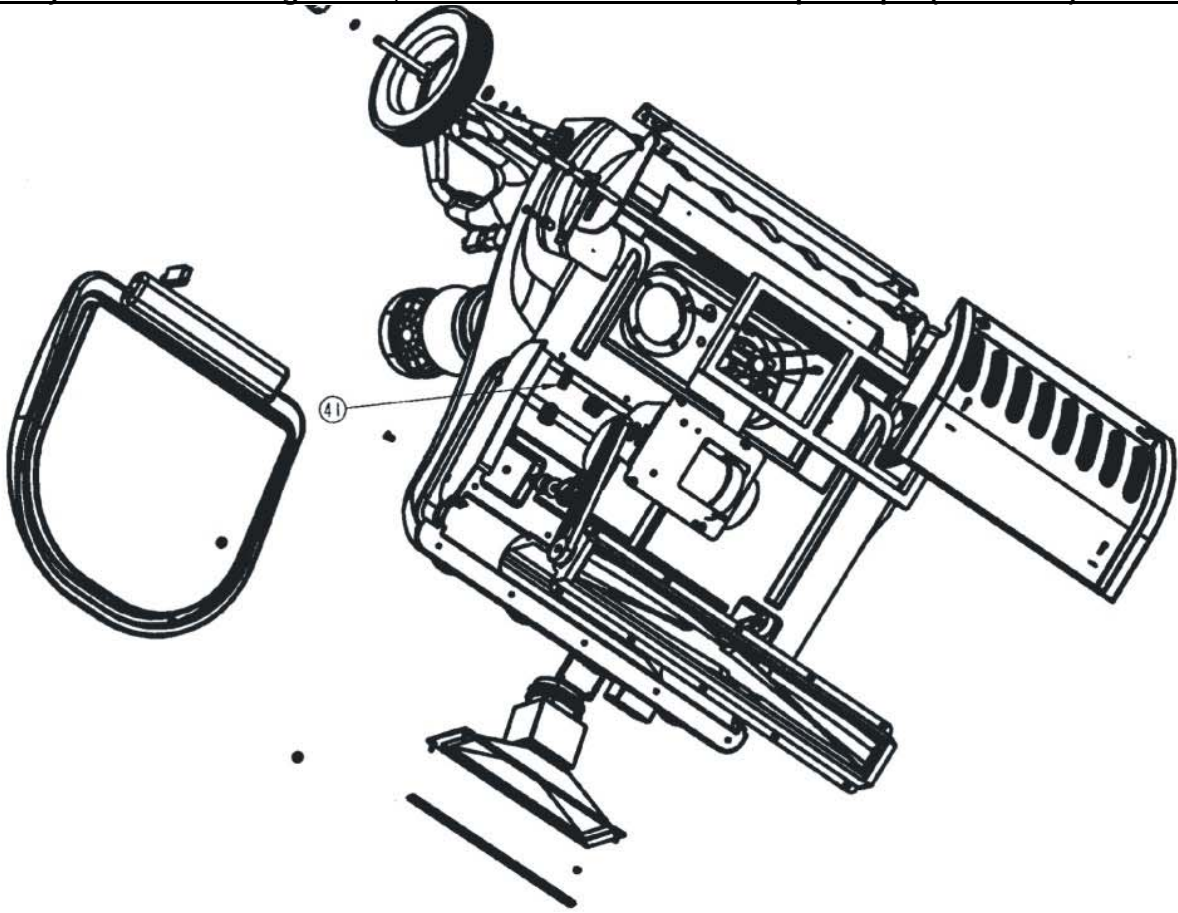

## Full Assembly-Front View

Model :93030 30" Clean-Air Carpetkeeper (Wide Area) - Series F

	Number	Description	Qty Req.
1	00086	SCREW-PHIL. RND HD MACH 1/4-20 X 1/2 (ZP)	16
2	00600	SCREW-SLO. RND HD MACH #8-32 X 3/4 (ZP)	5
3	00851	WASHER-PLAIN 1/4	10
4	01604	NUT-FINISHED HEX #10-32 (ZP)	4
6	02011	SCREW-SET SOCK. 1/4-20 X 5/16(BLK.OXID)	1
7	02568	WASHER-PLAIN 5/16 ID (ZP)	4
8	02956	NUT-HEX.LOCK(KEPS) # 8-32	5
9	03321	WASHER-PLAIN .391 ID (ZP)	4
10	03536	WASHER-LOCK(H/S)3/8	2
11	02958	NUT-HEX.LOCK(KEPS) # 6-32	2
12	07870	WASHER-LOCK(I/T)1/4	2
13	10373	WASHER-PLAIN .500 ID (NEO)	2
15	11385	WASHER-SEALING #10	2
16	15357	SPRING-LATCH RELEASE	2
18	16433	SCREW-PHIL. FLAT HD MACH #10-32 X 1-3/4 (ZP)	4
19	16581	WASHER-PLAIN .563 ID (SS)	4
20	18793	STRAIN RELIEF(LIQ.TITE) .35 DIA. CORD	4
21	19797	WHEEL 10PLSTC.HUB 125LB (93030)9.875OD/1.75WID	2
22	19798	BRACKET SPIR.GRVD-HANDLE (93030)INFILTRATED STEEL	2
23	19802	BELT	1
24	19814	CHASSIS MAIN-ROTO MOLDED (93030) YELLOW	1
25	19818	SPRING 1/2 CURVED(VEND) (93030)	2
26	19819	COVER BELT-ROTO MOLDED W/19854 (93030)	1
27	19822	DUCT INTAKE-ROTO-MOLDED (93030)	1
28	19831	HUB CAP WHEEL WAV (93030)	2
29	19832	LID MOLDED(WAV) (93030) YELLOW	1
30	19834	FILTER VAC.MTR.INTAKE (93030) 5.7	2
31	19835	PULLEY BRUSH DRIVE MOTOR (93030)6 GROOVE POLY-V	1
32	19836	MOUNT BRUSH MOTOR(STEEL) (93030)14GA.SHT BLKPAINT	1
33	19841	ARM WHEEL PIVOT-3/16 X 1 (93030) BAR/BLACK PAINT	2
35	19854	COVER EXHAUST BLK/LLDPE 93030	1
36	19855	FILTER WAV EXHAUST (93030)	1
37	19864	PIN LID HINGE-STEEL.340 (93030)CHROME/ZINC PLATE	2
38	19870	ASSY-BRUSH ROLLER 28 (93030)	1
40	19876	FITTING ELBOW(FOR CABLE) (93030)SEALCON-BLK.PLSTC	1
42	19879	BLOCK TERMINAL (93030)	1
43	19880	BOX ELECTRICAL-PLASTIC (93030)GRAY 5.9 X 3.14	1
44	19975	NUT WING (10-32) ZINC PL (93030) ALT:STEEL GALVAN	2
45	19977	STRAIN RELIEF(PLASTIC) .39-.56 DIA.CABLE-SEALCN	1
46	19984	ASSY-HANDLE(DRAWING) (93030)	1
47	19990	CIRCUIT BREAKER 15 AMP WAV	1
48	19991	BOOT RUBBER-ELEC.CONNECT (93030)	1
49	19999	SCREW-PHIL. RND HD MACH 1/4-20 X 1-1/8 (ZP)	2
50	24185	RECTIFIER-50 AMP (18580/1/3/9/90/2)	1
52	30077	GASKET-SHOE (POLY FOAM) (93030) .64W/ADHESIVE	1
53	30088	FILTER-PRE (93030)	2
55	30461	SLEEVE-PIVOT .5(.25ID) (93030-) FLASH CHROME PL	2
56	30464	SLEEVE-PIVOT(LRG).312ID (93030-) STEEL (ZP)	2
57	30467	SCREW-PHIL. FLAT HD MACH 1/4-20 X 1/2 (ZP)	2
58	30491	ASSY-AXLE, BRUSH LEVEL (93030)	1
59	30507	SNAP RING 1/2 EXTERNAL (93030) .05 THK.	2
60	30558	KNOB-HANDLE ADJ.(BLACK) (93030) 3/8-16 X 1-1/4	2
62	30617	BOLT-SHOULDER SOCKET HD. 5/16 1/4-20 X.75 LONG	2
64	31209	WHEEL W/3/8UNC X 1.63D 1 LG STEM (WIDE AREA)	2
65	31236	CIRCUIT BREAKER 3AMPS 120VOLTS WAV	1
66	31540	MOTOR-VACUUM (120V) SINGLE SPD 50-60HZ	2
67	31544	LEAD-16 GA. X 10 BLACK (93030)	4
68	32419	MOTOR BRUSH DRIVE (115V) (93030) CNTNS CYCLE	1
69	32456	PLATE-MOTOR COVER (PLASTIC) 93030	1
70	80605	GASKET MATL.-NEOPRENE 3/16 X 1/2(CLSD.CELL)	1
71	30466	SPRING-TENSION H.ADJUST (93030-) 302 SS	2
73	19473	CORD-POWER(115V)14/3 75' (MALE PLUG)YELLOW	1

## Full Assembly-Front View

Model :93030 30" Clean-Air Carpetkeeper (Wide Area) - Series F

	<b>Number</b>	<b>Description</b>	<b>Qty Req.</b>
74	19816	CLOTH BAG FOR WIDE ARE VAC	1
75	90701	BAG-PAPER DISPOS-10 PACK (93030) TORNADO IND.	1
76	18706	WIRE TIE-15(BLACK)	4
77	30008	DECAL WIRING (DIAGRAM) (93030) DIAGRAM REFER.	1
78	30017	WIRING HARNESS-MAIN BODY (93030)	1
79	30078	GASKET-HOOD 54 #7 BLACK (93030-) ADHESIVE	1
80	30442	DECAL-REPLACEMENT PARTS(93030-) MYLAR W/ADHESIV	1
81	30618	DECAL-CARPET LEVEL ADJ. (93030)	1
82	15245	TERMINAL-RING #10 X 16/14GA.(INSUL.)	1
83	32526	TUBE-HEAT SHRINK BRUSH MOTOR WIRES	1



Full Assembly-Front View, Model:93030 30" Clean-Air Carpetkeeper (Wide Area) - Series F

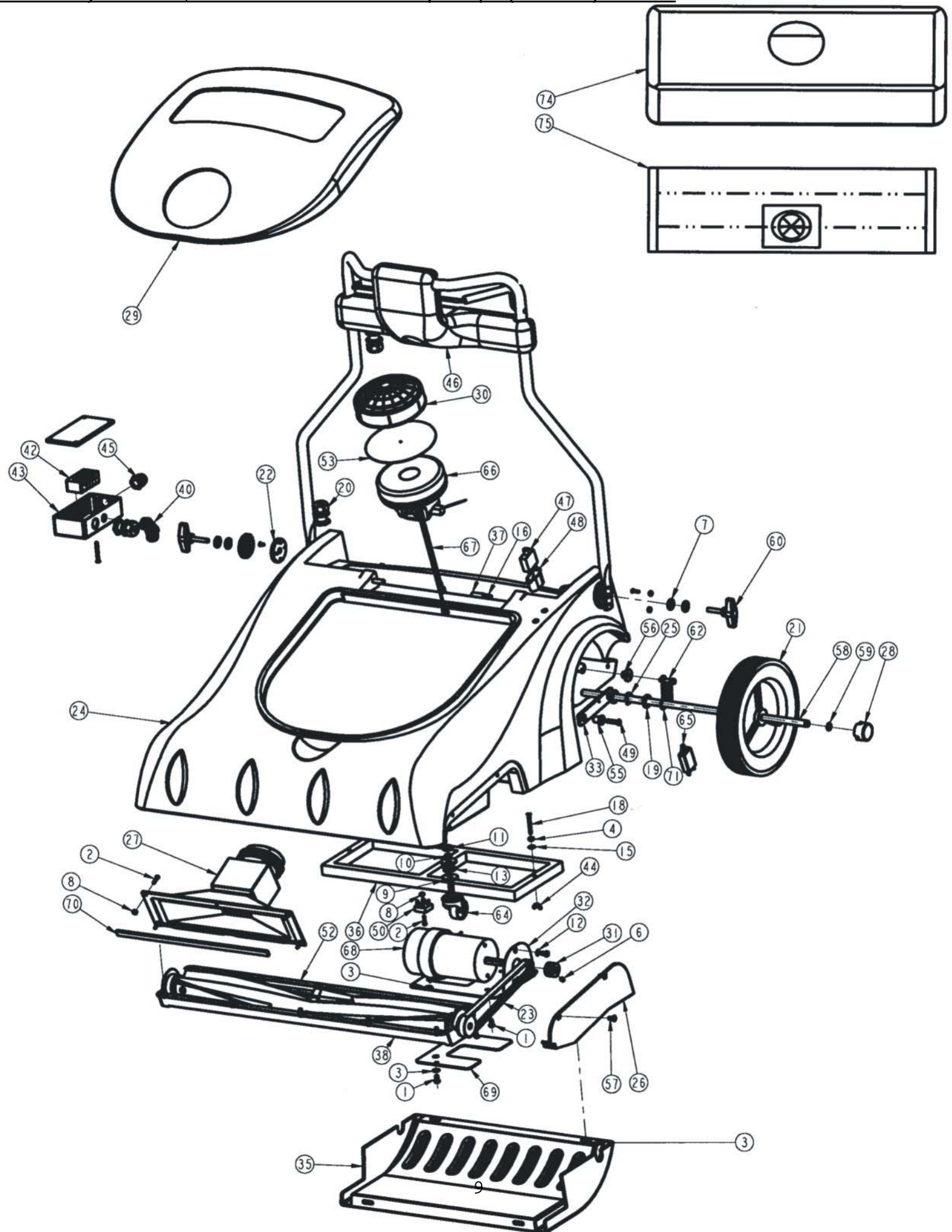

## Handle Assembly

Model :93030 30" Clean-Air Carpetkeeper (Wide Area) - Series F

	Number	Description	Qty Req.
1	03660	SCREW-PHIL. PAN HD MACH #10-24 X 7/16 (ZP)	3
2	05769	SCREW-PHIL. FLAT HD MACH #8-32 X 5/8 (ZP)	4
3	06686	SCREW-PHIL. PAN HD MACH #6-32 X 1.00 (ZP)	2
4	18793	STRAIN RELIEF(LIQ.TITE) .35 DIA. CORD	1
5	19357	SWITCH-PUSH BT(DPST)WAV 20A,125-250VAC,1HP/CHERY	1
6	19798	BRACKET SPIR.GRVD-HANDLE (93030)INFILTRATED STEEL	2
7	19829	HANDLE MAIN-STEEL TUBE (93030) BLACK PAINT	1
8	19849	TRIGGER BRUSH SWITCH.25 (93030).25 CRS-BLK.PAINT	1
9	19869	COVER CONTRL PANEL(STL) (93030)	1
10	19971	GRIP FOAM TRIGGER(BLACK) (93030)EXTRUDED FOAM	2
11	19999	SCREW-PHIL. RND HD MACH 1/4-20 X 1-1/8 (ZP)	3
12	30074	NUT-HEX.LOCK STEEL # 8-32 (ZINC PLATE)	4
13	30874	CONTROL PANEL-ROTO(93032) COLOR:GREY	1
	19813	CONTROL PANEL-ROTOMOLDED (93030) MOLD W/19854	1
14	19996	WIRING HARNESS-TRIGGER (93030) UPPR.CNTRL.PANEL	1

