

Handle Assembly

Model :98220 Model PS8220 Spotter - Series G

	Number	Description	Qty Req.
1	01713	WASHER-LOCK(H/S)#10	4
2	19617	SCREW-PHIL. PAN HD MACH #10-24 X 1.00 (SS)	4
3	31471	BRACKET-PUMP(MOUNT) (SPOTTER)	1
4	31214	USE #31215 HANDLE TRANSPORT	1

DO NOT OVER-TIGHTEN
SCREWS WHEN ATTACHING
HANDLE TO MAIN BODY

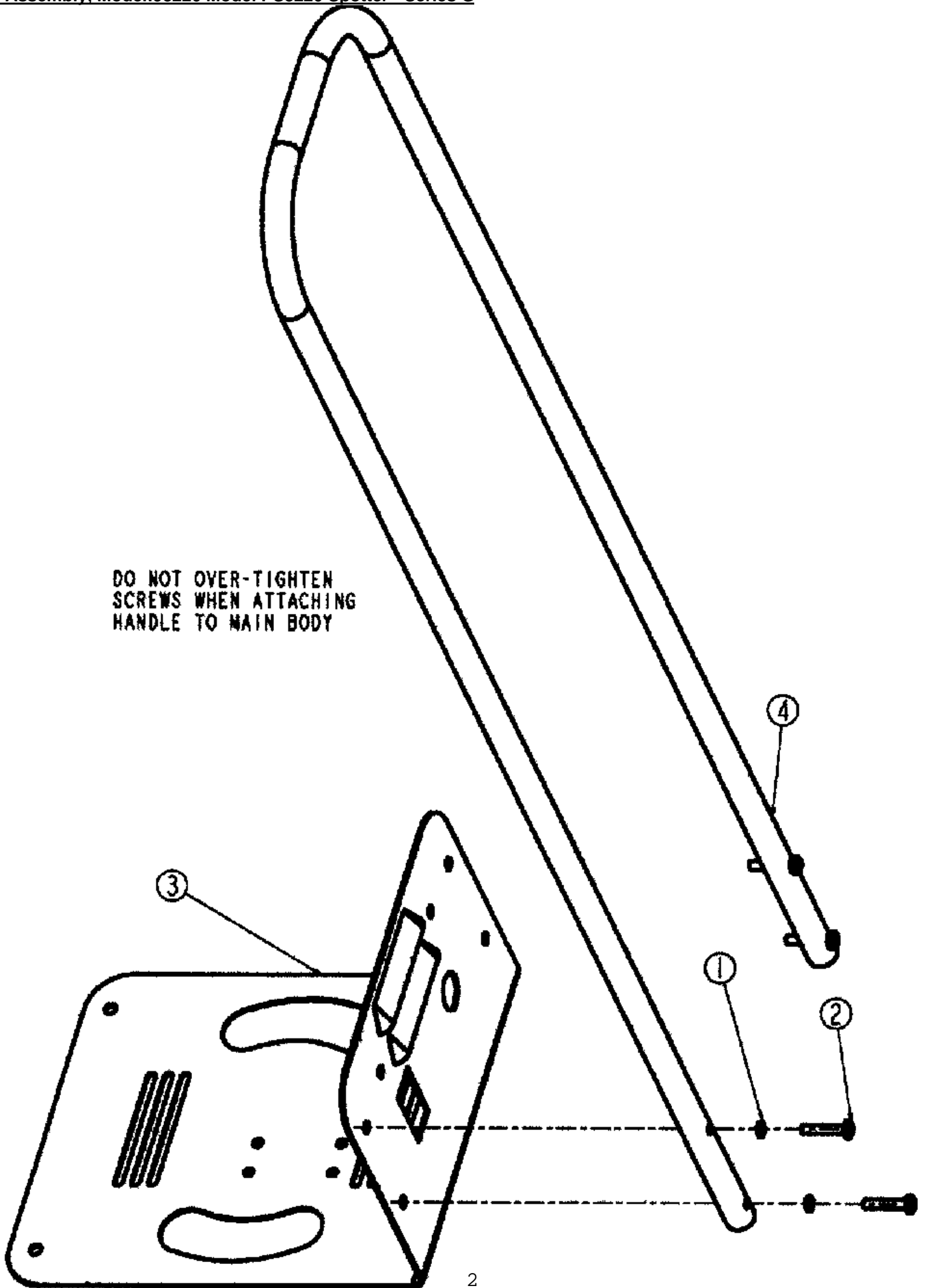

Main Assembly

Model :98220 Model PS8220 Spotter - Series G

	Number	Description	Qty Req.
1	00600	SCREW-SLO. RND HD MACH #8-32 X 3/4 (ZP)	2
2	01713	WASHER-LOCK(H/S)#10	1
3	02956	NUT-HEX.LOCK(KEPS) # 8-32	2
4	02995	SCREW-PHIL. PAN HD MACH #8-32 X 3/8 (ZP)	4
5	07741	WASHER-SEALING 1/4	2
6	10892	NUT-HEX.LOCK(KEPS) #10-24	6
7	12957	WASHER-PLAIN 1/2 ID (ZP)	1
8	14881	FITTING-BRASS NIPPLE 1/4FPT X 1/4Q.C.	1
9	15065	CLAMP-HOSE(CRIMP TYPE) .433-.512(2-EAR)	4
10	15075	FITTING-BRASS ELBOW(45D) 1/4FPT X 1/4MPT	2
11	15223	FITTING-BRASS ELBOW 1/4MPT X 3/8 I.D. HB	1
12	14800	MOTOR-VACUUM BYPASS SS 2-STAGE 115V/50-60HZ	1
	17425	MOTOR-VACUUM BYPASS P/D 2-STAGE 230V/50-60HZ ACC	1
13	17848	SCREW-PHIL. TRUSS HD #10-24 X 1/2 (SS)	11
14	17850	WASHER-PLAIN #10 ID (SS)	8
15	19191	WASHER-PLAIN .328 ID (SS)	4
16	19255	SCREW-SCKT. FLAT HD MACH #8-32 X 1/2 (BLK OXIDE)	2
17	19490	TANK-SOLUTION(SPOTTER) ORD W/19491,19510,19937	1
	30896	TANK-SOLUTION (SPOTTER)GREY	1
18	19491	TANK-RECOVERY(SPOTTER) ORD W/ 19490,19510,19937	1
	30897	TANK-RECOVERY (SPOTTER)GREY	1
19	19504	LATCH-DRAW W/KEEPER (SPOTTER)	2
20	19505	WHEEL- 6 DIA. X 1-1/4 (BLACK W/BLACK HUB)	2
21	19506	SPACER-5/16 DIA.	2
22	19513	NUT-HEX LOCK (NYL.INS.) 5/16-18 (ZP)	2
23	19516	ASSEMBLY-VACUUM STACK/ FLOAT CAGE(SPOTTER)	1
24	19517	SCREEN-VAC.MOTOR INTAKE	1
25	19520	FILTER-VAC. MOTOR INTAKE (FOAM)	1
26	19522	PIPE-NIPPLE (SCH.40) 1/4MPT X 4 BRASS	1
27	19523	FITTING-BRASS ADAPTOR 1/4FPT X 1/4HB	2
28	19524	FITTING-NYLON ELBOW 1/8MPT X 1/4HB	2
29	19525	FILTER-SOL.SCREEN	1
30	19528	HOSE-SOLUTION(SCREEN) (SPOTTER)	1
31	19530	WASHER-LOCK(I/T)# 8	4
32	19532	SCREW-PHIL. PAN HD MACH 5/16-18 X 3 (SS)	2
33	19533	LABEL-WARNING!TO REDUCE THE RISK OF ELECTRIC...	1
34	19565	SCREW-TFT(B)PAN HEAD #10-16 X 1/2	4
35	19610	GASKET-SOLUTION TANK (PROSPOT)	1
36	19611	LABEL-VACUUM ONLY-OFF- VACUUM/SPRAYSWITCH(PS)	1
37	19616	WASHER-PLAIN .563 ID (SS)	3
38	19937	SHROUD-VAC MOTR SPOTTER ORD W/19490 19491 19510	1
39	30019	WASHER-LOCK(E/T #10) SS 18-8 SS (SAE 301-305)	6
40	30456	GASKET-MOTOR(BOTTOM) PVC (98220,225-)SS ADHESIVE	1
41	30457	GASKET-MOTOR(TOP)VOLARA (98220,225-)SS ADHESIVE	1
42	30472	SWITCH-ROCKER DPDT(15A) (98220 225-)125VAC 3/4HP	1
43	30475	BRACKET-MOTOR VAC(MOUNT) (98220 225) BLACK PAINT	2
44	30678	SCREW-PHIL. PAN HD MACH #10-24 X 3/8 (SS)	10
45	30814	DECAL-TORNADO W/ LOGO 1.75 WIDE X 7.25 LG. BLK	1
46	19499	ASSY-POWER CORD (115V) (SPOTTER)	1
	31059	POWER CORD 25 FT(230V) INTER.HARM.-CEE 7/7 PLUG	1
47	31067	POWER LINE FILTER (RFI) 6A,120/250V,50-60HZ	1
48	31471	BRACKET-PUMP(MOUNT) (SPOTTER)	1
49	31479	SOLENOID PUMP - 120V (PS CARPET SPOTTER)	1
	31480	SOLENOID PUMP - 230V (PS CARPET SPOTTER)	1
50	31490	BRACKET-PUMP MOUNTING (SPOTTER) RUBBER	2
51	19527	HOSE-SOLUTION(PUMP) (SPOTTER)	2

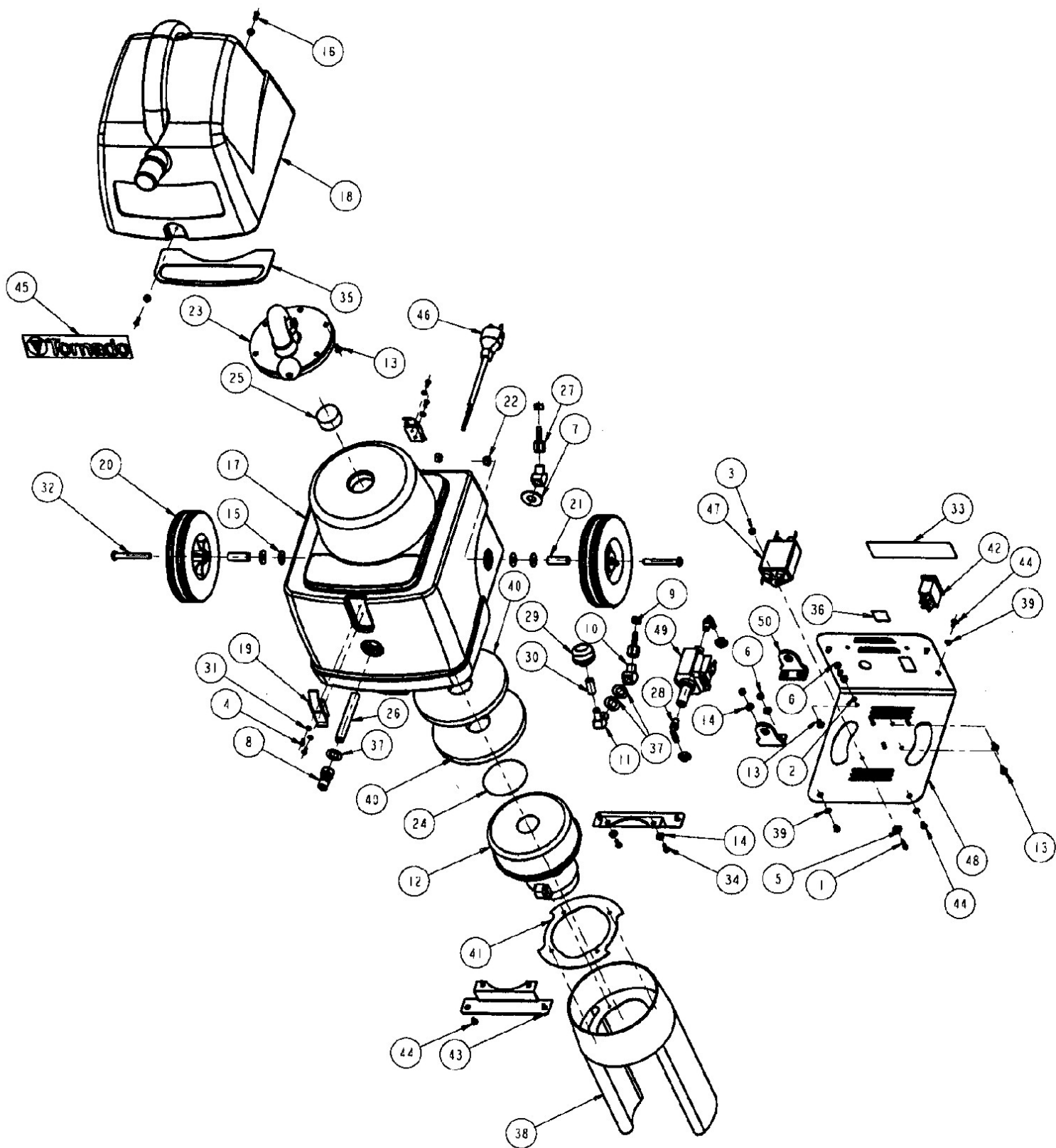

Vac/Pressure Hose Ass'y

Model :98220 Model PS8220 Spotter - Series G

	Number	Description	Qty Req.
1	30735	HOSE-STEEL SUPPORTED BLK 1 X 96 W/CUFFS	1
	19529	HOSE-POLYETHYLENE (BLK)1" X 96" W/CUFFS	1
2	30801	SOLUTION HOSE ASS'Y (SPOTTER)	1
	19369	LEAD-18 GA. X 16 GREEN	1
	19535	ASSEMBLY-VAC./PRESS.HOSE8'(SPOTTER-HIGH PERF.)	1
3	30857	TOOL-UTILITY (STANDARD) 3-1/2	1
4	18706	WIRE TIE-15(BLACK)	4

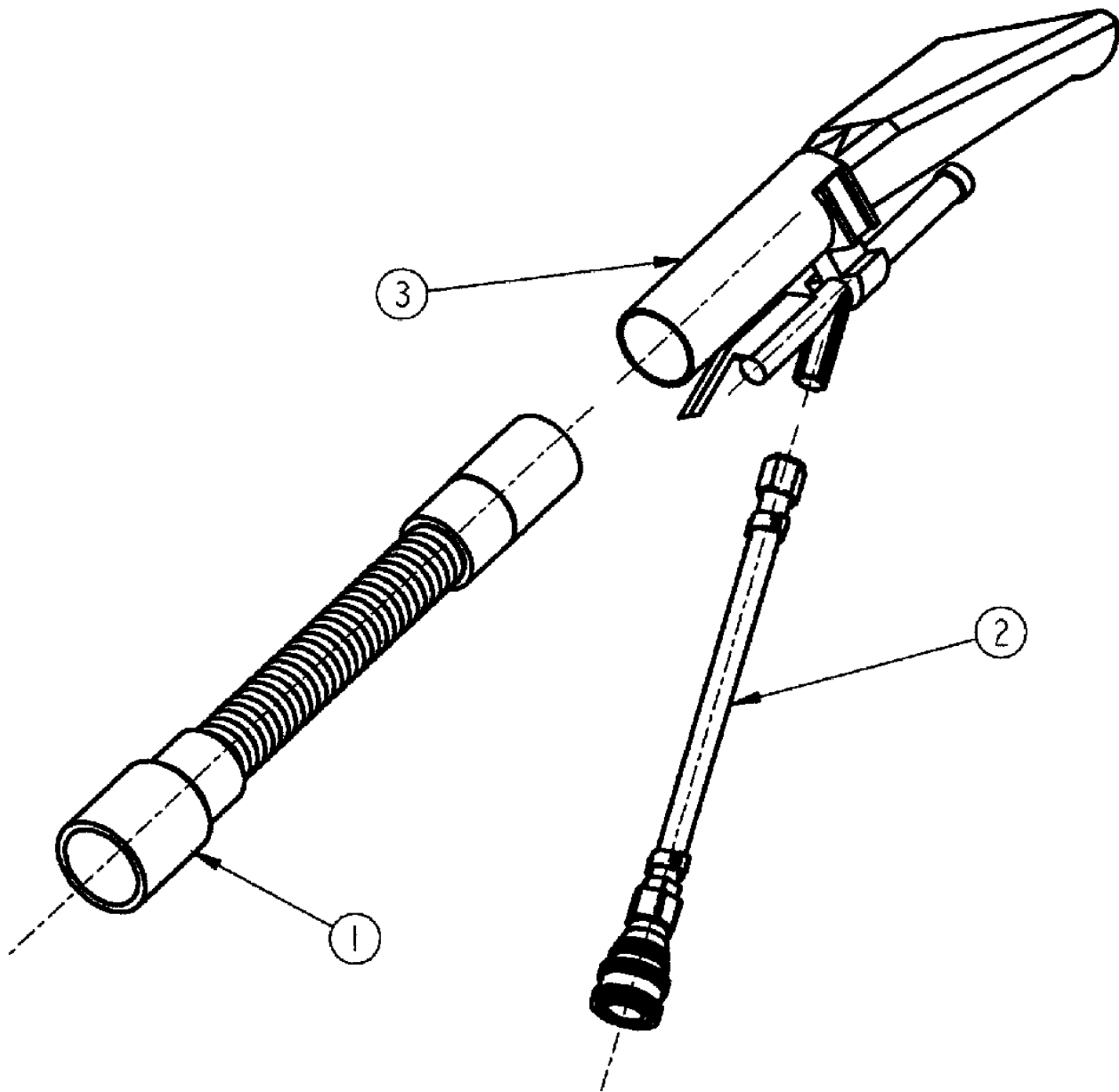

Wiring Diagram

Model :98220 Model PS8220 Spotter - Series G

	Number	Description	Qty Req.
1	01713	WASHER-LOCK(H/S)#10	1
2	03261	SCREW-TCT(F)PAN HEAD #10-32 X 3/8	1
3	06824	TERMINAL-CLOSD.END CRIMP (FUL. INSUL) SPLY LOOSE	1
4	18793	STRAIN RELIEF(LIQ.TITE) .35 DIA. CORD	1
5	19466	LEAD-14 GA. X 3 BLACK	2
6	19499	ASSY-POWER CORD (115V) (SPOTTER)	1
7	19500	ASSEMBLY-POWER CORD 230V (SPOTTER)	1
8	19503	TERMINAL-Q.D.FEMALE 1/4 X 22/18GA.(FUL.INS)	1
9	19536	LEAD-18 GA. X 12 GREEN	1
10	19537	LEAD-16 GA. X 12 BLACK	1
11	19538	LEAD-16 GA. X 12 WHITE	1

