

SCHEMATIC USED FOR THE FOLLOWING MACHINES:

PDF5+	-	-	-
PDF5DX+	-	-	-
PDF5C+	-	-	-
-	-	-	-

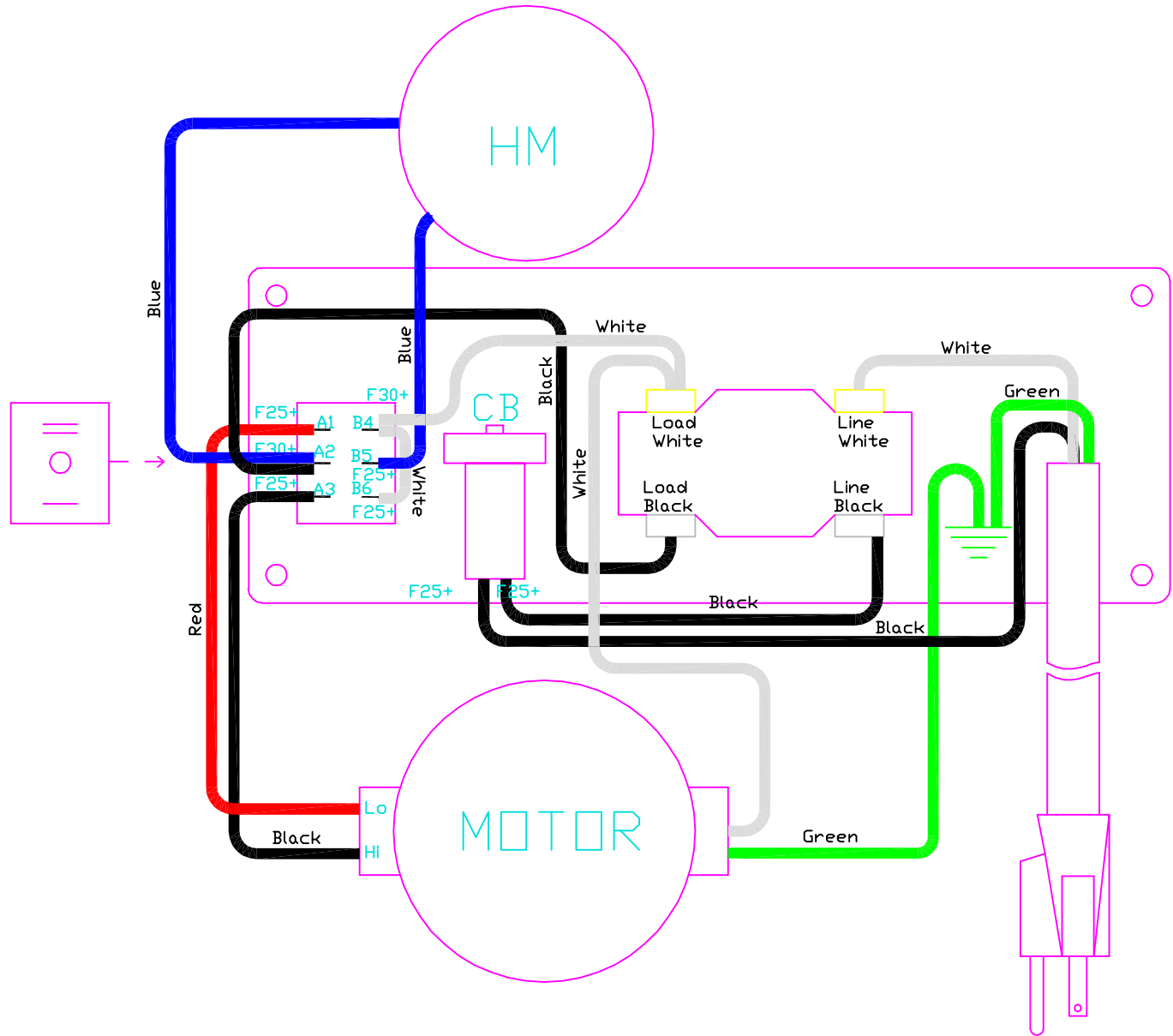

REV	DATE	ECN	DESCRIPTION	BY	<i>Powr-Flite</i> COMMERCIAL FLOOR CARE EQUIPMENT		3101 Wichita Court Fort Worth, TX 76140-1755			
-	-	-	-	-	MATERIAL	-	FINISH	-	SCALE	-
-	-	-	-	-	DWN	AR	DATE	5/11/07	SHT	-
XX ±0.02 IN. RADI XX ±0.02 XXX ±0.01 IN. XXX ±0.01 XXXX ±0.005 IN. COMMON & CONCENTRIC TO 0.002" XXXX ±0.0005 IN. ± 0°30'					POWR-FLITE CORPORATION CLAIMS PROPRIETARY RIGHTS IN THE MATERIAL DISCLOSED HEREIN. THIS DRAWING IS ISSUED FOR ENGINEERING INFORMATION ONLY. IT MAY NOT BE REPRODUCED, NOR MAY THE INFORMATION HEREIN BE USED FOR MANUFACTURING PURPOSES WITHOUT WRITTEN PERMISSION FROM POWR-FLITE CORP.					
BREAK SHARP EDGES TO .010 MAX.					DESCRIPTION		WPF009		REV	
					A PART NUMBER		WIRING DIAGRAM		-	

Windshear Sidedraft

Model :98782 Windshear Sidedraft (115V)

	Number	Description	Qty Req.
1	X9180+	HOUSING F5 AXIAL FAN BLACK	1
2	PD3C+	FOOT BLACK RUBBER N/S DRYER HANDLE SHORT	1
3	X9098+	SCREW A POINT PH PAN HD #10X1	1
4	X8260+	NUT 8-32 LOCK W/NYLON INSERT	1
5	72719A	BRACKET AXIAL FAN MOTOR F5	1
6	X9183+	GRILL F5, AXIAL FAN	1
7	X9189+	Label, Round (at Grill)	1
8	X9195+	CASTER RECEIVER F5, AXIAL FAN	1
9	P50+	Wheel and Socket	1
10	72020A	SCREW SELF-TAP PHMS ZINC #12 X 1"	1
11	X9181+	MOTOR 115VAC .25HP 4 POLE F5, AXIAL FAN W/THRUBOLTS	1
12	X8209+	1/4-20 X 1/2" HEX CAP SCREW	1
13	X9065+	SCREW HEX SOCKET CAP 1/4-20X1 FACTORY BLACK	1
14	X8990N+	HANDLE/WHEEL ASSEMBLY NARROW AXIAL FAN (2 PER BOX)	1
15	X8848+	JACKNUT 1/4-20 STEEL #8LJN	1
16	X9190+	Label, Product at Top, Axial Fan	1
17	72721A	SWITCH PANEL F5 AXIAL FAN	1
18	X9048+	SWITCH ROCKER SPOTTER	1
19	X9186+	CIRCUIT BREAKER 12A F5 AXIAL FAN	1
20	X9188+	SCREW 6-32 X 3/8" BLACK MS	1
21	X8926+	20' HD 3 WIRE CORD 16/3 SJTW 115 VOLT (NEW DRYER)	1
22	PD8+	STRAIN RELIEF 1/2" NPT SCE	1
23	X8008N+	NUT LOCK 1/2" STEEL CONDUIT APPLETON	1
24	X9187+	GFCI OUTLET FEMALE PLUG F5 AXIAL FAN	1
25	X9182P+	FAN BLADE ASSEMBLY PLASTIC F5 3 BLADE	1
26	F631+	Round Belt	1
27	72470A	HEAT SHRINK BLK 1/2" X 200' FLEXIBLE POLYOLEFIN	1
28	PD3B+	DRYER FOOT N/S DRYER TALL	1

Windshear Sidedraft, Model:98782 Windshear Sidedraft (115V)

