

Handle Assembly

Model :97562 P Series 17" Floor Machine With Pad Holders (115V)

	Number	Description	Qty Req.
1	X8418A+	WARNING LABEL	1
2	X8820+	12 X 2 PHI; FLAT TS-A	1
3	X8805+	LOCK OUT KNOB	1
4	X8819+	1/4 X 1-1/4 PHIL FLAT MACH SCR	1
5	X8818+	1/4 X 1-1/2 PHIL PLAT TC-F	1
6	X8002A+	BOTTOM HANDLE HOUSING	1
7	X8023+	CIRCUIT BREAKER, 15A, W/NUTS	1
7A	X8151C+	3/8" HOLE PLUG	1
8	X8009+	LEAD, 14G, BLK, 4", W/2 F26	1
9	X8006+	SWITCH BRACKET	1
10	F5P+	Switch	1
11	X8284+	8-32 X 3/8" PHPH, TYPE F	1
12	X8026+	TRIGGER PIN	1
13	X8010+	SWITCH SPRING	1
14	X8823+	LOCK-OUT BRUSHING	1
15	X8814+	SPRING, OD .312, WIRE DI .025	1
16	X8804+	LOCK-OUT ROD	1
17	X8817+	#6 SAE FLAT WASHER, BLACK	1
18	X8803+	LOCK-OUT STOP	1
19	X8806+	PLATE, HANDLE SUPPORT	1
20	X8061+	CLIP SWITCH LEVER	1
21	X8003+	HANDLE SWITCH TRIGGER	1
22	X8110A+	COMPRESSION SPRING	1
23	X8005+	CROSS BAR HANDLE	1
24	X8007+	HANDLE GRIP	1
25	X8001A+	TOP HANDLE HOUSING	1
26	X8815+	HANDLE, BACK, M-SERIES, W/LBL	1

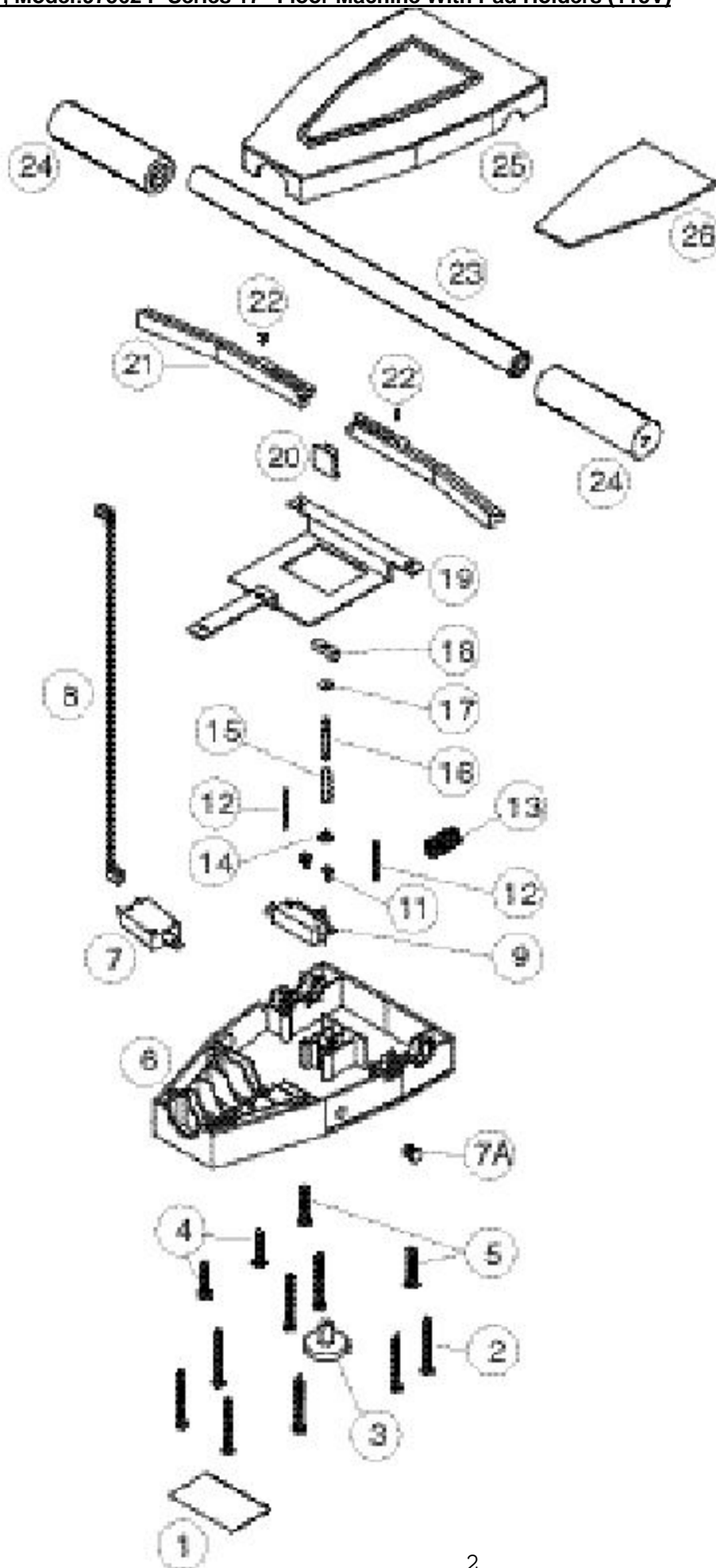

SCHEMATIC USED FOR THE FOLLOWING MACHINES:

C171HD+	-	-	-
C201HD+	-	-	-
M171HD-3+	-	-	-
M201HD-3+	-	-	-

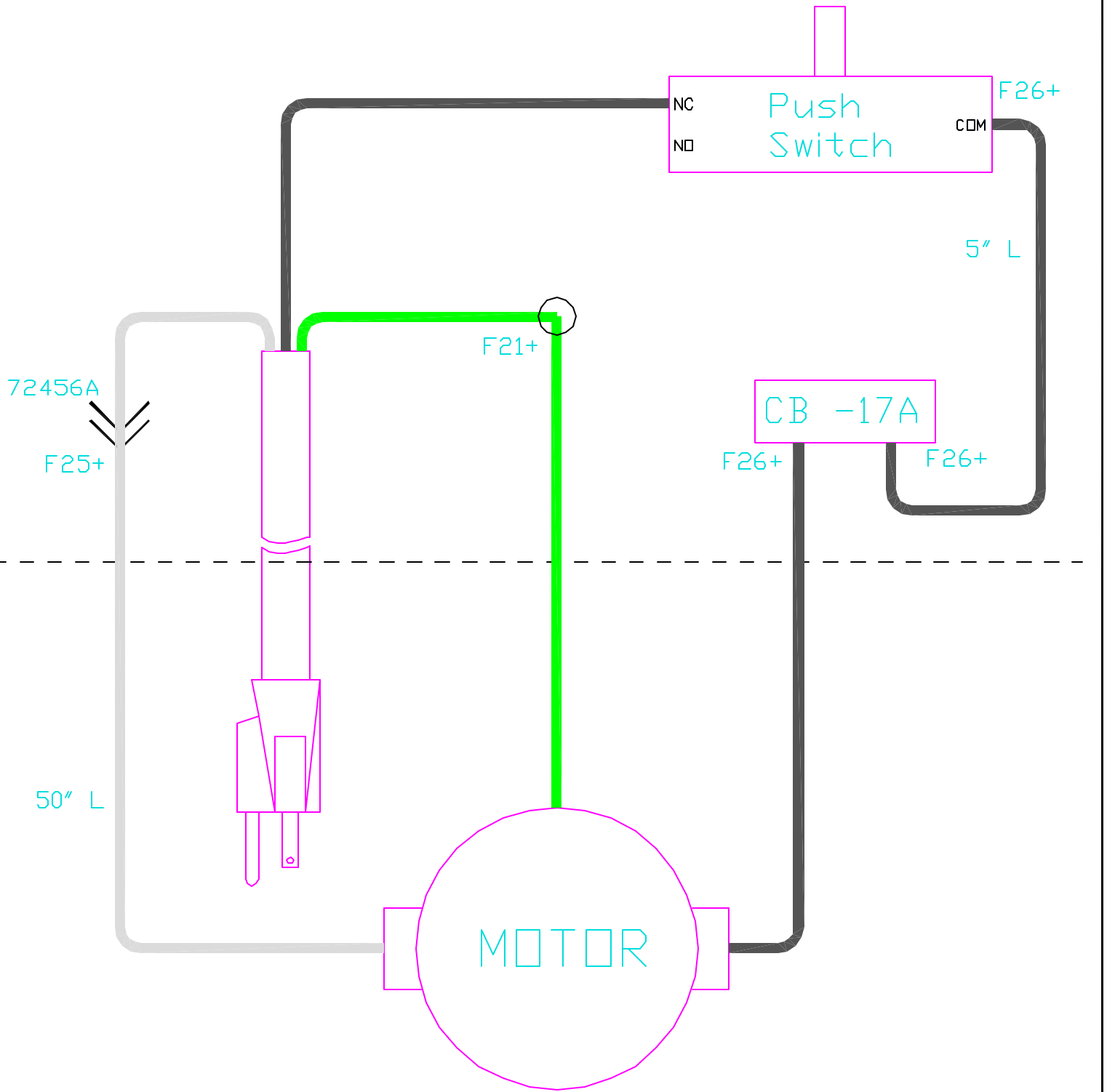

REV	DATE	ECN	DESCRIPTION	BY	Powr-Flite 3101 Wichita Court Fort Worth, TX 76140-1755 COMMERCIAL FLOOR CARE EQUIPMENT			
-	-	-	-	-	MATERIAL	FINISH	SCALE	
-	-	-	-	-	DWN	DATE	BHT	
-	-	-	-	-	CSD	2/20/07	1 OF 2	
XX .002 IN. RADII, XX ±0.02 XXX .01 IN. XXX ±0.01 XXXX .0005 IN. COMMON & CONCENTRIC TO DATE XXXXX .0005 IN. ± 0-20 BREAK SHARP EDGES TO .010 MAX.				POWR-FLITE CORPORATION CLAIMS PROPRIETARY RIGHTS IN THE MATERIAL DISCLOSED HEREIN. THIS DRAWING IS ISSUED FOR ENGINEERING INFORMATION ONLY. IT MAY NOT BE REPRODUCED, NOR MAY THE INFORMATION HEREIN BE USED FOR MANUFACTURING PURPOSES WITHOUT WRITTEN PERMISSION FROM POWR-FLITE CORP.				
DESCRIPTION					WIRING SCHEMATIC WPF026		REV	-
A PART NUMBER								

P Series 17" & 20" Glazer Schematic
 Model :97562 P Series 17" Floor Machine With Pad Holders (115V)

	Number	Description	Qty Req.
1	M1369GS+	14/3 STWA, 50' Gray Cord W/Strain Relief	1
2	SR36+	Strain Relief Washer	1
3	X8008N+	NUT LOCK 1/2" STEEL CONDUIT APPLETON	1
6	X8012+	Clamp, Collar, Handle	1
7	X8013+	Cord Hook, Plated	1
8	X8207+	Screw, 10-24 x 1/2"	1
9	X8012A+	Handle Tube Clamp Lever Assembly (excludes clamp collar)	1
10	X8016+	Knob, Plastic, Handle Release	1
11	X8807R+	HANDLE BRACE RIGHT M STYLE WITH RECTANGLE SLOT	1
12	X8807L+	HANDLE BRACE LEFT M STYLE WITH CIRCLE HOLE	1
13	X8809+	Pivot Shaft, 1/2" x 12-7/8"	1
14	X8019+	Axle Wheel	1
15	X8020+	WASHER COUNTERSUNK AXLE	1
16	X8024+	Wheel 5" x 1-1/4"	1
17	X8028+	Oval Cam Washer	1
18	X8035HD+	Motor Assembly	1
19	X8042A+	Motor Cover	1
20	X8050A+	Base Housing	1
21	X8040+	590 UF, 125V Start Capacitor for Doerr 1 HP 175 RPM	1
22	X8040+	590 UF, 125V Start Capacitor for Doerr 1 HP 175 RPM	1
23	X8022+	In-Line Cord	1
24	X8030I+	Bumper 38.25" Blu/Blk	1
25	X8151B+	Plug, Plastic, 7/16" Hole	1
26	X8258A+	Bumper, Blk, 1.13" OD x .75" H	1
27	X8258AS+	#8 x 1" PHPH Type "A"	1
29	X8821+	Screw, 8-32 x 3/4"	1
30	X8212+	1/4" Spring Lock Washer	1
31	X8212+	1/4" Spring Lock Washer	1
32	X8218+	Washer, Flat SAE 5/16"	1
33	X8219+	3/8" SAE Flat Washer	1
34	X8222+	SCREW 1/4-20 X 3/16 SOC SET FLAT POINT W/LOC-TITE	1
35	X8226+	1/4-20 x 1/ 1/4 Hex Head Cap	1
36	X8272+	Screw, 8-32 x 1/2", Truss/PH (2)	1
58	X8912+	Switch Box Cover	1
59	X8914+	Thumb Actuation Release	1
60	X8917+	Handle Trigger	1
61	X8916+	Trigger Tension Spring (2)	1
62	X8915+	Handle Trigger Thumb Actuatuin Spring	1
63	X8918+	Handle Roll Pin (2)	1
64	X8941+	1" Handle Grip (2)	1
65	X8207+	Screw, 10-24 x 1/2"	1
66	X8923+	Insulation Sheet	1
67	F5P+	Switch	1
68	X8911+	HANDLE ALL METAL FM_BURNISHR SHIP M8600-3+	1
69	7BG004	7/16" Diameter Grommet	1
70	X8222+	SCREW 1/4-20 X 3/16 SOC SET FLAT POINT W/LOC-TITE	1
71	PX7+	Switch for M172-3, M202-3	1
72	PX28+	Insulation boot for switch	1
73	X8265+	Bolt for axle	1
75	X8955+	Start Capacitor 380 UF 125V	1
76	X8953+	Start Capacitor 450 UF 125V	1
77	X8954+	Run Capacitor 50 UF 370V	1
78	X8046+	35 UF 370V Run Capacitor for Doerr 1-1/2 HP Doerr Model #R07559_G51400	1
79	X8056+	310 UF 125V Start Capacitor for Doerr 1-1/2 HP Doerr Model #R07559_G51400	1
80	7CY001	WASHER #10 INT TOOTH LOCK SS	1

P Series 17" & 20" Glazer Schematic, Model:97562 P Series 17" Floor Machine With Pad Holders (115V)

