

Operating Instructions (ENG)

MODEL: 115 V



1/2 HP MODELS ONLY

Read instructions before operating the machine.

MACHINE DATA LOG/OVERVIEW

MODEL _____

DATE OF PURCHASE _____

SERIAL NUMBER _____

SALES REPRESENTATIVE # _____

DEALER NAME _____

OPERATIONS GUIDE NUMBER _____

PUBLISHED _____

YOUR DEALER

Name: _____

Address: _____

Phone Number: _____

HOW TO USE THIS MANUAL

This manual contains the following sections:

- HOW TO USE THIS MANUAL
- SAFETY
- OPERATIONS
- MAINTENANCE
- PARTS LIST

The HOW TO USE THIS MANUAL section will tell you how to find important information for ordering correct repair parts.

Parts may be ordered from authorized dealers. When placing an order for parts, the machine model and machine serial number are important. Refer to the MACHINE DATA box which is filled out during the installation of your machine. The MACHINE DATA box is located on the inside of the front cover of this manual.

MODEL _____
DATE OF PURCHASE _____
SERIAL NUMBER _____
SALES REPRESENTATIVE # _____
DEALER NAME _____
OPERATIONS GUIDE NUMBER _____
PUBLISHED _____

The model and serial number of your machine is on the back of the machine.

The SAFETY section contains important information regarding hazard or unsafe practices of the machine. Levels of hazards is identified that could result in product or personal injury, or severe injury resulting in death.

The OPERATIONS section is to familiarize the operator with the operation and function of the machine.

The MAINTENANCE section contains preventive maintenance to keep the machine and its components in good working condition. They are listed in this general order:

- Power cord/switch

The PARTS LIST section contains assembled parts illustrations and corresponding parts list. The parts lists include a number of columns of information:

- **REF** – column refers to the reference number on the parts illustration.
- **PART NO.** – column lists the part number for the part.
- **QTY** – column lists the quantity of the part used in that area of the machine.
- **DESCRIPTION** – column is a brief description of the part.
- **SERIAL NO. FROM** – column indicates the first machine the part number is applicable to. When the machine design has changed, this column will indicate serial number of applicable machine. The main illustration shows the most current design of the machine. The boxed illustrations show older designs.
- **NOTES** – column for information not noted by the other columns.

NOTE: If a service or option kit is installed on your machine, be sure to keep the KIT INSTRUCTIONS which came with the kit. It contains replacement parts numbers needed for ordering future parts.

TABLE OF CONTENTS

Machine Data Log/Overview.....2

HOW TO USE THIS MANUAL

How to use this Manual.3
Table of Contents4

SAFETY

Important Safety Instructions5
Hazard Intensity Level.6
Grounding Instructions.....7

OPERATION

Set Up.....8
On/Off Procedure.....8

MAINTENANCE

Power Cord.....8
Dust in Motor Windings.....8
Lubricating Motor Sleeve Bearings.....8
Fan Removal.8
Power Cord/Capacitor..8
Motor Removal.8
Wiring Diagram...9

GROUP PARTS LIST

Body Assembly..... 10
Handle & Wheels..... 12

IMPORTANT SAFETY INSTRUCTIONS

When using an electrical appliance, basic precaution must always be followed, including the following:

READ ALL INSTRUCTIONS BEFORE USING THIS MACHINE.



WARNING:

To reduce the risk of fire, electric shock, or injury:

Use only indoors. Do not use outdoors or expose to rain.

Use only as described in this manual. Use only manufacturer's recommended components and attachments.

If the machine is **not working properly**, has been dropped, damaged, left outdoors, or dropped into water, return it to an authorized service center.

Do not operate the machine with any openings blocked. Keep openings free of debris that may reduce airflow.

Machine can cause a fire when operating near flammable vapors or materials. Do not operate this machine near flammable fluids, dust or vapors.

This machine is suitable for commercial use, for example in hotels, schools, hospitals, factories, shops and offices for more than normal housekeeping purposes.

Maintenance and repairs **must be done** by qualified personnel.

During operation, attention shall be paid to other persons, especially children.

When leaving unattended, secure against unintentional movement.

The machine shall only be operated by instructed and authorized persons.

When leaving unattended, switch off or lock the main power switch to prevent unauthorized use.

Do not handle the plug or machine with wet hands.

Do not unplug machine by pulling on cord. To unplug, grasp the plug, not the cord.

Do not use with damaged cord or plug. Follow all instructions in this manual concerning grounding the machine.

Do not pull or carry by cord, use cord as a handle, close a door on cord, or pull cord around sharp edges or corners.

Do not pull/run machine over cord. **Keep** cord away from heated surfaces.

Connect to a **properly** grounded outlet. See Grounding Instructions.

Use only on GFCI protected receptacles.

Do not use this fan with any solid-state speed control device.

SAVE THESE INSTRUCTIONS

HAZARD INTENSITY LEVEL

The following symbols are used throughout this guide as indicated in their descriptions:

HAZARD INTENSITY LEVEL

There are three levels of hazard intensity identified by signal words -**WARNING** and **CAUTION** and **FOR SAFETY**. The level of hazard intensity is determined by the following definitions:

⚠ WARNING:

WARNING - Hazards or unsafe practices which COULD result in severe personal injury or death.

⚠ CAUTION:

CAUTION - Hazards or unsafe practices which could result in minor personal injury or product or property damage.

FOR SAFETY: To Identify actions which must be followed for safe operation of equipment.

Report machine damage or faulty operation immediately. Do not use the machine if it is not in proper operating condition. Following is information that signals some potentially dangerous conditions to the operator or the equipment. Read this information carefully. Know when these conditions can exist. Locate all safety devices on the machine. Please take the necessary steps to train the machine operating personnel.

FOR SAFETY:

DO NOT OPERATE MACHINE:

Unless Trained and Authorized.

Unless Operation Guide is Read and understood.

In Flammable or Explosive areas.

In areas with possible falling objects.

WHEN SERVICING MACHINE:

Avoid moving parts. Do not wear loose clothing; jackets, shirts, or sleeves when working on the machine. Use Windsor approved replacement parts.

115V GROUNDING INSTRUCTIONS

THIS PRODUCT IS FOR COMMERCIAL USE ONLY.

ELECTRICAL:

In the USA this machine operates on a standard 15 amp 115V, 60 hz, A.C. power circuit . The amp, hertz, and voltage are listed on the data label found on each machine. Using voltages above or below those indicated on the data label will cause serious damage to the motors.

EXTENSION CORDS:

If an extension cord is used, the wire size must be at least one size larger than the power cord on the machine, and must be limited to 50 feet (15.5m) in length.

GROUNDING INSTRUCTIONS:

This appliance must be grounded. If it should malfunction or break down, grounding provides a path of least resistance for electric current to reduce the risk of electric shock. This appliance is equipped with a cord having an equipment-grounding conductor and grounding plug. The plug must be inserted into an appropriate outlet that is properly installed and grounded in accordance with all local codes and ordinances.

This appliance is for use on a nominal 120-volt circuit, and has a grounded plug that looks like the plug in "Fig. A". A temporary adaptor that looks like the adaptor in "Fig. C" may be used to connect this plug to a 2-pole receptacle as shown in "Fig. B", if a properly grounded outlet is not available. The temporary adaptor should be used only until a properly grounded outlet (Fig. A) can be installed by a qualified electrician. The green colored rigid ear, lug, or the like extending from the adaptor must be connected to a permanent ground such as a properly grounded outlet box cover. Whenever the adaptor is used, it must be held in place by a metal screw.

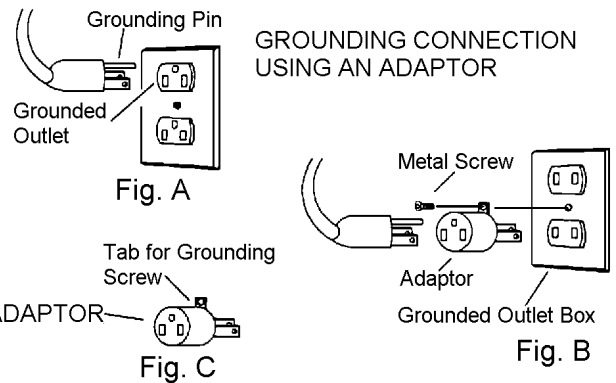

Note: Adaptors are not allowed in Canada.

⚠ WARNING:

Improper connection of the equipment-grounding conductor can result in a risk of electric shock. Check with a qualified electrician or service person if you are in doubt as to whether the outlet is properly grounded. Do not modify the plug provided with the appliance - if it will not fit the outlet, have a proper outlet installed by a qualified electrician. Use only GFCI protected receptacles.

OPERATION & MAINTENANCE

OPERATION

1. Open the doors or windows if possible to aid in ventilation.
2. Ensure that the unit is turned off, plug the power cord into the outlet.
3. Turn the switch to the desired speed.
4. Turn the unit off before un-plugging the power cord from the outlet.

MAINTENANCE

1. Frequently inspect power cord for frayed or damaged insulation.



Remove machine power cord from electrical source before making any repairs or adjustments to machine.

POWER CORD/SWITCH

Power cord and switch can be serviced.

1. Remove the 4 screws holding switch down.
2. To replace switch unplug wires and replace switch. See wiring diagram.
3. To replace power cord see step 1.
4. Unplug wires, loosen strain relief and remove cord.
5. Replace power cord. See wiring diagram.

CAUTION: When reinstalling motor and fan, make sure the wires are positioned and secured so they will not touch fan during rotation.

CAUTION: When reinstalling electrical parts, refer to wiring diagram for correct connections

WIRING DIAGRAM

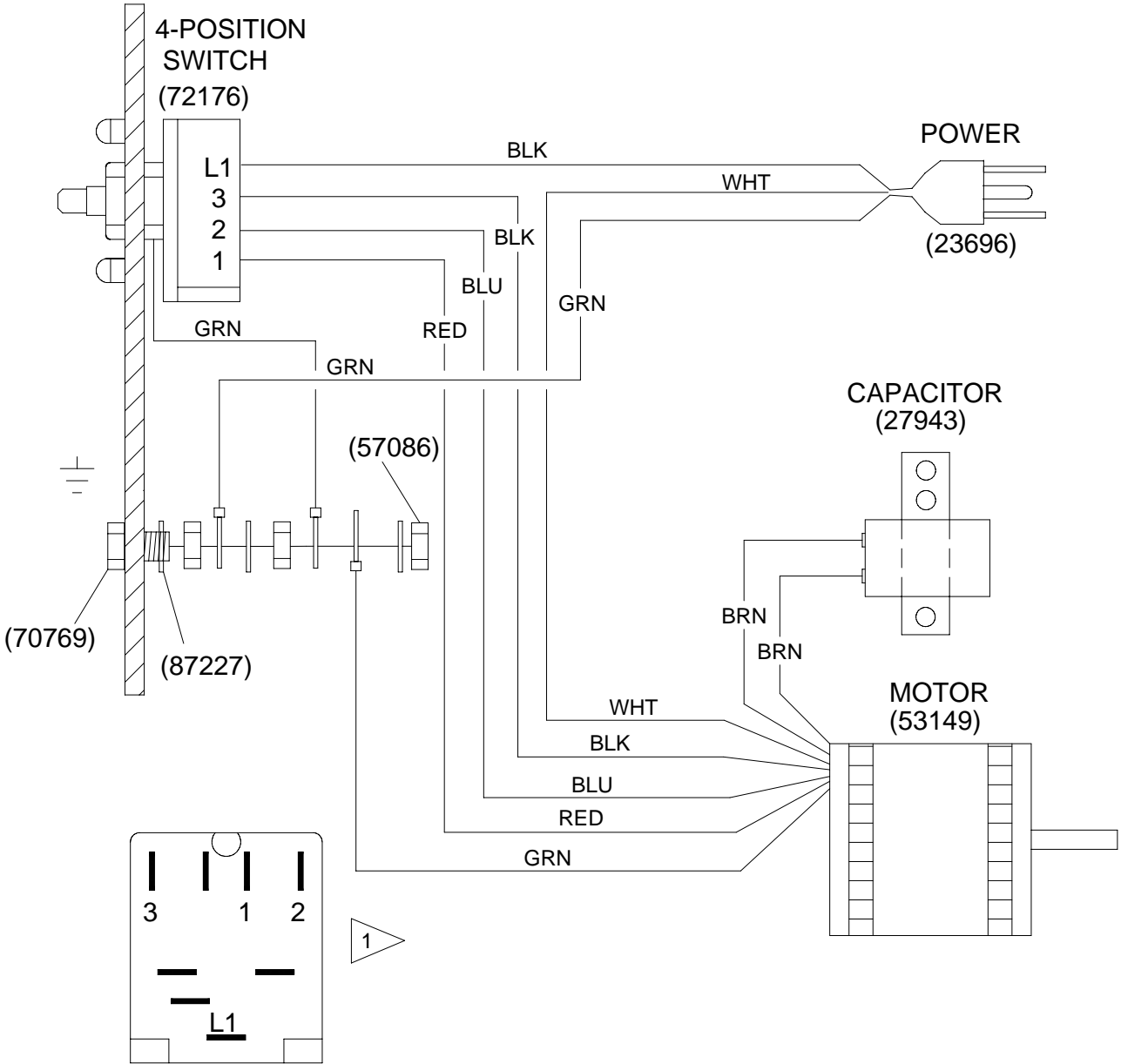

REAR VIEW OF SWITCH

1 COVER UNUSED TERMINALS WITH FEMALE COUPLER (76029L).

AIR BLOWER BODY ASSEMBLY

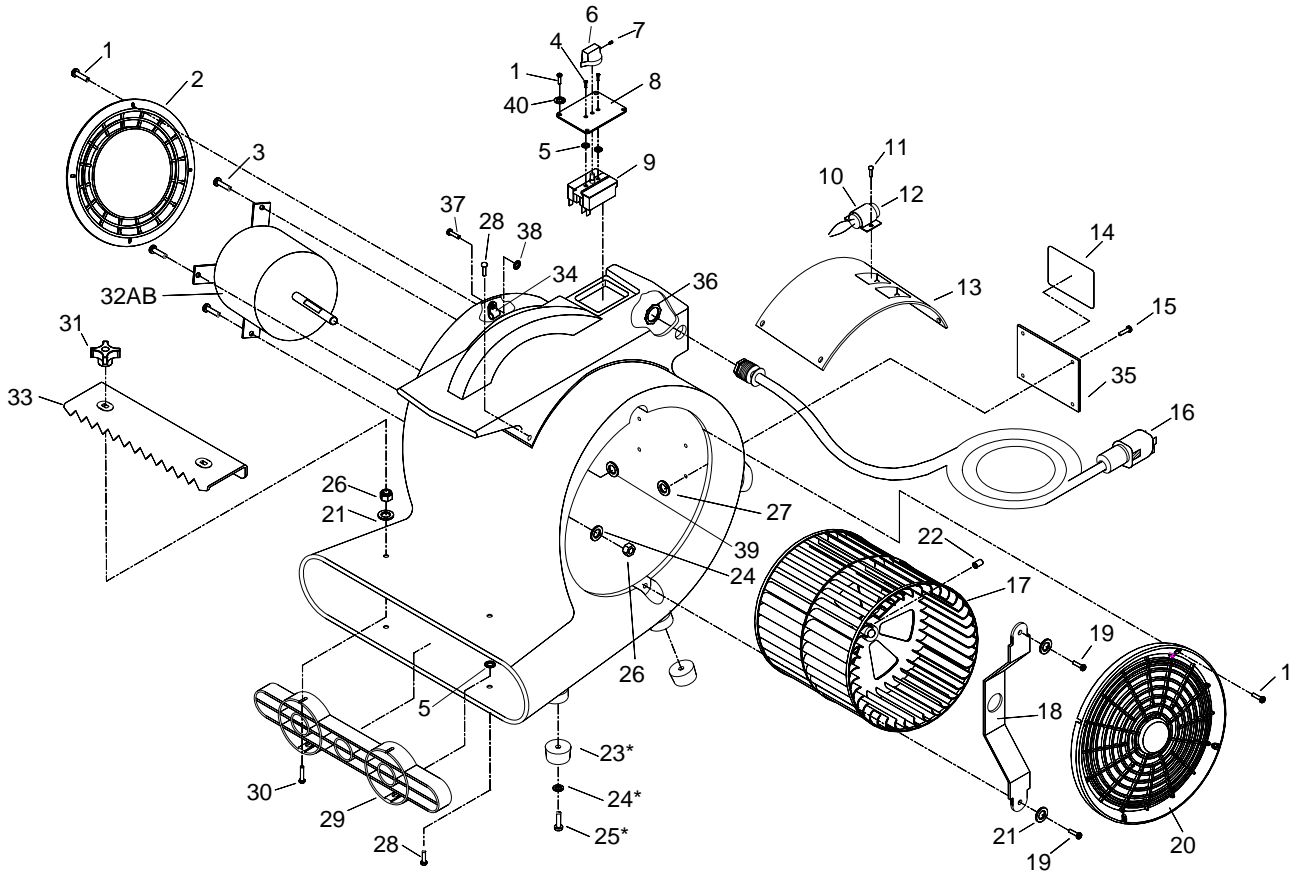

AIR BLOWER BODY ASSEMBLY

REF	PART NO.	QTY	DESCRIPTION	SERIAL NO.	NOTES:
1	70765	12	SCR, M4 X 15MM PH SHEET METAL		
2	36210	1	GUARD, 9" AB		
3	70768	2	SCR, M6-1 X 16MM FHMS BLK		
4	70246	2	SCR, 8-32 X 1/4 PPHMS BLK		
5	87255	7	WASHER, M4 RIVET BACKUP		
6	48084	1	KNOB, SWITCH AB		
7	70771	1	SET SCR, M3 X 8MM X .5		
8	62928	1	PLATE, SWITCH AB		
9	72176	1	SWITCH, 3 SPEED ROTARY		
10	140474	1	CLAMP, CAPACITOR		
11	67481	2	RIVET, M4 X 14MM		
12	27943	1	CAPACITOR		
13	62936	1	PLATE, INNER AB		
14	50344	1	LABEL, WARNING		
15	67483	4	RIVET, M3 X 12MM		
16	23696	1	CORD, 14X3 SJT, AB		
17	34389	1	FAN, SQUIRREL CAGE		
18	140467	1	BRKT, MOTOR SHAFT AB		
19	70764	2	SCR, M6-1 X 15 PPHMS PLTD BLK		
20	36211	1	GUARD, 10" AB		
21	87211	4	WASHER, M6 FLAT BLK		
22	70770	1	SET SCR, M8 X 8MM CUP POINT		
23	66352	4	FOOT BLOWER		*FOR MODEL W/O HANDLE
24	87218	8	WASHER, M6 PLAT		*FOR MODEL W/O HANDLE
25	70767	4	SCR, M6-1 X 19MM PPHMS		*FOR MODEL W/O HANDLE
26	57220	6	NUT, M6X1 HEX NYLOCK PLTD		
27	87226	4	WASHER, M3 RIVET BACKUP		
28	67481	6	RIVET, M4 X 14MM		
29	36212	1	GUARD, FRONT AB		
30	70763	2	SCR, M6-1 X 40MM		
31	48085	2	KNOB, CARPET CLAMP		
32A	53149	1	MOTOR, 115V 3SPD 1/2 HP		
32B	53803	1	MOTOR, 115V 3SPD 1 HP		
33	20100	1	CLAMP, CARPET		
34	20005	1	CLAMP, 5/16 NYLON		
35	62214	1	PLATE, WARNING LABEL		
36	87231	1	WASHER, M18 STAR		
37	87484	1	RIVET, M5 X 20		
38	87230	1	WASHER, M5 RIVET BACKUP		
39	87225	4	WASHER, M4 RIVET BACKUP		
40	87239	4	WASHER, M4 INT STAR BLK ZNC PLT		

AIR BLOWER HANDLE

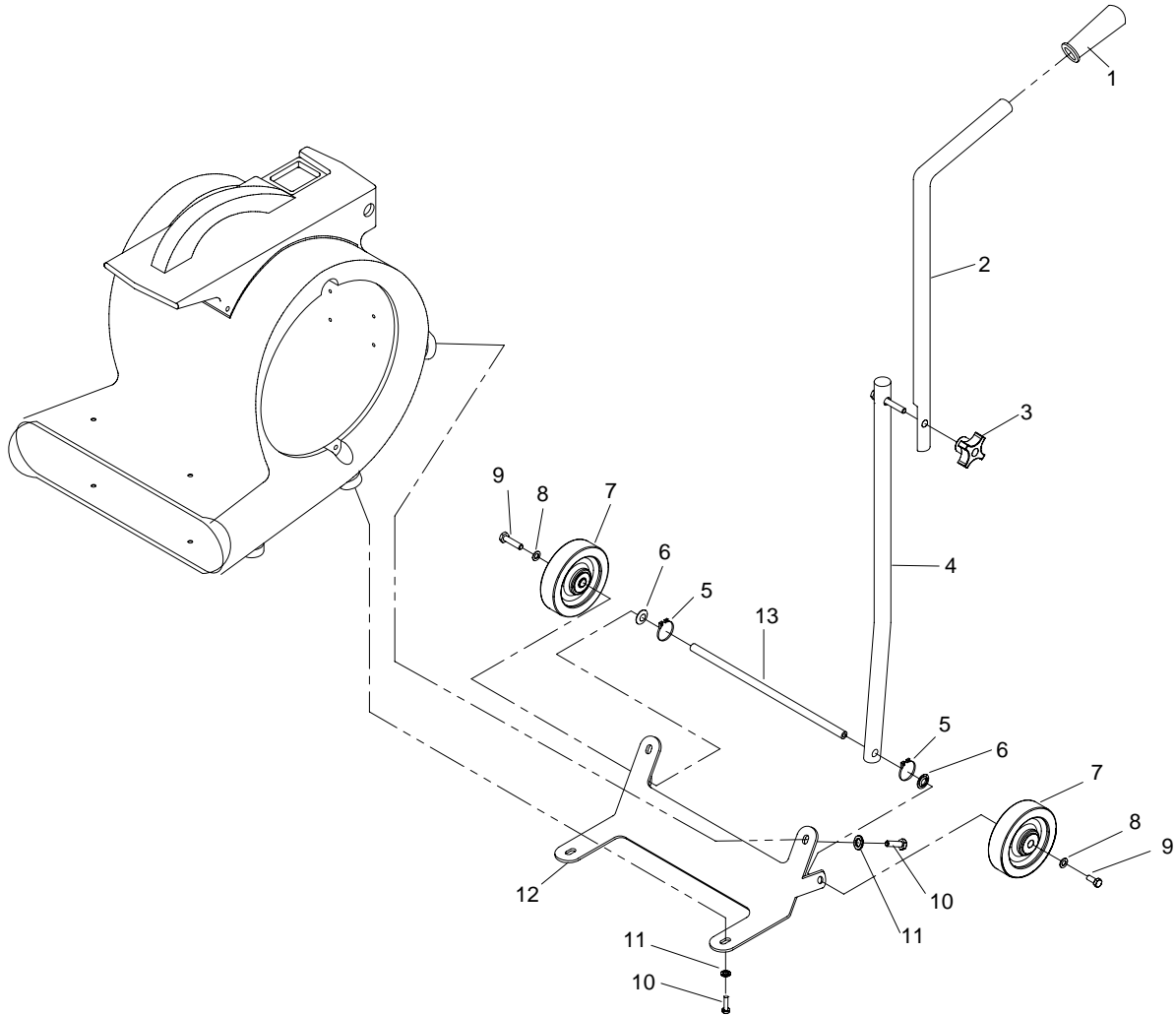

AIR BLOWER HANDLE

REF	PART NO.	QTY	DESCRIPTION	SERIAL NO. FROM	NOTES:
1	36196	1	GRIP, POLISHER HANDLE		
2	78486	1	TUBE, HANDLE UPPER		
3	48087	1	KNOB, HANDLE LOCK		
4	78485	1	TUBE, HANDLE LOWER		
5	67469	2	RING, 13MM EXTERNAL SNAP		
6	57276	2	NUT, PUSH FLAT RD .51ID		
7	89206	2	WHEEL, 5D X 1.25 X 13MM ID GRY		
8	87054	2	WASHER, M8 FLAT DIN125A PLT		
9	70262	2	SCR, M8 X 20 HHMS PLTD		
10	70767	2	SCR, M6 X 1 HEX NYLOCK PLTD		
11	87233	2	WASHER, 20MM OD		
12	140495	1	BRACKET, WHEEL, BLOWER		
13	03118	1	AXLE, WHEEL, BLOWER		